

CA900 Sulfide Ion Analyzer

The ECD **6** Point Advantage



ELECTRO-CHEMICAL DEVICES

- 1 Compact all in one measurement system**, conditions the sample, measures the sulfide, neutralizes the sample, measures the pH, drains and rinses the cell.
- 2 ISE based Sulfide Ion Measurement** provides a wide measurement range, 20 ppb to 500 ppm using economical, easily replaceable electrode cartridges
- 3 pH adjusted and compensated measurement** the sample is optimized for the sulfide ion that only exists at high pH values
- 4 Sample neutralized after measurement** the highly caustic sample pH is reduced to a safe level near pH 8
- 5 Reliable Design – Touchscreen Interface** User-friendly menus and configurations, two separate compartments (Electronic and Hydraulics Liquids)
- 6 Cost effective Low reagent consumption** Less than 2 gallons per month of 10 % KOH and an equivalent amount of HCl at 10 samples per hour or 5 months at 2 samples per hour.



Description

The ECD CA900 Sulfide Analyzer is an all in one analyzer for the continuous measurement of sulfide ions in aqueous media. Sulfide is present in well water, municipal waste water and waste waters from refineries, tanneries, chemical plants and paper and pulp facilities.

Hydrogen sulfide (H_2S) is a gas that dissolves in water and gives it that “rotten egg” odor. H_2S exists in acidic water as a dissolved gas, at pH values above pH 7 bisulfide ions (HS^-) are the predominate form and at very high pH values, $> pH13$, sulfide ions (S^{2-}) predominate.

The ECD CA900 uses a sulfide ion selective electrode (ISE) to measure the total amount of sulfide present in the sample. The measurement must be made at high pH levels where S^{2-} exists. Potassium hydroxide (KOH) is added to raise the pH of the sample to around pH 13 and a pH electrode measures the actual pH. Sulfide and bisulfide exist in a pH dependent equilibrium with the ratio of each dependent on the pH. The sulfide ISE measures the sulfide present in the sample and the pH measurement infers what percentage of the total sulfide was measured. The analyzer calculates and displays the Total sulfide present.

The highly caustic sample is then neutralized with HCl and the pH is measured and displayed to verify the neutralization. The neutralization of KOH with HCl produces potassium chloride salt (KCl) and water. The neutralized sample can be disposed of as waste or returned to the water supply.

The ECD CA900 is a sequential sampling analyzer. It runs the following analysis cycle; fill the measurement cell with sample and drain, fill and drain, fill, add caustic, mix, measure S^{2-} , adjust 4-20 mA signal, add acid, mix, measure pH, adjust 4-20 mA signal, drain the flow cell and repeat the cycle. Each cycle uses about 1 ml of caustic and 1 ml of acid. The analyzer is set to run 6 minute analysis cycles but can easily be programmed to run 12 minute or 30 minute cycles. Running continuously at 10 cycles per hour, the CA900 uses 7.2 liters of each reagent per month, at 5 cycles per hour, 3.6 liters per month and at 2 cycles per hour less than 1.5 liters per month.

The ECD CA900 is easy to start up and maintain. First connect the Sample feed line, reagent lines and Drain line to the analyzer. Mount the sulfide and pH sensors in the flow cell. Next connect the two outputs, S^{2-} and pH and supply power, a switched 110/220 VAC line. Prime the peristaltic pumps and start the measurement cycle. The touch screen display and 4-20 mA outputs will indicate the total sulfide and the neutralized pH value. A digital display indicates the Sulfide measurement and the 4-20 mA output values are captured in the measurement cycle and displayed until the next measurement cycle.



ELECTRO-CHEMICAL DEVICES CA900 Sulfide Ion Analyzer

Specifications

Principle of Operation

Sequential sampling, Sulfide Ion Selective Electrode, pH compensated measurement, sample neutralization

Measurement Range

0.02 - 500 mg/l (0.02 - 500 ppm)

Temperature Range

-5° - 50°C (20° - 120°F) Measuring

Cycle Response Time

6, 12 or 30 minutes, user selectable

Accuracy

± 20 ppb or 5 % of reading, whichever is greater

Repeatability

± 2 % of reading

Operating Conditions

Temperature: 10° - 50°C

Humidity: 5 to 95% noncondensing humidity

Sample Requirements

Pressure: Sample should be drawn from atmospheric pressure

Flow: greater than 100 ml/minute

Temperature: 10° - 50°C

Reagents

16% KOH, Potassium Hydroxide

7.5 % HCl, Hydrochloric Acid, (Muriatic Acid)

Reagent Consumption:

6 minute cycle time: 7.2 liters/ month, (1.9 gallons) each

12 minute cycle time: 3.6 liters/month, (0.95 gallons) each

30 minute cycle time: 1.5 liters/month., (0.4 gallons) each

Hydraulic Connections

Sample Inlet: 1/8" ID tubing barb fitting

Drain Outlet: 1/4" ID tubing barb Fitting

Power Requirement

100/240 Vac, 50/60 Hz, switch selectable

Data Logging

Configurable Data Recording, Storage, and Output

Analog output

Four 4-20 mA outputs

Alarms

4 configurable relays SPDT 15A 250VAC

Connections

2 x 4-20 mA, Line Neutral and Ground for Power

All connections are to a terminal strip, Access through IP65 1/2" cable glands

Enclosure

Gray hot-molded fiberglass reinforced polyester transparent polycarbonate cover with non-metallic hinges. NEMA 4X, Protection degree IP66-11

Mounting

Wall mounting or with optional bench support

Operating temperature

5-50°C

Cabinet

Non Metallic

Dimensions

17" L x 32" H x 9" D (43cm x 81cm x 23cm)

Weight

Approx. 30 lbs (14 kg)

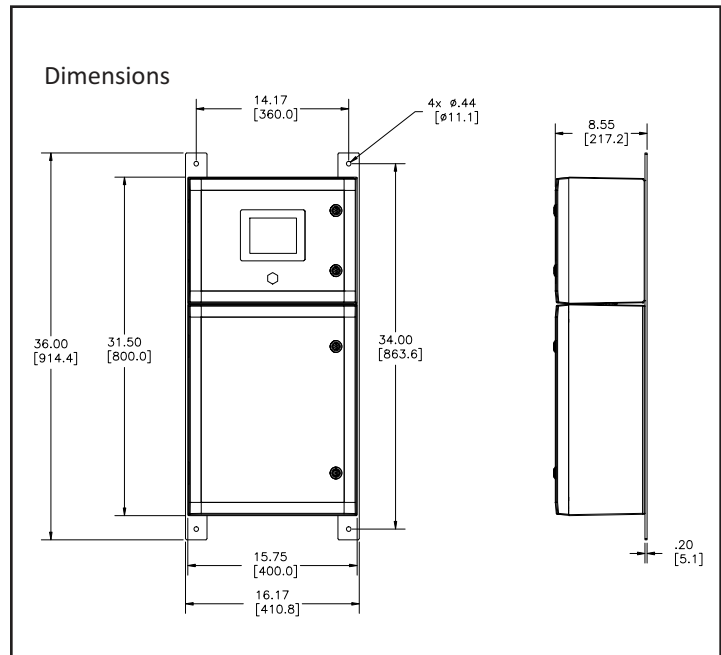

Order Information

Part #	Description
1200140-1	CA900 Sulfide Analyzer, Complete, No Reagents

Accessories and spare parts

2000027	Tubing Kit, replacement kit for all interior tubing, recommended every 3 months
2010040-1	Reagent Kit, 2.5 gallons each, 16 % KOH and 7.5 % HCl
2005122.VIT	Sulfide Ion Electrode
2005138.VIT	pH electrode for high pH
1000270-1	Fast loop reservoir (atmospheric sample conditioner, constant head overflow)

Specifications subject to change without notice

Represented by:

Electro-Chemical Devices

1500 North Kellogg Dr.
Anaheim, California, USA 92807

Phone: +1-714-695-0051

+1-800-729-1333

Fax: +1-714-695-0057

email: sales@ecdi.com

web: www.ecdi.com

