



Instruction Manual

UV80 Sensor

With Automated Cleaning Wiper



This page intentionally left blank

PREFACE

Purchasing products from Electro-Chemical Devices, Inc. provides you with the finest liquid analytical instrumentation available. If this is your first purchase from ECD, please read the entire manual before installing and commissioning your new equipment.

Manuals are accessible on the ECD website at <https://ecdi.com/product-literature/manuals/>.

If there are any questions concerning this equipment, please contact your local ECD representative, or the factory directly at:

Electro-Chemical Devices, Inc.

1500 N Kellogg Dr
Anaheim, CA 92807-1902 USA





Telephone: +1-714-695-0051

FAX: +1-714-695-0057

Website: www.ecdi.com

Email: sales@ecdi.com

SYMBOLS USED IN MANUAL

	This symbol is used to designate important information, warnings and cautions. Failure to follow this information could lead to harm to the instrument or user.
	No operator serviceable parts, service by authorized service personnel only.
	This symbol is used to designate a WARNING "Risk of Electrical Shock"
	Disconnect supply before servicing
	Equipment protected throughout by double insulation.

	Read the complete manual before installing or using the equipment.
---	--

Contents of this manual are believed to be correct at the time of printing and are subject to change without notice. ECD is not responsible for damage to the instrument, poor performance of the instrument or losses resulting from such, if the problems are caused by:

- Incorrect operation by the user.
- Use of the instrument in incorrect applications.
- Use of the instrument in an inappropriate environment or incorrect utility program (power supply).
- Repair or modification of the related instrument by anyone not authorized by ECD.
- There are no operator accessible parts. Service and maintenance to be done by authorized personnel only.
- If the equipment is used in a manner not specified by the manufacturer, the protection provided by the equipment may be impaired.

© 2022 Electro-Chemical Devices, Inc. All rights reserved. No part of this manual may be used or reproduced in any form or by any means, or stored in a database or retrieval system without prior written permission from Electro-Chemical Devices, Inc. Making copies of any part of this manual for any purpose other than personal use

TABLE OF CONTENTS

Preface.....	2
Symbols Used in Manual	3
Return Goods Policy	6
Unpacking the Instrument	7
1.0 Introduction.....	8
2.0 Installation.....	8
2.1 UV80 Installation.....	8
2.1.1 Standpipe Installation.....	8
2.1.2 Flow Cell Installation.....	10
2.2 T80 Mounting.....	11
2.3 T80 Wiring.....	13
2.2.1 Wiring, Power	13
2.2.2 Wiring, Sensor.....	14
2.2.3 Wiring, 4-20 mA Outputs.....	14
2.2.4 Wiring, Contact Relay Outputs	15
2.2.5 Wiring, Serial Output MODBUS RTU.....	15
3.0 Operation	15
4.0 Calibration	15
4.1 Auto Cal.....	16
4.2 Standardize	16
4.3 Manual Cal	16
5.0 Maintenance	17
6.0 Specifications.....	18
6.1 UV80 / Organic load Sensor	18
6.2 T80 Transmitter Specifications.....	19
7.0 Troubleshooting	20
8.0 Parts and Accessories (T80).....	21
8.1 Front Panel Control Board Exploded, with Relays	21
8.2 Transmitter Case, back with Cable Glands.....	22
8.3 Replacement Parts	23
8.4 Accessories.....	23

Terms and Conditions of Sale

1. **ACCEPTANCE.** If this writing differs in any way from the terms and conditions of Buyer's order or if this writing is construed as an acceptance or as a confirmation acting as an acceptance, then Seller's acceptance is **EXPRESSLY MADE CONDITIONAL ON BUYER'S ASSENT TO ANY TERMS AND CONDITIONS CONTAINED HEREIN THAT ARE DIFFERENT FROM OR ADDITIONAL TO THOSE CONTAINED IN BUYER'S WRITING.** Further, this writing shall be deemed notice of objection to such terms and conditions of Buyer. If this writing is construed as the offer, acceptance hereof is **EXPRESSLY LIMITED TO THE TERMS AND CONDITIONS CONTAINED HEREIN.** In any event, Buyer's acceptance of the goods shall manifest Buyer's assent to Seller's terms and conditions. No addition to or modification of these terms will be effective, unless set forth in writing and agreed to by Seller.
2. **WARRANTIES AND REMEDIES**
 - a. **Warranty.** Seller warrants to Buyer that it holds and will pass marketable title to the goods sold hereunder. Seller warrants to Buyer that the items and components manufactured by Seller will be free from defects in material and workmanship (subject, however, to tolerances and variances permitted by the trade hereunder) for a period one (1) year for non-consumable products. Consumable electrodes and sensors have a conditional warranty based shelf life and process conditions and is determined by Seller.
 - b. **Exclusion and Conditions.** Seller's obligations with respect to the express warranties and remedies contained herein are conditioned on the following: (i) Buyer's return of the non-conforming goods, if authorized by Seller; (ii) Buyer shall not assign its rights under these express warranties and any attempted assignment shall render such warranties, but not any disclaimers or limitations, void and the goods sold shall be sold **AS IS**; and (iii) all products shall be carefully inspected for damage by Buyer upon receipt, be properly calibrated for Buyer's particular use, and be used, repaired, and maintained by Buyer in accordance with the instructions set forth in Seller's product literature. Repair and maintenance by non-qualified personnel, product subjected to misuse or negligence, and/or damaged during shipment will invalidate the warranty, as will the use of non-approved consumables or spare parts. As with any other sophisticated product, it is essential, and a condition of Seller's warranty, that all personnel using the product be fully acquainted with its use, capabilities and limitations as set forth in the applicable product literature.
3. **DISCLAIMER OF IMPLIED WARRANTIES.** Seller gives no warranties except those expressly contained herein. Seller **disclaims** all other warranties implied by law usage of the trade, course of dealing or course of performance including, but not limited to, **the implied warranties of MERCHANTABILITY and fitness for a particular purpose.**
4. **LIMITATIONS OF LIABILITY.** The following limitations of Seller's liability are acknowledged by the parties to be fair and reasonable and shall apply to any act or omission hereunder, and to any breach of this contract of which these terms and conditions form a part:
 - a. **Disclaimer of Damage.** In no event shall Seller be liable for special, indirect, consequential or incidental damages whether arising under contract, warranty, tort, strict liability or any other theory of liability. Such damages include but are not limited to loss of profits, loss of use of goods, damage to property, and claims of third parties.
 - b. **Suitability.** Buyer acknowledges that it alone has determined the intended purpose and suitability of the goods sold hereunder. It is expressly agreed by the parties that any technical or other advice given by the Seller with respect to the use of the goods or services is given without charge and at Buyer's risk; therefore Seller assumes no obligation or liability for the advice given or results obtained.
 - c. **Notice and Time of Claims.**
 - i. Buyer agrees to check and inspect all products against shipping papers and for damage or shortage upon receipt of goods at destination.
 - ii. Every claim for shortage, damage in transit, or other cause visible upon inspection shall be deemed waived by the Buyer, or the Buyer's customer in the case of resale, unless delivered in writing to Seller by Buyer thirty (30) days from the tender of delivery of the goods to Buyer, provided, however, that claims for shortage must be made within seven (7) days of receipt.
 - iii. The parties expressly waive the statute of limitations and agree that any legal proceeding for any breach of this contract shall be waived unless filed within one (1) year after the accrual of the cause of action thereof.
5. **FORCE MAJEURE.** Seller shall not be liable for any delay in delivery, or failure to deliver, due to any cause beyond the Seller's control including but not limited to fires, floods, or other forces of the elements; strikes, or other labor disputes; accidents to machinery; acts of sabotage; riots; precedence or priorities granted at the request or for the benefit, directly or indirectly of the federal or any state government or any subdivision or agency thereof; delay in transportation or lack of transportation facilities; restrictions imposed by federal, state or other governmental legislation or rules or regulations thereof. If Seller, in its sole discretion, determines that Seller's performance hereunder would result in a loss to Seller's on this sale as computed under Seller's normal accounting procedures because of causes beyond Seller's control, then the Seller may terminate this agreement in whole or in part without liability for any delay in the delivery of, or failure to deliver, the goods sold hereunder
6. **TAXES AND OTHER CHARGES.** The Buyer will pay, or reimburse Seller if it pays, any and all taxes or tariffs or any other similar charges imposed upon this contract, the goods covered hereby or the delivery or use or resale thereof.
7. **FREIGHT CHARGES.** If the sale hereunder is other than F.O.B. Seller's facility, this acknowledgement is based upon the freight charges now in effect. In the event of an increase or decrease in applicable freight charges before the goods are shipped, such charge in freight will be for the Buyer's account.
8. **PRICES AND DELIVERY.** Prices quoted herein are F.O.B. shipping point. Deliveries specified are only our best estimate and are subject to change. This quotation is based upon freight charges now in effect. Buyer will be invoiced at the freight charge prevailing at the date of shipment. Prices are firm for orders meeting Seller's normal shipping schedules. If shipments are held or postponed for any reason other than Seller's fault, and a price increase becomes effective during the period of such hold or postponement, the increase will apply to all shipments that are held or postponed thirty (30) days or more from the effective date of the increase.
9. **PAYMENTS.** If in the judgment of Seller the financial condition of Buyer at any time prior to shipment does not justify the terms of payment specified, Seller may cancel the order, withhold shipment, and/or require full or partial payment in advance. If payment is not made when due, Seller may suspend all future delivery or other performance with respect to Buyer without liability or penalty and, in addition to all other sums payable hereunder, Buyer shall pay to Seller (i) the reasonable costs and expenses incurred by Seller in connection with all actions taken to enforce collection or to preserve and protect Seller's rights hereunder, whether by legal proceedings or otherwise, including without limitation reasonable attorneys' fees, court costs and other expenses and (ii) interest on all amounts unpaid after 30 days charged at the monthly rate of 1-1/2% or the highest rate permitted by law, whichever is lower.
10. **CANCELLATION OR ALTERATION.** Buyer may not alter or cancel any order without Seller's written consent. For any order altered or cancelled with Seller's consent, Buyer must pay for all expenses and labor incurred up to the time of Seller's consent, plus a reasonable percentage for profit. Any order delayed or deferred by Buyer will be subject to price escalation for increased costs of production, and any other expenses caused by the delay. Material on such orders will be stored at Buyer's risk. Seller reserves the right to invoice Buyer and require payment before shipment of any delayed or deferred order.
11. **TITLE AND RISK OF LOSS.** Title and risk of loss shall pass to buyer at Anaheim, California, unless otherwise specified in the contract. If delivery is made by common carrier, risk of loss shall pass upon delivery to the carrier. Claims for loss or damage in transit must be made by Buyer to the carrier. Seller accepts no responsibility for loss or damage to product in transit.
12. **PATENT OR TRADEMARK INFRINGEMENT.** If the goods sold hereunder are to be prepared for manufacture according to Buyers specification, Buyer shall indemnify Seller against any claim or liability for patent, trademark, service mark or trade name infringement on account of preparation, manufacture and/or sale.
13. **NON-WAIVER.** If Government Contract Regulations require the addition, deletion, or modification of these terms and conditions upon prior notification to Seller and Seller's written acceptance thereof, such changes shall become a part of these terms and conditions. Seller shall not be bound by any Government Contract Regulations applicable to Buyer's contracts with the U.S. Government unless Buyer has expressly acknowledged, on the face of this document, the applicability of such Regulations to the transaction between Buyer and Seller contemplated herein. Absent such acknowledgement, Seller is making the assumption in issuing this document that no such Regulations apply.
14. **JURISDICTION.** All such disputes shall be resolved in a court of competent jurisdiction in Orange County, California. Buyer hereby consents to the jurisdiction of the State and Federal Courts sitting in Orange County. Notwithstanding the above, should either party contest the jurisdiction of such courts, the other party may institute its suit in any court of competent jurisdiction.
15. **APPLICABLE LAW.** All questions arising hereunder or in connection with the quotations or any order submitted in connection therewith and/or the performance of the parties hereunder shall be interpreted and resolved in accordance with the laws of the state of California without regard to its conflict of law provisions and excluding the United Nations Convention on the International Sale of Goods.

RETURN GOODS POLICY

All requests for returned goods must be initiated through our Customer Service Department. Please call our phone number (714) 695-0051 with the specifics of your request. The following conditions must be satisfied for consideration of applicable credit for the return of products purchased from Electro-Chemical Devices:

- 1) The item is unused and in the original package.
- 2) The item was shipped directly from Electro-Chemical Devices.
- 3) The item has not been damaged in shipment to Electro-Chemical Devices.
- 4) Items containing date-sensitive parts such as electrodes, must be returned within 1 month of the invoiced date.
- 5) Items without date-sensitive parts must be returned within 3 months of the invoiced date.

A Return Merchandize Authorization Number must be obtained from Customer Service and be provided on all paperwork and packaging. To obtain a Return Merchandize Authorization Number, please provide the reason for return, the date of purchase, your original purchase order number, and either our order number or our invoice number. The issuance of a Return Merchandize Authorization Number is a verbal approval for return only and does not guarantee credit or allowance. Returned goods must be received within 30 days of the issuance date of the Return Merchandize Authorization Number or it will become null and void.

Necessary physical and mechanical inspection is completed upon receipt of the item. Applicable credit or equivalent allowance is determined after inspection of the returned item. If all of the above conditions are met, and the item has been approved to return to our stock, a restocking charge of 25% of the purchase price is deducted from the applicable credit.

UNPACKING THE INSTRUMENT

Your Electro-Chemical Devices instrument has been carefully packaged to protect it from damage during shipment and dry storage. Upon receipt please follow the procedure outlined below.

1. Before unpacking, inspect the condition of the shipping container to verify proper handling by the carrier. If damage is noted, save the shipping container as proof of mishandling for the carrier.
2. Check the contents of the shipping container with the items and quantities shown on the packing list. Immediately report any discrepancies to ECD.
3. Save the original packing material until you are satisfied with the contents. In the event the product(s) must be returned to ECD, the packing material will allow you to properly ship it to ECD.
4. Familiarize yourself with the instrument before installation, and follow proper installation and wiring procedures.



WARNING Electrical installation must be in accordance with the National Electrical Code (ANSI/NFPA-70), Canadian Electrical Code and/or any other applicable national or local codes.

INSTALLATION AND WIRING

Failure to follow the proper instructions may cause damage to this instrument and warranty invalidation. Use only qualified personnel to install, operate and maintain the product.

The Model UV80 Sensor should only be used with equipment that meets the relevant IEC, American or Canadian standards. ECD accepts no responsibility for the misuse of this unit.

1.0 INTRODUCTION

The Model UV80 is a sensor for water monitoring. The sensor works with the principle of UV absorption photometry and can be used to detect organic material. Some of these organic compounds react with chlorine and chloramines to produce harmful trihalomethanes and haloacetic acids. In many cases the UV absorption measurements can be correlated with sum parameters like chemical oxygen demand, biochemical oxygen demand, and total organic carbon (COD, BOD, and TOC). The design is compact, robust, and can operate to a depth of 60 meters. The UV80 incorporates an automated mechanical wiper.

2.0 INSTALLATION

2.1 UV80 INSTALLATION

UV80 Installation can be accomplished with a 1" stand pipe for immersion service or flow cell for an in line flow through application or flow cell. Refer to the following drawing configurations.

2.1.1 STANDPIPE INSTALLATION

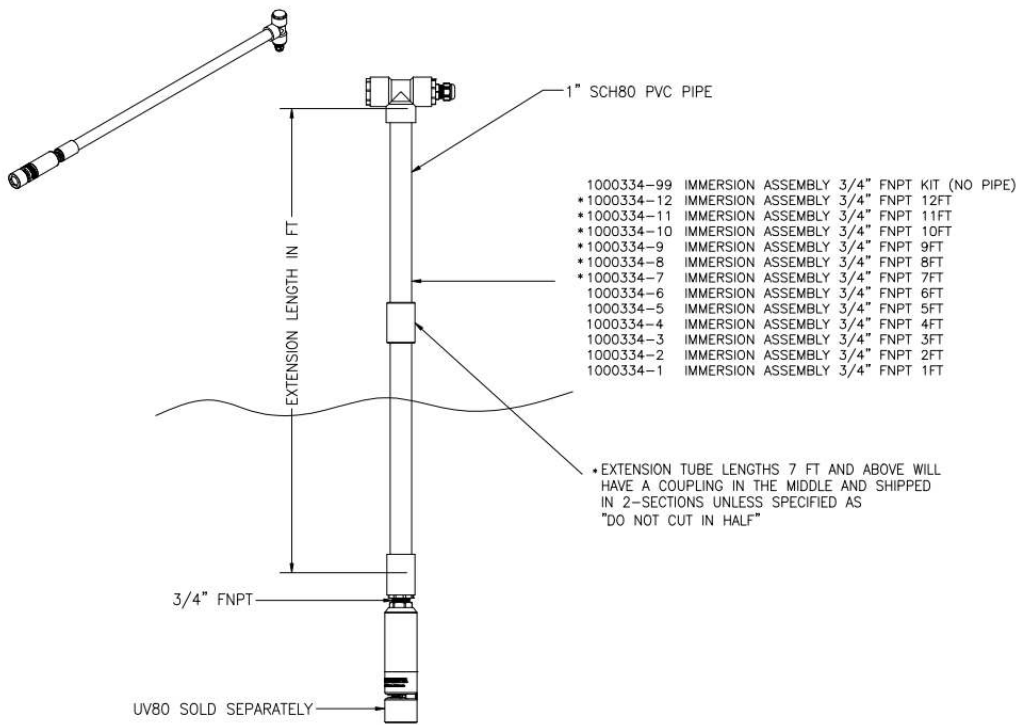

Drawing 4045691 rev A

Figure 1: Standpipe Installation

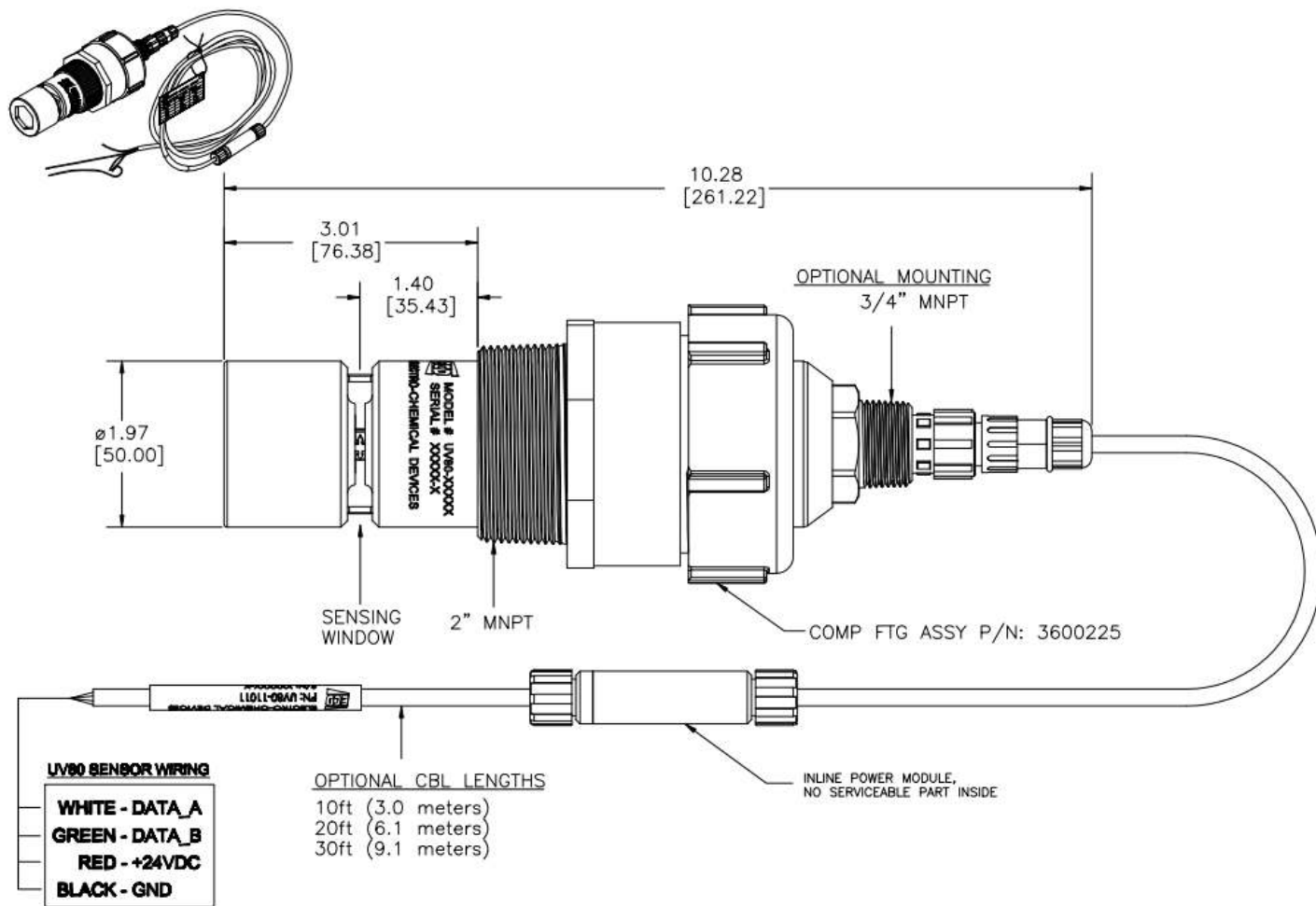

Drawing 4045677 rev A

Figure 2: Gland Fitting

2.1.2 FLOW CELL INSTALLATION

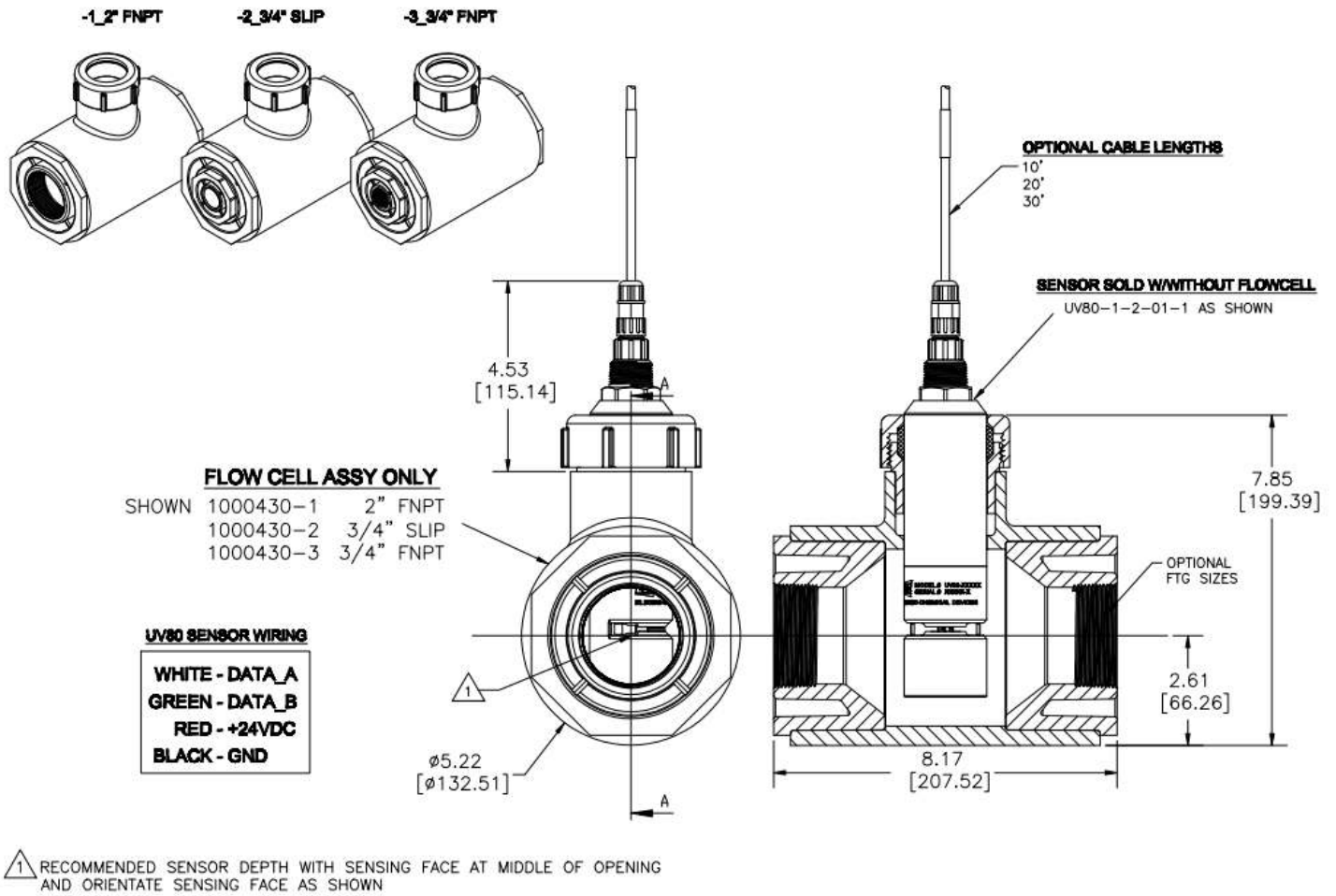

Drawing 4045675 rev A

Figure 3: Flow Cell Installation

2.2 T80 MOUNTING

Mount the T80 in a location where there is easy access to the analyzer and sensors. Install the system in an area where vibrations, electromagnetic and radio frequency interference are minimized or absent. Do not mount in direct sunlight or areas of extreme heat (temperature > 120°F (49°C)). The IP65 T80 is suitable for outdoor use but is best to mount it with a protective cover or sunshield to prevent discoloring over the years.

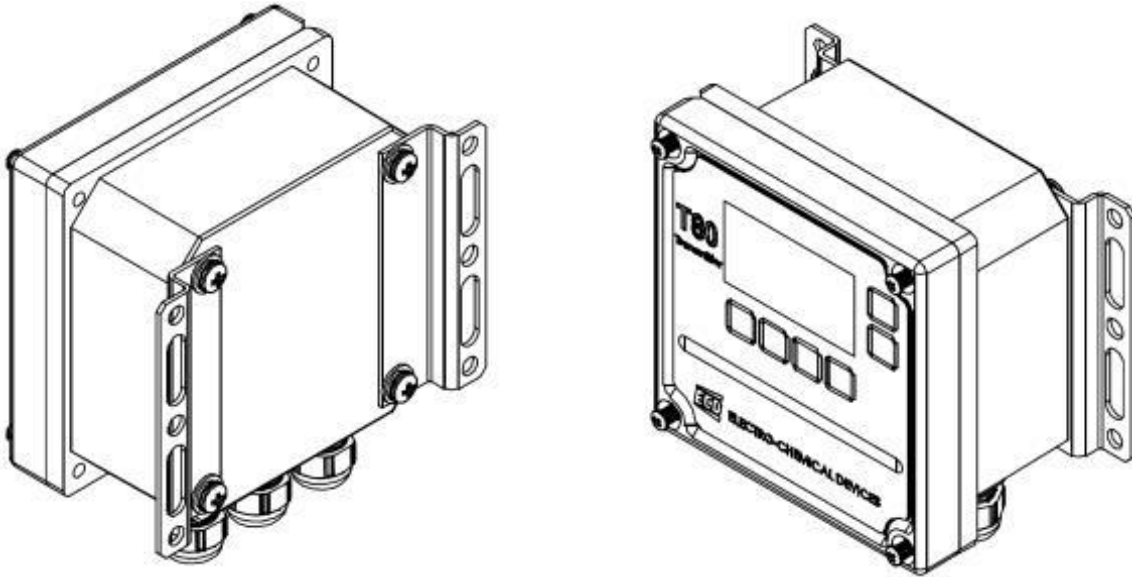

Universal Mounting Brackets

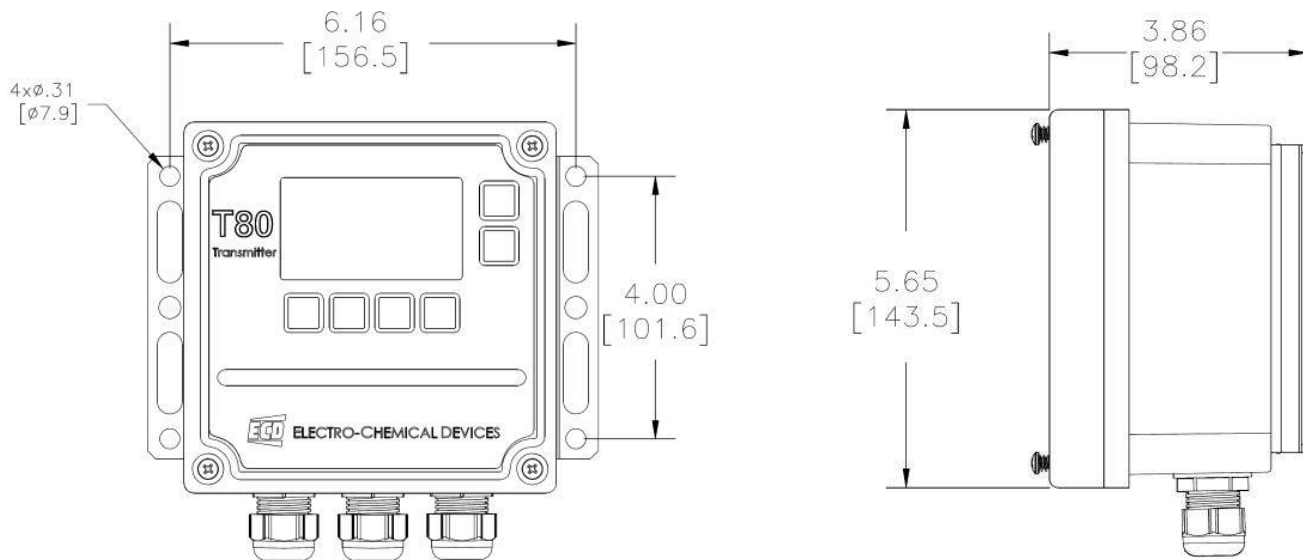

Rail Mounting

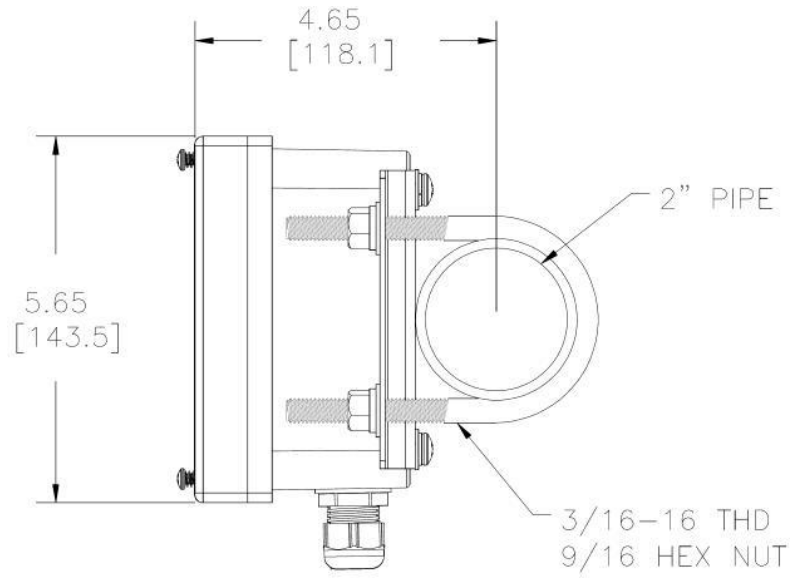
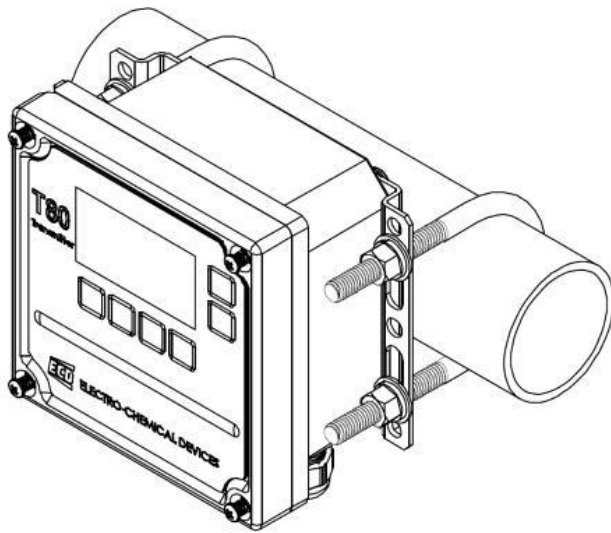

Panel Mounting

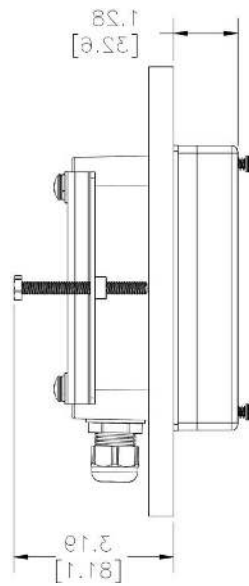
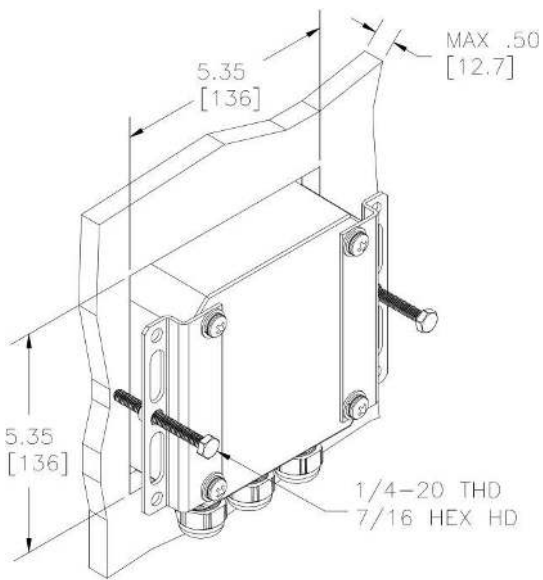

Cut Out: 5.35" x 5.35" (13.6cm x 13.6cm)

2.3 T80 WIRING



Electrical wiring should only be conducted by qualified personnel. See the T80 wiring diagram in figure 2.2X

Figure 2.2.1 Loop Powered Transmitter

Note: Loop powered 2-wire configuration not available for UV80 sensor

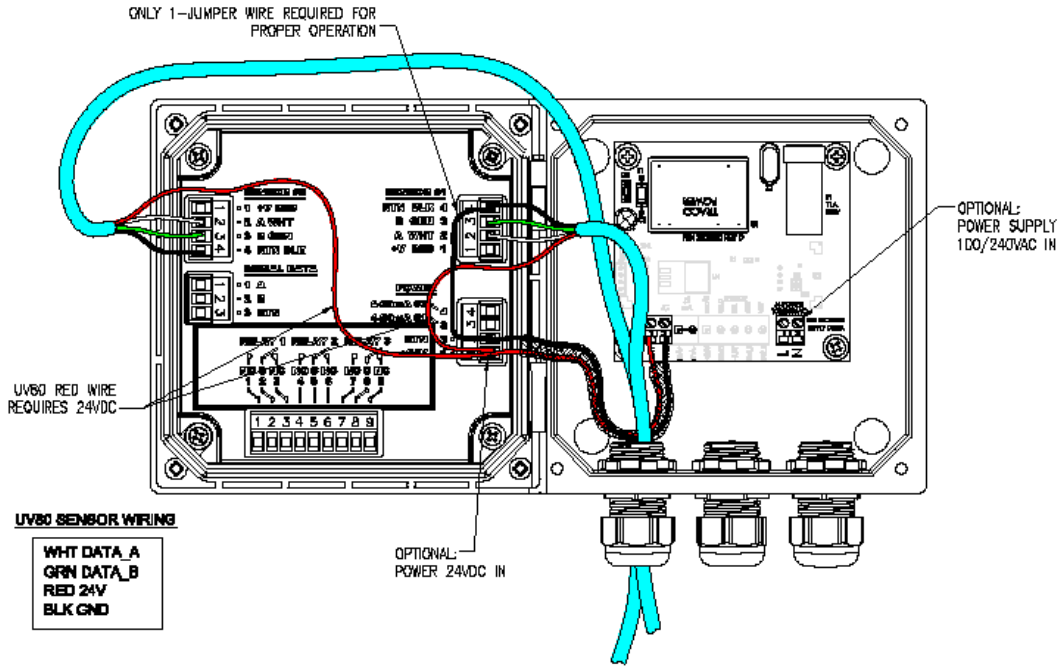
Figure 2.2.2 T80 Transmitter, 4-wire, 24VDC or 110/220 VAC, Sensor, and Modbus terminal block wiring



	Warning: RISK OF ELECTRICAL SHOCK
	Disconnect Power before opening instrument.
	WARNING Electrical installation must be in accordance with the National Electrical Code (ANSI/NFPA-70), Canadian Electrical Code, and/or any other applicable national or local codes.

2.2.1 WIRING, POWER

ECD recommends using thermoplastic, outdoor sunlight resistant jacketed cable wet location rated, and ½" flexible conduit. The power should be hard wired with a switch or breaker to disconnect the analyzer from the main power supply. Install the switch or breaker near the analyzer and label it as the Power switch for the analyzer.

Loop Powered (2 wire configuration)

Not available for UV80 sensors, only available with S80 sensors.

24VDC (4 wire configuration)

Attach the 24VDC power cable to terminals #1 and #2 as shown in Figure 2.2.2 and on the diagram inside of the T80 cover. Attach the 4-20 mA1 cable to terminals #3 (out) and #2 (return) single channel unit and attach the 4-20 mA2 cable to terminals #4 (out) and #2 (return) for a two channel instrument. Feed the cables through the gland fitting on the right side of the T80. Tighten the cable gland to provide a good seal to the cable. The instrumentation can be powered up at this point with no harm to the analyzer but it is best to wait until the sensor is installed.

110/220 VAC (4 wire configuration)

Attach power cable as shown in Figure 2.2.2 or as on the diagram inside of the T80 cover. Feed the cable through the gland fitting on the right hand side of the T80. Tighten the cable gland to provide a good seal to the cable. The instrument can be powered up at this point with no harm to the analyzer but it is best to wait until the sensor is installed.

2.2.2 WIRING, SENSOR

Attach the sensor wires as described on the diagram inside the T80 cover. Feed the sensor cable through the gland fitting on the left hand side of the T80. Do not use the same gland fitting for the AC power or Alarm/Relays. The green terminal strip connectors are detachable from the circuit boards. Remove the connector by pulling straight back from the circuit board.

NOTE: The UV80 Sensor requires +24 VDC (this is different than a S80 sensor). The sensor red wire should connect to the +24 VDC power terminal/connector only. Refer to wiring diagram and wiring instructions as follows:

Wire the UV80 sensor as follows: for 1 channel transmitters wire to sensor #1 terminal block, for 2 channel transmitters wire to sensor #1 and sensor #2 terminal block. Connect the white wire to the sensor terminal position 2 (A WHT), connect the green wire to terminal position 3 (B GRN), connect the black wire to terminal position 4 (RTN BLK), connect the red wire (longer) directly to the power terminal block +24V position 4 and this position is shared with the +24VDC input power wire (For AC powered transmitters, DO NOT connect AC power to this position) (DO NOT connect to the +V on sensor terminal this should remain unconnected). Next, connect a jumper wire from Sensor #1 terminal block position 4 (RTN BLK), this is shared position with the black sensor wire, and the other end of the jumper wire to the power terminal position 2 and this position is also shared with the +24VDC input power return (For AC powered transmitters, DO NOT connect AC power to this position)

2.2.3 WIRING, 4-20 MA OUTPUTS

24 VDC or 110/220 VAC powered instruments:

For instruments powered with 24VDC or the internet power supply, Model T80-XX-1X-XX (24VDC) and T80-XX-2X-XX (110/220 VAC), connect the 4-20 mA cable(s) to terminals #3 (out) for channel 1 and #2 (return) and to terminals #4 (out) for channel 2 and #2 (return).

Transmitters with HART® Communication can be wired as shown below. See HART® Communication menu in Appendix 9.2:

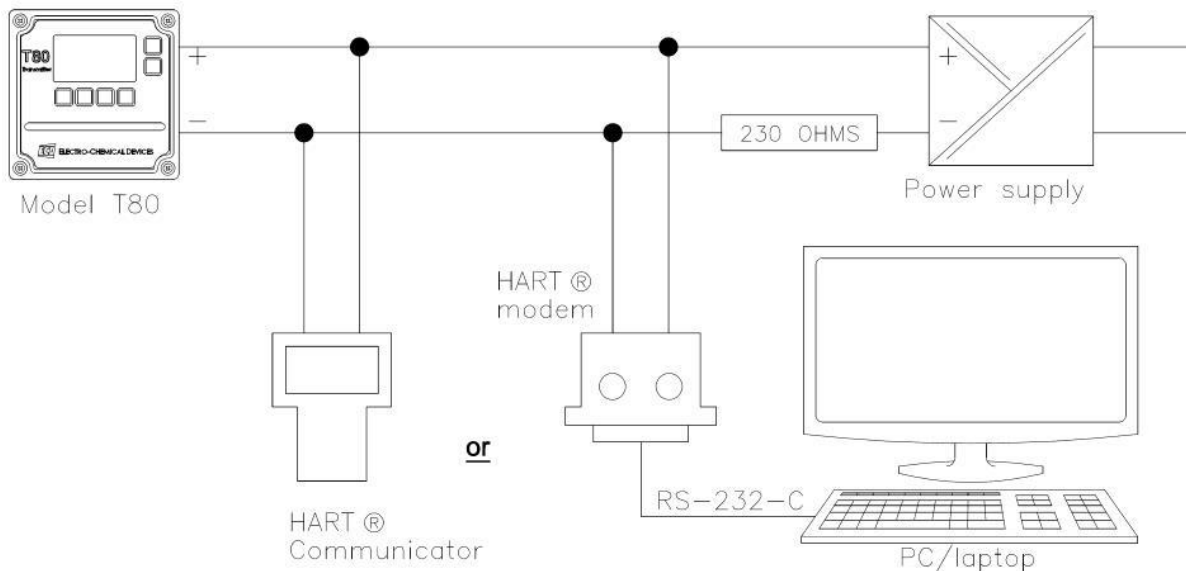

2.2.4 WIRING, CONTACT RELAY OUTPUTS

The standard configuration has three SPDT 230V 5 A Relays that can be wired with **normally open (NO)** or **normally closed (NC)**. The default configuration is set to use the relays as normally open.

2.2.5 WIRING, SERIAL OUTPUT MODBUS RTU

Attach the sensor wires as shown in figure 2.2.2 or as described on the diagram inside the T80 cover. Feed the sensor cable through the gland fitting on the left hand side of the T80. Do not use the same gland fitting for the AC power or Alarm/Relays.

3.0 OPERATION

The ECD Model T80 transmitter is an intelligent, single or dual channel multi-parameter transmitter designed for the online continuous measurement of pH, ORP, pION, conductivity, resistivity, Dissolved Oxygen, oil in water and/or organic load in a general purpose industrial environment. The Model T80 transmitter digitally communicates with any ECD S80, OIW80, and UV80 digital sensor. When an ECD sensor is connected to the transmitter it automatically configures the transmitter's menus and display screens to the measured parameter, with the exception of the OIW80 and UV80. For detailed instructions on all the functions of the T80 Transmitter, refer to the T80 instruction manual. This manual contains specific functions of the T80 in use with the UV80 Sensor.

4.0 CALIBRATION

The UV80 sensor was calibrated using a 2 point calibration for SAC at the factory before shipment. No Auto (2 point) calibration of the SAC reading should be required in the field. If the SAC reading needs to be zeroed to your process perform a standardization to the SAC. A standardization calibration should be performed on each Process Variable (PV) to properly correlate the PV to the SAC reading in your process.

To standardize the SAC or PV the T80 transmitter must be displaying the SAC or proper PV that is being standardized. PV options are TOC, COD, and BOD, to access each PV press the upper button to the right of the Display until the desired PV is being displayed. Follow the standardization procedure below.

4.1 AUTO CAL

The UV80 sensor is calibrated at the factory and should not require Auto Cal in the field. For detailed instructions on Auto Cal, contact the factory.

4.2 STANDARDIZE

If needed, Standardize the SAC to zero it to your process. Standardize PV correlates the SAC measurement to the PV. Default standardization values are as follows:

BOD / SAC	COD / SAC	TOC / SAC
0.429	1.487	0.586

Perform a Standardize calibration with the sensor installed in the process line or tank at the target measurement level.

Action	Prompt
Double Press any Button	MENU HOME, Hold is OFF
Press HOLD	Hold freezes 4-20 mA Output and locks Alarm Relays during Calibration
Press CAL	With the sensor in the process solution
Press NO	This is not a new sensor
Press STAND	Enter process measurement based on laboratory analysis or other means
Press ▲▼ NEXT	Use arrows and NEXT to enter the process value
Press OK	Accept Value
Press YES	Stand Cal Complete
Press OK	Back to Cal Menu
Press HOME	Hold is ON (Press HOLD to turn off Hold)
Press HOLD	Turn off Hold
Press EXIT	Main Display

4.3 MANUAL CAL

The UV80 sensor is calibrated at the factory and should not require Manual Cal in the field. Manual Cal adjusts the SLOPE and OFFSET, where sensor output = sensor voltage * SLOPE + OFFSET.

Action	Prompt
Double Press any Button	MENU HOME, Hold is OFF
Press HOLD	Hold freezes 4-20 mA Output and locks Alarm Relays during Calibration
Press CAL	Place Sensor in Air or with the sensor in the process solution
Press MANUAL	OFFSET or SLOPE
Press SLOPE	Enter SLOPE Value
Press ▲▼ NEXT	Use arrows and NEXT to adjust the slope value
Press OK	Accept Value
Press YES	Manual Cal Complete
Press OK	Back to Cal Menu

Action	Prompt
Press HOME	Hold is ON (Press HOLD to turn off Hold)
Press HOLD	Turn off Hold
Press EXIT	Main Display

5.0 MAINTENANCE

The UV80 response can become sluggish due to coating from materials in the process solution. Periodic cleaning will minimize drift and maintain the sensors response.

CLEANING

The most important maintenance item is keeping the optically clear window clean. The UV80 wiper will clean the surface of the sensor and also the sensors are fairly robust and can be cleaned with alcohols, detergents or very diluted acids to remove coatings caused by greases, oils or films. **Do not use abrasive cleansers or aggressive solvents such as MEK, Toluene, Acetone, or trichloroethylene on UV80 sensors.** A soft tooth brush or paper towel should be used to remove soft coatings.

WIPER REPLACEMENT

The wiper and/or wiper assembly arm can be replaced in the field. Order the following Wiper Kit for replacement. Each kit includes a 1.5 mm hex key.

6.0 SPECIFICATIONS

6.1 UV80 / ORGANIC LOAD SENSOR

Measuring principle:	UV254 absorption photometry
Measuring Range:	Low range COD 0 - 370 mg/l eq., KHP / TOC 0 - 150 mg/l High range COD 0 -1000 mg/l eq., KHP / TOC 0 - 400 mg/l
Repeatability:	± 2.5% of full scale
Reproducibility:	± 2.5% of full scale
Limit of Detection:	0.75 ppm (KHP equivalent)
Sampling Interval:	1 second
Process Temperature Range:	5 - 50°C (41 - 122°F)
Process Pressure Range:	15 – 88 psi
Dimensions:	Diameter 50 mm, length 176 mm
Weight:	1 kg (2.2 lbs)
Process Connection:	3/4" NPT
Ingress Protection Level:	IP68
Cable Length:	10ft. (3.0 m), 20ft (6.1 m), 30ft (9.1 m) cables
Wiper interval:	15 minutes
Wiper duration:	6 seconds
Wiper set screw size:	1.5 mm

6.2 T80 TRANSMITTER SPECIFICATIONS

Input specification:	Digital protocol, all ECD S80 sensors Optional analog to digital converter, 5 inputs [mV+, mV-, solution ground, temp + temp – (100 K-ohm)]
Accuracy:	2% of reading
Output Signals:	Non-isolated 4-20 mA output (standard, one per Channel), Fault Condition: 3.5 mA, 22 mA or none Modbus RTU (standard) HART® (optional)
Contact Relays:	(optional) Three (3) SPDT, 1 form C, 250 VAC, 10 Amp resistive maximum, relays, user configurable as Hi/Lo alarms with expiration timer, Periodic Timers or Fault alarms
Display:	128 x 64 pixels (2.75" x 1.5") LCD, Black on Grey background on loop powered instruments, Blue on White background with LED backlight on 100-250 VAC and 24 VDC powered instruments, English or icon based menus, numeric and graphical displays
Enclosure:	Beige Polycarbonate, IP65, weatherproof, ½ DIN, (L x W x D) 5.7: X 5.7" X 3.5" (14.4cm X 14.4cm x 9.0cm)
Power:	24 VDC (18-36 VDC) or 100-240 VAC, 50/60 Hz

Environmental Conditions

Ingress Protection:	Outdoor use (IP65)
Ambient Temperature:	-20°C - 70°C (24 VDC Models) -20°C - 60°C (100-240 VAC Models)
Storage Temperature:	-30°C - 85°C
Relatively Humidity:	0 – 80%, up to 31°C Decreasing linearly to 50% RH a 40°C
Altitude:	Up to 2000 m (6500 ft)
Mains Supply Voltage:	Fluctuations up to ±10% of the nominal voltage Transient over voltages: CAT II Pollution Degree: 2

Model UV80 Sensor, Part # Guide						
UV80	Sensor Style (optical configuration)					
	1	Flat Surface optics				
		Process Connection				
		0	None			
		1	1 ¼" MNPT PVC Gland Fitting			
		2	Flow Through Cell, 2 x 2" FNPT entries, 1 x1 " FNPT sensor port			
		3	Flow Through Cell, 2 x ¾" slip entries, 1 x1 " FNPT sensor port			
		4	Flow Through Cell, 2 x ¾" FNPT entries, 1 x1 " FNPT sensor port			
		Cable Length				
		01	10 ft (3.0 m)			
		02	20 ft (6.1 m)			
		03	30 ft (9.1 m)			
		Measurement Ranges				
		1	COD 0 - 370 mg/l eq., KHP / TOC 0 - 150 mg/l			
		2	COD 0 -1000 mg/l eq., KHP / TOC 0 - 400 mg/l			
		UV80-	1	0	01	2

7.0 TROUBLESHOOTING

Symptom	Probable Cause	Remedy
Blank Display	No Power	Check power source, 24 VDC loop, 24VDC, 110/220VAC
	Sensor Failure, causing power draw down below transmitter threshold	Unplug sensor from transmitter, replace sensor if instrument powers up.
Incorrect Readings	Sensor needs calibration	Perform a standardization calibration. See INFO for calibration log
"Looking For Sensor" prompt	Lost connection between sensor and transmitter	Check sensor connection to transmitter: loose connector? Visually inspect cable for cuts or crushed areas, replace sensor if cable is compromised

8.0 PARTS AND ACCESSORIES (T80)

8.1 FRONT PANEL CONTROL BOARD EXPLODED, WITH RELAYS

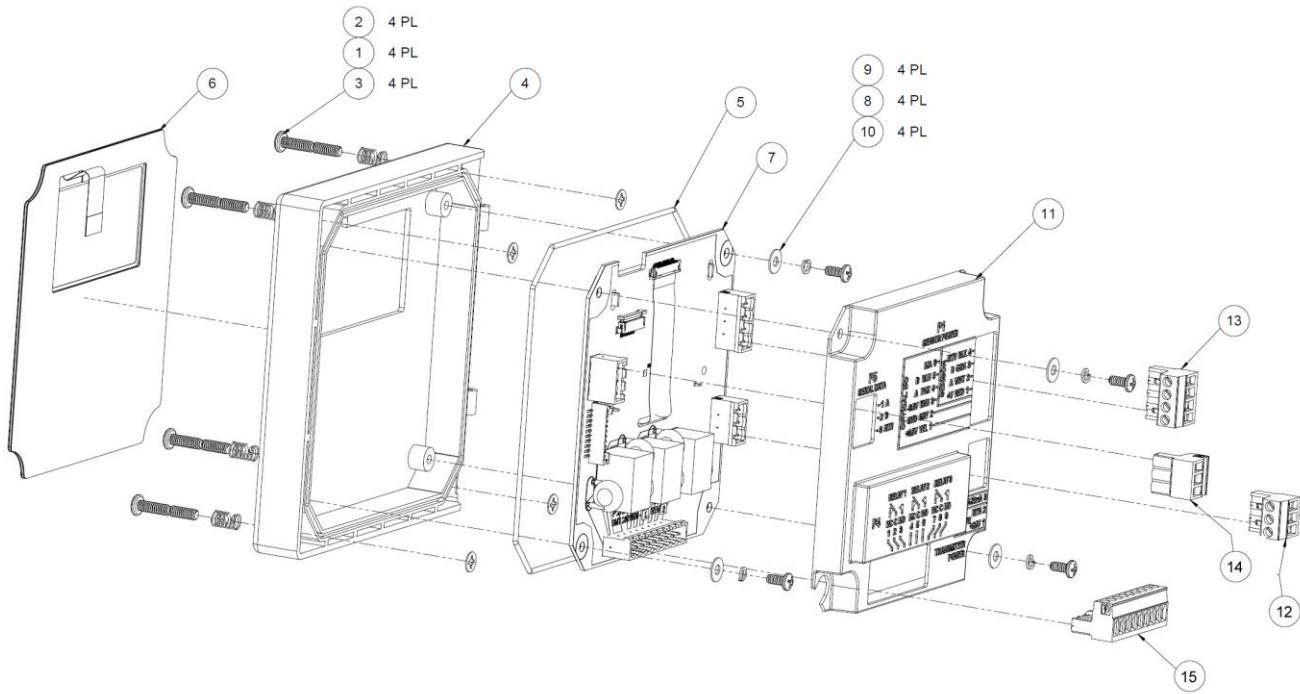

Item #	Part #	Description
1	9630005	Spring, Mounting Screw Set
2	9870621	Retaining Washer, Mounting Screw Set
3	3600390	8-32 x 1" SS Screw, Mounting Screw Set
4	3400152	Front Housing
5	9560005	Sealing O-ring, grey silicone
6	9240503-1	Touch pad membrane
8	9870650	Locking Washer, PCB Screw Set
9	9730605	6-32 x 5/16" SS Screw, PCB Screw Set
10	9870620	Flat Washer, PCB Screw Set
11	3400006	Control Board Cover
12	9090112	24 VDC, 4-20 mA Terminal Black/2 pins
13	9090114	Sensor Terminal Block/4pins
14	9090113	Serial Connection Terminal Block/3 pins
15	9090119	Relay Connection Terminal Block/9 pins

8.2 TRANSMITTER CASE, BACK WITH CABLE GLANDS

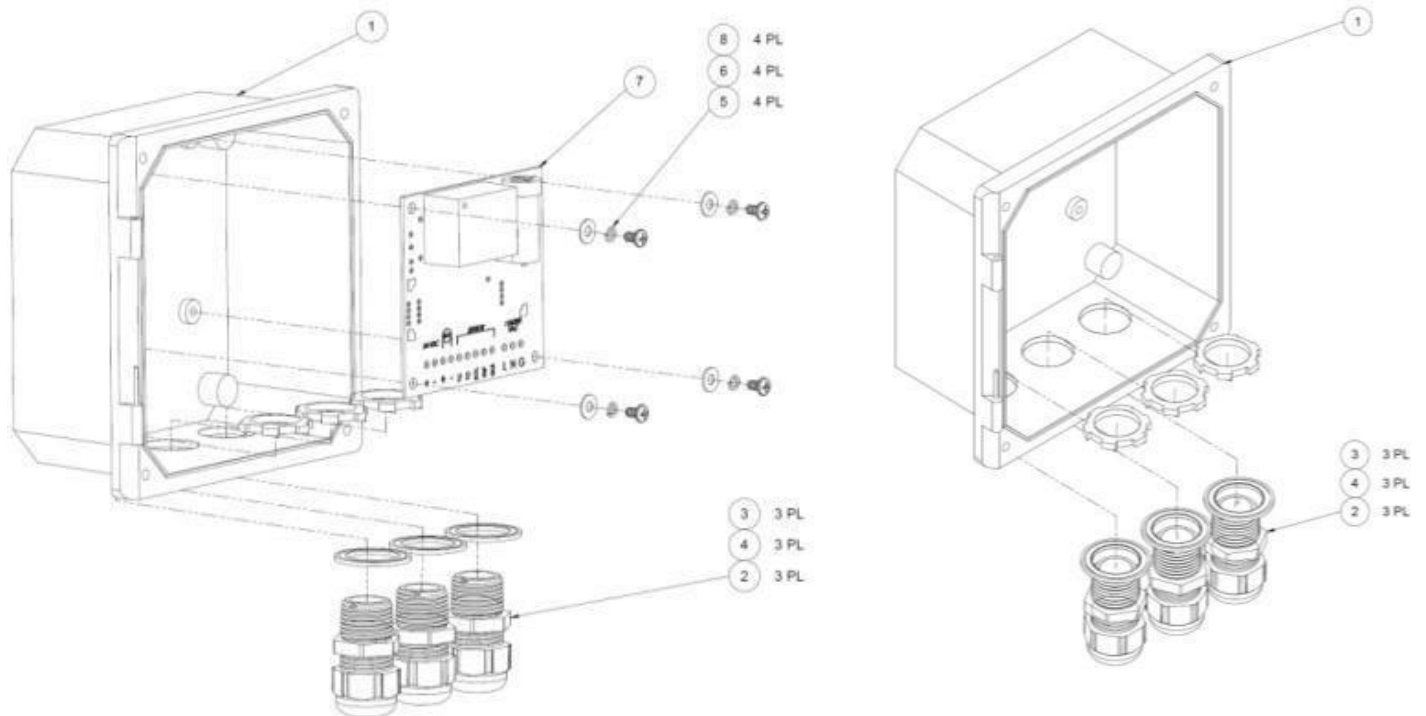

Item #	Part #	Description
1	3600449	Transmitter Case
2	9360005	PVC Cable Gland, 1/2" NPT, Grey
3	9300034	Locking Nut, 1/2" NPT, Steel
4	9300017	Sealing ring, 1/2" elastomer
5	9870650	Split Washer, PS mounting
6	9870620	Flat Washer, PS mounting
7	2101820-1	Power Supply Board
8	9730604	6-32 x 1/4" screw, SS, PS mounting

8.3 REPLACEMENT PARTS

Part #	Description
2000002-2	Front Panel, AC/DC Powered
2101820-1	Power Supply Board, 110/220 VAC Input
3400006	Control Board Cover
9090112	Connector Plug, 2 Position (Loop, AC/DC, or Hart Versions)
9090113	Connector Plug, 3 Position (Loop or AC/DC Versions)
9090114	Connector Plug, 4 Position (Loop, AC/DC or Hart Versions)
9090119	Connector Plug, 9 Position (AC/DC Version)
9240503-1	Front Panel Membrane Switch
9300017	Sealing ring, Cable Gland
9300034	Locking Nut, Cable Gland
9360005	Fitting, Cable Gland
9830214	Screw, Front Panel
1000375-1	UV80 Spare Wiper Kit, low range
1000375-2	UV80 Spare Wiper Kit, high range

8.4 ACCESSORIES

Part #	Description
2000006	Kit, Universal Mount
2000007	Kit, Handrail Mount
2000008	Kit, Panel Mount
1000300-1	4-20 mA USB Data Logger
9130007	Replacement Battery for Data Logger
1000260-1	Sunshield for Pole Mount
1000260-2	Sunshield for Rail Mount



1500 North Kellogg Drive • Anaheim, CA 92807 •
+1-714-695-0051 • FAX +1-714-695-0057 •
ecdi.com