



Instruction Manual

Model CA-6 Analyzer



The information and technical data disclosed in this document may be used and disseminated only for the purposes and to the extent specifically authorized in writing by EDC Analyzers. EDC Analyzers reserves the right to change published specifications and designs without prior notice.

Part No. CA6 IM

PREFACE

Purchasing products from ECD Analyzers LLC, Inc. provides you with the finest liquid analytical instrumentation available. If this is your first purchase from ECDA, please read this manual before installing and commissioning your new equipment.

If there are any questions concerning this equipment, please contact your local ECDA representative, or the factory directly at:

ECD Analyzers LLC
1500 North Kellogg Dr.
Anaheim, CA 92807 USA
Telephone: +1-714-695-0051
FAX: +1-714-695-0057
Website: www.ECDAnalyzers.com
Email: support@ECDAnalyzers.com

TABLE OF CONTENTS

PREFACE	ii
TABLE OF CONTENTS.....	iii
TERMS AND CONDITIONS OF SALE	vi
RETURNED GOODS POLICY	ix
IMPORTANT SERVICE INFORMATION	x
UNPACKING THE INSTRUMENT.....	x
1.0 OVERVIEW.....	1
CONTENTS:.....	1
1.0.1 CA-6 Technical Specifications.....	2
1.1 Safety Precautions, Instructions and Hazards	3
1.1.1 General information.....	3
1.1.2 List of warnings and potential dangers.....	3
1.1.3 Reagents.....	4
1.1.4 Sample Stream	5
1.1.5 Waste disposal of the liquid reagents for the colorimetric reaction.....	5
1.1.6 Analyzer General Hazards.....	5
2.0 INTRODUCTION – Analyzer Description.....	7
2.1 Applications.....	7
2.2 Working principle: Lambert-Beer law	7
2.2.1 Absorption photometry (Colorimetry):.....	8
2.3 Analysis Cycle.....	9
2.3.1 Typical Run Sequence:	9
2.3.2 Settings.....	10
2.3.3 Programmable Functions.....	11
2.4 Components.....	15
2.4.1 Fast-loop reservoir	15
2.4.2 Sampling Pump	16
2.4.3 3 Way Valve.....	16
2.4.4 Micro Peristaltic Pumps	16
2.4.5 Mixing Pump	16

2.4.6 Pinch Valve	16
2.4.7 Colorimetric Reaction Cell.....	17
2.4.8 Sample Drain	17
2.4.9 Electronic Components	17
3.0 OPTIONS.....	18
3.1 Dilution Module	18
3.2 Oxidation/Digestion Module.....	19
4.0 INSTALLATION.....	21
4.1 Unpacking and Inspecting	21
4.2 Analyzer Handling	21
4.3 Location and Mounting Instructions.....	21
4.4 Pre-Installation.....	21
4.5 Electrical Connections.....	22
4.5.1 General information.....	22
4.5.2 AC Power Connections.....	23
4.5.3 Signal Output Connections – TB (4-20 mA, alarm, aux, Modbus TCP/IP, Modbus RS485).....	23
5.0 REAGENTS PREPARATION	26
6.0 ANALYZER INITIAL START-UP	27
6.1 Sample and Drain Tubing Connections.....	27
6.2 Powering, Priming and Starting the Analyzer	28
7.0 CALIBRATION.....	29
7.1 Blank Calibration (Zero Point).....	29
7.2 Slope Calibration (Factor)	30
7.3 Step by Step Manual Calibration	30
8.0 USER INTERFACE	32
8.1 Touch Screen Display	32
8.2 Passwords (****)	32
8.3 Main Screen	33
8.3.1 Status Modes	34
8.3.2 Menu Buttons	34
8.4 RUN MENU.....	35

8.4.1 START ON-LINE?	35
8.4.2 CYCLE Ch1 / CYCLE Ch2 / Cycle Extra	35
8.4.3 EMERGENCY STOP	35
8.5 DISPLAY MENU	36
8.5.1 Display Process Values	36
8.5.2 Chart	36
8.5.3 Manual Step	36
8.6 PROGRAM MENU	37
8.6.1 Analysis Cycle	37
8.6.2 Extra Cycle	38
8.6.3 Settings Menu	38
8.6.2 Calibration Menu	38
8.7 SERVICE MENU	39
8.7.1 Method of Operation	40
9.0 MAINTENANCE	41
9.0.1 Visual check	41
9.0.2 Monthly	41
9.0.3 Every 4-6 months	42
9.0.4 Annual	42
9.1 Sample Pump tubing replacement	42
9.2 Micro Peristaltic Tubing Replacement	43
9.3 Cleaning the Colorimetric Cell	45
10.0 ANALYZER START UP AND SHUT DOWN	47
FIRST START-UP PROCEDURE	47
SHUT DOWN PROCEDURE	47
11.0 DIMENSIONAL DRAWING	48

TERMS AND CONDITIONS OF SALE

1. ACCEPTANCE.

If this writing differs in any way from the terms and conditions of Buyer's order or if this writing is construed as an acceptance or as a confirmation acting as an acceptance, then Seller's acceptance is **EXPRESSLY MADE CONDITIONAL ON BUYER'S ASSENT TO ANY TERMS AND CONDITIONS CONTAINED HEREIN THAT ARE DIFFERENT FROM OR ADDITIONAL TO THOSE CONTAINED IN BUYER'S WRITING.** Further, this writing shall be deemed notice of objection to such terms and conditions of Buyer. If this writing is construed as the offer, acceptance hereof is **EXPRESSLY LIMITED TO THE TERMS AND CONDITIONS CONTAINED HEREIN.** In any event, Buyer's acceptance of the goods shall manifest Buyer's assent to Seller's terms and conditions. No addition to or modification of these terms will be effective, unless set forth in writing and agreed to by Seller.

2. WARRANTIES AND REMEDIES

a. Warranty. Seller warrants to Buyer that it holds and will pass marketable title to the goods sold hereunder. Seller warrants to Buyer that the items and components manufactured by Seller will be free from defects in material and workmanship (subject, however, to tolerances and variances permitted by the trade hereunder) for a period one (1) year for non-consumable products. Consumable electrodes and sensors have a conditional warranty based shelf life and process conditions and is determined by Seller.

b. Exclusion and Conditions. Seller's obligations with respect to the express warranties and remedies contained herein are conditioned on the following: (i) Buyer's return of the non-conforming goods, if authorized by Seller; (ii) Buyer shall not assign its rights under these express warranties and any attempted assignment shall render such warranties, but not any disclaimers or limitations, void and the goods sold shall be sold **AS IS**; and (iii) all products shall be carefully inspected for damage by Buyer upon receipt, be properly calibrated for Buyer's particular use, and be used, repaired, and maintained by Buyer in accordance with the instructions set forth in Seller's product literature. Repair and maintenance by non-qualified personnel, product subjected to misuse or negligence, and/or damaged during shipment will invalidate the warranty, as will the use of non-approved consumables or spare parts. As with any other sophisticated product, it is essential, and a condition of Seller's warranty, that all personnel using the product be fully acquainted with its use, capabilities and limitations as set forth in the applicable product literature.

3. DISCLAIMER OF IMPLIED WARRANTIES. Seller gives no warranties except those expressly contained herein. Seller **disclaims** all other warranties implied by law usage of the trade, course of dealing or course of performance including, but not limited to, **the Implied warranties of MERCHANTABILITY and fitness for a particular purpose.**

4. LIMITATIONS OF LIABILITY. The following limitations of Seller's liability are acknowledged by the parties to be fair and reasonable and shall apply to any act or omission hereunder, and to any breach of this contract of which these terms and conditions form a part:

a. Disclaimer of Damage. In no event shall Seller be liable for special, indirect, consequential or incidental damages whether arising under contract, warranty, tort, strict liability or any other theory of liability. Such damages include but are not limited to loss of profits, loss of use of goods, damage to property, and claims of third parties.

b. Suitability. Buyer acknowledges that it alone has determined the intended purpose and suitability of the goods sold hereunder. It is expressly agreed by the parties that any technical or other advice given by the Seller with respect to the use of the goods or services is given without charge and at Buyer's risk; therefore Seller assumes no obligation or liability for the advice given or results obtained.

c. Notice and Time of Claims.

i. Buyer agrees to check and inspect all products against shipping papers and for damage or shortage upon receipt of goods at destination.

ii. Every claim for shortage, damage in transit, or other cause visible upon inspection shall be deemed waived by the Buyer, or the Buyer's customer in the case of resale, unless delivered in writing to Seller by Buyer thirty (30) days from the tender of delivery of the goods to Buyer, provided, however, that claims for shortage must be made within seven (7) days of receipt.

iii. The parties expressly waive the statute of limitations and agree that any legal proceeding for any breach of this contract shall be waived unless filed within one (1) year after the accrual of the cause of action thereof.

5. FORCE MAJEURE. Seller shall not be liable for any delay in delivery, or failure to deliver, due to any cause beyond the Seller's control including but not limited to fires, floods, or other forces of the elements; strikes, or other labor disputes; accidents to machinery; acts of sabotage; riots; precedence or priorities granted at the request or for the benefit, directly or indirectly of the federal or any state government or any subdivision or agency thereof; delay in transportation or lack of transportation facilities; restrictions imposed by federal, state or other governmental legislation or rules or regulations thereof. If Seller, in its sole discretion, determines that Seller's performance hereunder would result in a loss to Seller's on this sale as computed under Seller's normal accounting procedures because of causes beyond Seller's control, then the Seller may terminate this agreement in whole or in part without liability for any delay in the delivery of, or failure to deliver, the goods sold hereunder

6. TAXES AND OTHER CHARGES. The Buyer will pay, or reimburse Seller if it pays, any and all taxes or tariffs or any other similar charges imposed upon this contract, the goods covered hereby or the delivery or use or resale thereof.

7. FREIGHT CHARGES. If the sale hereunder is other than F.O.B. Seller's facility, this acknowledgement is based upon the freight charges now in effect. In the event of an increase or decrease in applicable freight charges before the goods are shipped, such charge in freight will be for the Buyer's account.

8. PRICES AND DELIVERY. Prices quoted herein are F.O.B. shipping point. Deliveries specified are only our best estimate and are subject to change. This quotation is based upon freight charges now in effect. Buyer will be invoiced at the freight charge prevailing at the date of shipment. Prices are firm for orders meeting Seller's normal shipping schedules. If shipments are held or postponed for any reason other

than Seller's fault, and a price increase becomes effective during the period of such hold or postponement, the increase will apply to all shipments that are held or postponed thirty (30) days or more from the effective date of the increase.

9. PAYMENTS. If in the judgment of Seller the financial condition of Buyer at any time prior to shipment does not justify the terms of payment specified, Seller may cancel the order, withhold shipment, and/or require full or partial payment in advance. If payment is not made when due, Seller may suspend all future delivery or other performance with respect to Buyer without liability or penalty and, in addition to all other sums payable hereunder, Buyer shall pay to Seller (i) the reasonable costs and expenses incurred by Seller in connection with all actions taken to enforce collection or to preserve and protect Seller's rights hereunder, whether by legal proceedings or otherwise, including without limitation reasonable attorneys' fees, court costs and other expenses and (ii) interest on all amounts unpaid after 30 days charged at the monthly rate of 1-1/2% or the highest rate permitted by law, whichever is lower.

10. CANCELLATION OR ALTERATION. Buyer may not alter or cancel any order without Seller's written consent. For any order altered or cancelled with Seller's consent, Buyer must pay for all expenses and labor incurred up to the time of Seller's consent, plus a reasonable percentage for profit. Any order delayed or deferred by Buyer will be subject to price escalation for increased costs of production, and any other expenses caused by the delay. Material on such orders will be stored at Buyer's risk. Seller reserves the right to invoice Buyer and require payment before shipment of any delayed or deferred order.

11. TITLE AND RISK OF LOSS. Title and risk of loss shall pass to buyer at Anaheim, California, unless otherwise specified in the contract. If delivery is made by common carrier, risk of loss shall pass upon delivery to the carrier. Claims for loss or damage in transit must be made by Buyer to the carrier. Seller accepts no responsibility for loss or damage to product in transit.

12. PATENT OR TRADEMARK INFRINGEMENT. If the goods sold hereunder are to be prepared for manufacture according to Buyers specification, Buyer shall indemnify Seller against any claim or liability for patent, trademark, service mark or trade name infringement on account of preparation, manufacture and/or sale.

13. NON-WAIVER. If Government Contract Regulations require the addition, deletion, or modification of these terms and conditions upon prior notification to Seller and Seller's written acceptance thereof, such changes shall become a part of these terms and conditions. Seller shall not be bound by any Government Contract Regulations applicable to Buyer's contracts with the U.S. Government unless Buyer has expressly acknowledged, on the face of this document, the applicability of such Regulations to the transaction between Buyer and Seller contemplated herein. Absent such acknowledgement, Seller is making the assumption in issuing this document that no such Regulations apply.

14. JURISDICTION. All such disputes shall be resolved in a court of competent jurisdiction in Orange County, California. Buyer hereby consents to the jurisdiction of the State and Federal Courts sitting in Orange County. Notwithstanding the above, should either party contest the jurisdiction of such courts, the other party may institute its suit in any court of competent jurisdiction.

15. APPLICABLE LAW. All questions arising hereunder or in connection with the quotations or any order submitted in connection therewith and/or the performance of the parties hereunder shall be interpreted and resolved in accordance with the laws of the state of California without regard to its conflict of law provisions and excluding the United Nations Convention on the International Sale of Goods.

Revision A

RETURNED GOODS POLICY

All requests for returned goods must be initiated through our Customer Service Department. Please call our phone number 1-714-695-0051 with the specifics of your request. The following conditions must be satisfied for consideration of applicable credit for the return of products purchased from ECD Analyzers:

- 1) The item is unused and in the original package.
- 2) The item was shipped directly from ECD Analyzers.
- 3) The item has not been damaged in shipment to ECD Analyzers.
- 4) The item is saleable;
 - a) Items containing date-sensitive parts such as electrodes, must be returned within 1 month of the invoiced date.
 - b) Items without date-sensitive parts must be returned within 3 months of the invoiced date.

A Return Authorization Number must be obtained from Customer Service and provided on all paperwork and packaging. To obtain a Return Authorization Number, please provide the reason for return, the date of purchase, your original purchase order number, and either our order number (on the packing slip or invoice) or our invoice number. The issuance of a Return Authorization Number is a verbal approval for return only and does not guarantee credit or allowance. Returned goods must be received within 30 days of the issuance date of the Return Authorization Number or it will become null and void.

Necessary physical and mechanical inspection is completed upon receipt of the item. Applicable credit or equivalent allowance is determined after inspection of the returned item. If all of the above conditions are met, and the item has been approved to return to our stock, a restocking charge of 25% of the purchase price is deducted from the applicable credit.

IMPORTANT SERVICE INFORMATION

Use only factory authorized components for repair. Tampering or unauthorized substitution of components may adversely affect the operation of this product and may void the warranty.

If service or repair is required, please obtain the serial number(s) or sales order number of the product(s) in question and contact ECDA's Service Department at:

+1-800-729-1333 (USA/Canada) or +1-714-695-0051
or email support@ecdanalyzers.com

A Return Material Authorization (RMA) number must be obtained from the service department before returning any material to ECDA. All material returned to ECDA shall be shipped prepaid to the factory.

UNPACKING THE INSTRUMENT

Your ECD Analyzers instrument has been carefully packaged to protect it from damage during shipment and dry storage. Upon receipt please follow the procedure outlined below.

1. Before unpacking, inspect the condition of the shipping container to verify proper handling by the carrier. If damage is noted, save the shipping container as proof of mishandling for the carrier.
2. Check the contents of the shipping container with the items and quantities shown on the packing list. Immediately report any discrepancies to ECDA.
3. Save the original packing material until you are satisfied with the contents. In the event the product(s) must be returned to ECDA, the packing material will allow you to properly ship it to ECDA.
4. Familiarize yourself with the instrument before installation, and follow proper installation and wiring procedures.

1.0 OVERVIEW

Thank you for purchasing our Model CA-6 Analyzer.

The CA-6-Analyzer was designed and manufactured to be an easy-to-use, high-sensitivity and low-cost measuring instrument. This Analyzer should give you many years of reliable and hassle-free operation with regular care and maintenance.

This document is the Operating Manual for the Analyzer. We recommend that you enter the information below the first opportunity you get.

Product Name	CA-6 Analyzer
Product Model	CA-6 Analyzer
Purchase Date	
Serial No	SO#
Warranty Period, Begin-End Dates	1 year from date of shipment
Password	Service 1111, Admin 6699
Contact Details, Your Distributor	
Contact Details	ECD Analyzers LLC Phone: +1-714-695-0051 Fax: +1-714-695-0057 Email: support@ecdanalyzers.com Internet: www.ecdanalyzers.com

CONTENTS:

1. CA-6 Colorimeter
2. Tubing Kit, Door Key
3. Reagent Bottles
4. CA-6 Instruction Manual

REVISION INFORMATION:

- Revision C (6/21)
- Updated CA6 Analyzer image
 - New dimensional drawing included

1.0.1 CA-6 Technical Specifications	
Analysis:	Colorimetric parameters
Method:	Photometric differential absorbance
Measuring range:	Contact factory for specific colorimetric measurements
Response time:	5-20 minutes cycle plus wait time depending on specific measurements
Repeatability:	+/- 2% on absorbance value with sample turbidity < 80 NTU
Drift:	+/- 2% per month on the absorbance measurement
Power supply:	110-220Vac, 50-60 Hz 80 VA
Mounting:	Wall mounting or with optional bench support
Operating temperature:	5°C to 45°C (41-113°F)
Cabinet:	Cold Rolled steel, epoxy powder coated
Dimensions:	15"W x 24"H x 8.25"D (380mm W x 600mm H x 210mm D)
Weight:	Approx. 37lbs (19 kg)
Reagent consumption:	Contact factory for specific colorimetric measurements
Output:	4-20 mA, RS485, Optional Ethernet, Profibus
Alarms:	4 configurable relays
Sample	
Inlet sample pressure:	Atmospheric
Outlet sample pressure:	Atmospheric, waste tubing $\frac{3}{8}$ " O.D. x $\frac{1}{4}$ " I.D.
Sample flow for the fast loop reservoir:	100-500 ml / min
Connections:	To the fast loop reservoir with flexible tubing $\frac{1}{4}$ "O.D. x $\frac{1}{8}$ " I.D.

1.1 Safety Precautions, Instructions and Hazards

	<p>This Manual contains important information required to install, start up and operate the Model CA-6 Analyzer. Please read the entire manual carefully before installing or placing the analyzer into service!</p>
---	--

1.1.1 General information

Pay attention to all Caution and Danger labels present on the analyzer and all Caution and Danger statements written in this manual.

ECD Analyzers LLC shall not be liable for errors contained herein and/or for the incorrect use of the analyzer. The analyzer's users must read the User's Manual before placing the CA6 analyzer into service. Observe the instructions and follow all national and local regulations and laws regarding workers health and safety.

The use, maintenance and service of this analyzer is restricted to qualified personnel, fully trained in the analyzer's operations. These personnel are intended to be physically and mentally fit and not under the influence of drugs or alcohol.

When the analyzer is not in use, it should be protected from intentional or unintentional powering up, using a proper power switch.

Failure to do so or non-observance of hazards or dangers warnings could result in death or serious injury to the operators or damage to the analyzer.



Before using the analyzer it is necessary to visually check for damage to the safety devices and to report them to your supervisor even if they don't cause analyzer stop or malfunction.



All of the analyzer's components are installed inside a metallic enclosure; a special key is required to open the door, only qualified maintenance personnel should have access to the key.

1.1.2 List of warnings and potential dangers

The table below is a list of Hazard and Danger Warning Labels found on the analyzer and/or in this manual. Damaged or illegible labels should be replaced with new ones by the analyzer owner.

Table 1-1: List of Hazards and Dangers

	<p>Poisonous Substances: Very hazardous to health when inhaled, swallowed or when they come in contact with the skin. May even lead to death. Danger! Avoid contact with the human body and immediately contact a physician in case of contact.</p>	<p>Involved parts:</p> <ul style="list-style-type: none"> · fluids section · reagent containers
	<p>Hazard of electrical shock This symbol is used to represent a hazard of severe electric shock or electrocution. All adjustments and maintenance on electrical devices labeled with this symbol should be made by qualified personnel in accordance with national or local regulations. Qualified Personnel means a person who has been fully trained and</p>	<p>Involved parts:</p> <ul style="list-style-type: none"> · main power supply · peristaltic pump motor · input terminal

	has professional experience to avoid electrical hazards and dangers. To avoid potentially fatal electrical shock and/or analyzer damage always disconnect input power to analyzer before servicing.	
	<p>Hazard of chemical burns</p> <p>This symbol is used to represent a hazard of severe burns or injury due to handling of dangerous chemicals. All handling, maintenance and filling operations of chemicals labeled with this symbol should be made by qualified personnel in accordance with national or local regulations. Qualified Personnel means a person who has been fully trained and has the professional experience to avoid chemical hazards and dangers. Before handling the chemicals or proceeding with service operations, read the material safety data sheets supplied with each chemical and follow all necessary precautions when handling.</p>	<p>Involved parts:</p> <ul style="list-style-type: none"> · Fluids section · reagent containers
	<p>Harmful</p> <p>Specific warning depending on the parameter analyzed and the chemical colorimetric method used. See appendix of the manual.</p>	<p>Involved parts:</p> <ul style="list-style-type: none"> · Fluids section · Reagent containers

1.1.3 Reagents

The Model CA-6 Analyzer is based on colorimetric analysis methods, using chemical solutions. For the dangers and hazards regarding the chemicals used for the analysis, please contact ECDA factory.

Make sure that proper safety precautions are taken (e.g. using safety gloves and glasses) during handling the chemical solutions and the reagents containers / bottles.

Read carefully the Material Safety Data Sheets of each chemical.

All bottles of the reagents must be labeled with the specific hazards and dangers labels.

1.1.4 Sample Stream

Take appropriate precautions to avoid direct contact with sample stream. It is the responsibility of the user to collect all the information and take all the precautions regarding physical, chemical, radiation and/or biological hazards and dangers coming from sample stream and/or sample vapors. It is also responsibility of the user to collect all the information and potential hazards regarding the chemical and physical compatibility of sample stream with the analyzer materials.

Table 1-2: List of materials used in the Model CA-6 Analyzer

Pump tubing	Silicon or Norprene®
Fittings	PP
Connection tubing	Norprene® / Silicon
Colorimetric cell	Glass
Micro peristaltic Pump	PVC / Stainless Steel / Plexiglass
Mixing membrane pump	PP / EPDM
Pinch valve	Norprene® / Silicon tubing

1.1.5 Waste disposal of the liquid reagents for the colorimetric reaction

The liquid from the drain of the colorimetric cell may need to be collected in a separate canister. For guidelines on disposal consult the requirements of the Local Authority for chemical waste regulation. Arrange removal by a Disposal Company.

1.1.6 Analyzer General Hazards

1.1.6.1 Electrical precautions and hazards

Power to the CA-6 Analyzer must be routed through an ON/OFF power switch.

Mind the electrical shock and/or electrocution labels placed on the analyzer.

All electrical devices powered by 110/220 VAC present the hazard of electrical shock or electrocution.

The analyzer enclosure is equipped with a door that requires a special key for opening to protect all the personnel involved in analyzer use and maintenance.

Only Qualified Service Personnel should have access to the key that opens the analyzer.

Before servicing the analyzer or any parts that are electrically powered, turn off the power to avoid the risk of electrocution.

Inside the analyzer's lower level, the electrical protection is IP2X. Analyzer's enclosure is IP54.

Protection against electrical shock is guaranteed by the grounding of all isolated metal surfaces.

Grounding terminal/screw is located inside the electrical enclosure, in Upper Left position.

It is the user's responsibility to periodically check the efficacy of analyzer's electrical ground.

In case of loss of power, the analyzer stops and automatically restarts as soon as power is returned.

1.1.6.2 Operating precautions and hazards

HAZARD: Mechanical hazards caused by moving parts such as the peristaltic pump, the motor...

PREVENTIVE ACTIONS:

To avoid risks the analyzer's moving parts have been designed, built and located in an enclosure with a special key. When present inside the enclosure, these parts have protection covers to avoid any contact and physical injuries to users.

HAZARD: Hazard of burns and poisoning caused by contact with dangerous chemicals

PREVENTIVE ACTIONS:

To avoid risks, the analyzer's parts that can cause contact with chemicals have been designed, built and located in closed enclosure with a special opening key. Before servicing the liquids section, read the material safety data sheets supplied with each chemical to take all the necessary precautions when handling. Wear eye protections, gloves, mask and protective clothing if necessary.

HAZARD: Hazard of poisoning caused by waste gas leaking from the hydraulic parts or waste collector.

PREVENTIVE ACTIONS:

Install the analyzer in location of adequate dimensions and in a well ventilated area.

HAZARD: Hazard of electric shock and/or electrocution inside the electrical enclosure.

PREVENTIVE ACTIONS:

The analyzer's electric equipment complies with EN 60204 requirements.

To avoid risks, the analyzer's parts that can cause hazard of electric shock and/or electrocution have been designed, built and located in an enclosure with a special key. When working inside the enclosure, these parts have protective covers and warning labels to avoid any contact and serious injuries or death to users.

Note:

Electrical equipment, input power and grounding must comply with all national and local regulations and laws.

Check that the source voltage to be used corresponds with that requested by the analyzer.

Check periodically the power cord as well as the analyzer grounding.

1.1.6.3 Chemical and waste gas hazards

The analyzer has been designed, built and equipped to avoid risks caused by physical and chemical factors such as noise, vibrations, radiations, dust, waste gas etc.

2.0 INTRODUCTION – Analyzer Description

This manual provides general information regarding the principles of operation, the proper installation and operation of the CA-6 Analyzer. The Model CA-6 is an on-line sequential sampling analyzer (a sequence of sampling, analysis and result processing), using colorimetric methods. The analyzer is assembled with two separated sections with two lockable doors. The bottom section is the LIQUIDS section. It includes all of the components involved in the flow, mixing and reaction stages of the sample and reagents (sampling pump, colorimetric reaction cell, reagents micro pumps,..). Numerous analysis configurations can be programmed, depending on accessories and of the number of micro pumps mounted in the Liquid Section. The top section is the ELECTRICAL enclosure. It includes the main power supply, the controller PCB assembly and the touch screen interface.



2.1 Applications

The measurement is a colorimetric analysis using an LED light source and a heated colorimetric cell designed for measuring trace amounts of analyte in water.

2.2 Working principle: Lambert-Beer law

A colorimetric determination is based on the color formation of a solution after the addition of reagents. The Absorbance of the solution is measured at a specific wavelength and is related to sample concentration according to 'Beer's law'.

Lambert–Beer law is an empirical relationship relating the absorption of light to the properties of the material through which the light is travelling.

The law states there is a logarithmic dependence between the transmission (transmissivity), T , of light through a substance and the product of the absorption coefficient of the substance, α , and the distance the light travels through the material (i.e. the path length), l .

The transmission (or transmissivity) is expressed: $T = I_1 / I_0$

Absorbance for liquids is defined as the negative logarithm of the transmittance:

$$A = -\log_{10}T = \log_{10}1/T = \log_{10}I_0/I_1$$

I_0 : light intensity through the sample before colorimetric reaction

I_1 : light intensity through the sample after colorimetric reaction

In most cases the absorbance has a linear correlation to sample concentration so a calibration line just requires a zero and span value.

(Zero analyte concentration and the maximum expected concentration) are needed. Multiple analysis of the standard are averaged to gain a reliable calibration line. (See section 8.7)

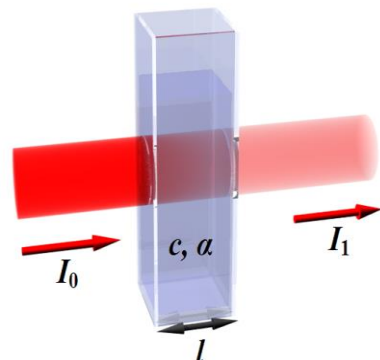

Typical absorbance values range from 0 to 1, but it can be greater than 1.

When the absorbance is 0 then none of the light passing through the sample is absorbed. The intensities of the sample and reference beam are both the same, so the ratio I_0/I_1 is 1. \log_{10} of 1 is zero.

An absorbance of 1 happens when 90% of the light at that wavelength has been absorbed - which means that the intensity is 10% of the blank sample reading.

In that case, I_0/I_1 is $100/10 = 10$ and $\log_{10}(10) = 1$.

2.2.1 Absorption photometry (Colorimetry):

The methods used are based on the formation of a colored complex of the analyte with a color reagent. Light with a specific wavelength is transmitted through the reaction mixture. The absorbance of light by the formed complex is measured by a photometer and related to the concentration of the analyte.

Fig. 2-2: Color development

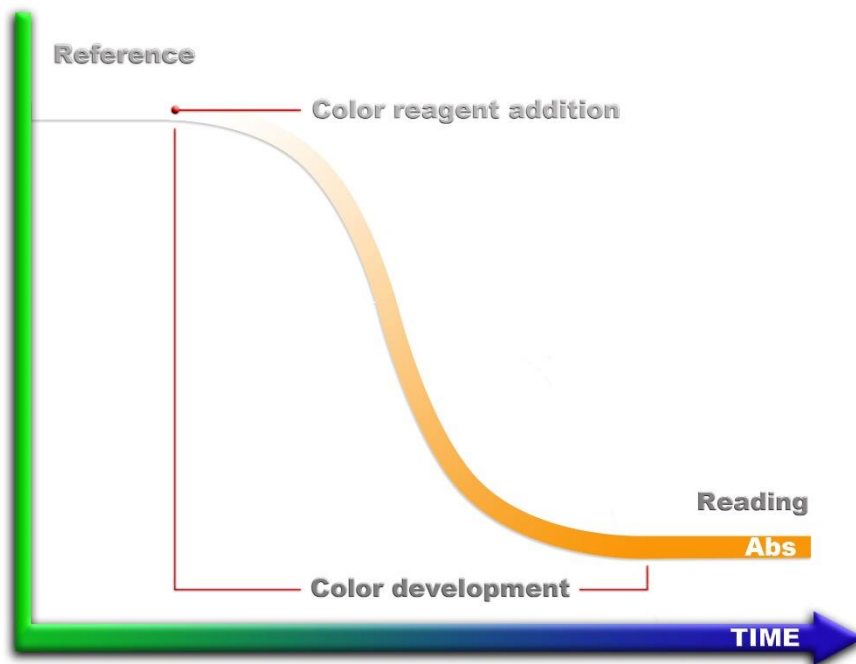

$$\text{Absorbance} = \log (\text{reference} / \text{sensor reading})$$

The DISPLAY screen of the CA6 displays the live Sensor reading, the recorded Reference reading, the recorded sensor Reading, the Absorbance and the Blank (the absorbance through deionized water).

2.3 Analysis Cycle

A typical Analysis Program in the Model CA-6 would have the following structure: Rinse the colorimetric reaction cell and take a sample, add one or more reagents like a buffer or masking agent and then make the first measurement, the reference measurement. The reference measurement eliminates interfering factors such as sample color and turbidity, miscellaneous color from the reagents and refractive index variations.

After the reference reading, the color producing reagents are added. The sample is mixed and allowed time to complete the color forming reactions before taking the second measurement, **the Reading measurement**. The reference and reading values are used to calculate the concentration using the calibration factor. The reaction cell is drained and rinsed several times before starting the next measurement.

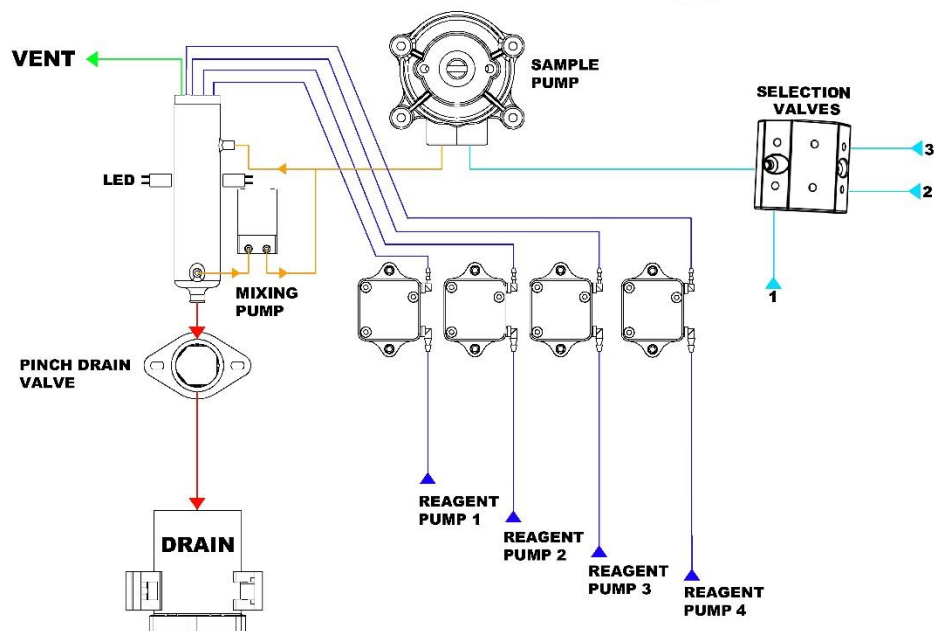

Fig. 2-3 Flow diagram

2.3.1 Typical Run Sequence:

Conditioning, rinsing and sampling

Drain, rinse and sample functions

First the cuvette is drained and rinsed (these steps can also be programmed at the end of the run). The hydraulic lines and the colorimetric cell are rinsed prior to taking the actual sample. Then the sample is taken.

Addition of reagent(s)

Add reagent function

Depending on the method one or more reagents are added before the reference reading.

Mixing and wait

Mix and wait functions

The mixing pump is activated and the liquid is pumped from the lower part to the upper part of the colorimetric cell. The waiting time is programmed in order to eliminate bubbles and allow suspensions to settle ...

First measurement <i>Reference function</i>	Measures the light intensity for the base reference value, in order to start from a fixed reference point and eliminate interfering factors (sample turbidity, color...).
Addition of color reagent(s) <i>Add reagent function</i>	Depending on the method one or more reagents may be added for the color development.
Mixing and wait <i>Mix and wait functions</i>	The mixing pump is activated and liquid is pumped from the lower part to the upper part of the colorimetric cell; mixing the sample and the reagent(s). The waiting time is programmed to provide adequate time to complete the colorimetric reaction.
Reading, absorbance and concentration calculation <i>Absorbance and Calculation</i>	Reading of the light intensity after the colorimetric reaction, calculation of the absorbance and of the concentration.
Drain, conditioning, rinsing, sampling <i>Drain, rinse and sample functions</i>	Drain and rinse of the hydraulic lines and the colorimetric cell.
Waiting time (analysis frequency) <i>Wait function</i>	The wait function allows the frequency of the analysis to set.

2.3.2 Settings

Analysis cycle – Extra cycle (second level password, administration)

These menus list the sequence of programmable operations run by the analyzer. Both the Analysis Cycle and the Extra Cycle menus have 30 programmable steps. Each step has an operation and a time associated with it. The time of the operation is in seconds and the maximum programmable value is 900 seconds. See the list of operations on the following pages. The operations of absorbance, calculation, calibration, validation, blank and print require only few seconds, 1-2 seconds each.

The modular design and easily programmed operations make it possible to automate most any colorimetric laboratory method with up to 4 reagents.

2.3.3 Programmable Functions

Rinse #1

Rinse 1

Rinse #1 opens the bottom pinch valve and Sample #1 flows directly to the drain. The rinsing time is set in seconds.

RINSE #1 = left side of the selection valve

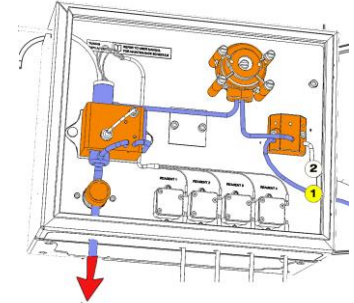

Rinse #2

Rinse 2

Rinse #2 opens the bottom pinch valve and Sample #2 flows directly to the drain. The rinsing time is set in seconds.

RINSE #2 = right side of the selection valve

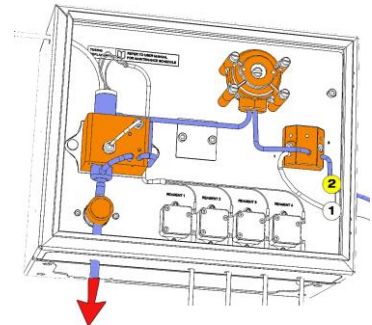

Drain

Drain

Drain opens the bottom pinch valve, drains colorimetric cell and mixer. The drain time is set in seconds.

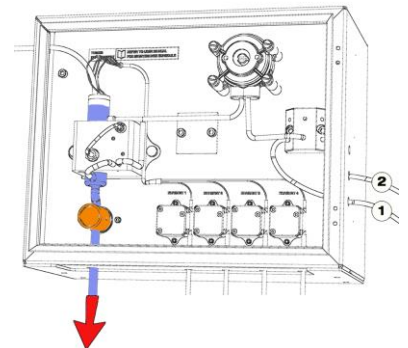

Sample #1

Sample #1 actuates the peristaltic pump with the bottom pinch valve closed and the colorimetric cell fills with sample #1. The sample time is set in seconds.

SAMPLE #1 = left side of the selection valve

Sample 1

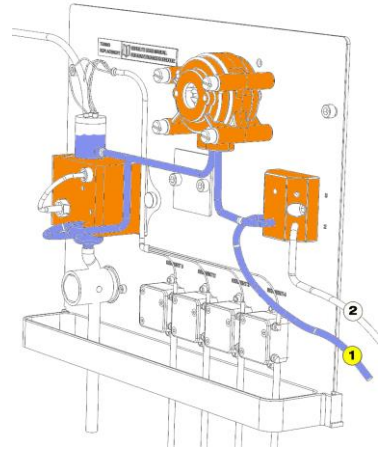

Sample #2

Sample #2 actuates the peristaltic pump with the bottom pinch valve closed and the colorimetric cell fills with sample #2. The sample time is set in seconds.

SAMPLE #2 = right side of the selection valve

Sample 2

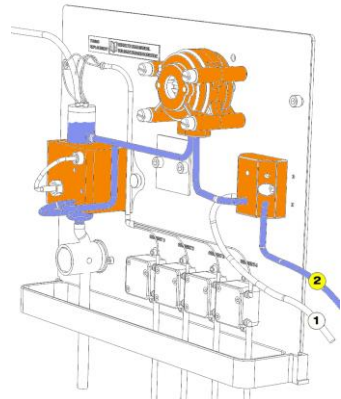

Dilution options

Loop On

Loop On allows the sample liquid (sample line #1) that is to be diluted to flow through the *Sample Loop*. The Loop On time is set in seconds.

Loop off

Loop Off traps the sample inside the loop tubing while the sample fluid is flushed from the lines with the dilution water. The Loop off time is set in seconds.

Loop On

Loop On for the dilution fluid, DI water (sample line #2), dilutes the sample in the loop tube and fills the Colorimetric Cell.

Aux on

Aux On activates an optional auxiliary operation (a digestion, oxidation or auto-function for a dilution configuration). The picture shows the oxidation option (On switches the UV lamp on).

Aux off

Aux Off stops the optional auxiliary operation.

Add rea #1

Add rea #1 turns on the micro peristaltic pump for the addition of reagent #1. The mixing pump is circulating the sample as the reagent is being added. The Add Rea #1 time is set in seconds.

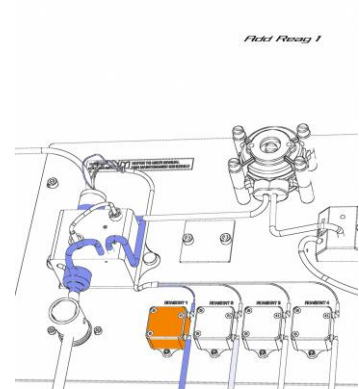
**Add rea #2**

Add rea #2 turns on the micro peristaltic pump for the addition of reagent #2. The mixing pump is circulating the sample as the reagent is being added. The Add Rea #2 time is set in seconds.

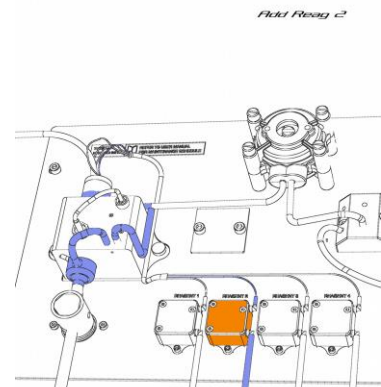

Add rea #3

Add rea #3 turns on the micro peristaltic pump for the addition of reagent #3. The mixing pump is circulating the sample as the reagent is being added. The Add Rea #3 time is set in seconds.

Add rea #4

Add rea #4 turns on the micro peristaltic pump for the addition of reagent #4. The mixing pump is circulating the sample as the reagent is being added. The Add Rea #4 time is set in seconds.

Wait

The waiting time is set in seconds. Wait puts the CA6 in Stand By mode.

Mix

The mixing time is set in seconds.

Reference

The reference measurement is the first point for the calculation of the absorbance, I_0 . Reference sets the time, in seconds, of when to take the base intensity measurement.

Absorbance

Absorbance sets the time, in seconds, of when to take the colored intensity measurement, the Reading, I_1 , and calculate the absorbance, I_0/I_1 . Typically 1 – 2 seconds

Calculation

Calculation sets the time in seconds to convert the absorbance reading into a concentration reading and sends the calculated value to the main display. Calculation uses the absorbance reading and the calibration factor. Typically 1 – 2 seconds

Calibration

Calibration sets the time in seconds, to calculate and record a new calibration factor after a calibration extra cycle, Auto Calibration. Typically 1 – 2 seconds

Validation

Validation sets the time, in seconds, to calculate and display % Validation of a Known Standard in the display screen using the current calibration factor as a calibration check. A 5 ppm sample reading 4.8 ppm, displays 96% after the validation extra cycle. Typically 1 – 2 seconds

Blank

The Blank function sets the time, in seconds, to enter a new blank calibration, calculating and recording the new blank value in the calibration screen after a Blank extra cycle. Typically 1 – 2 seconds

Save Dtlog

Allows the measurement's reading to be saved in the internal Data logger, Typically 1 – 2 seconds, the data log register is only written to after the internal 24 hour clock resets to 00:00:00

Relay #1

The Relay #1 setting allows a time, in seconds, to be assigned to the activation of relay 1. The relay configuration is set in the Service Menu.

Relay #2

The Relay #2 setting allows a time, in seconds, to be assigned to the activation of relay 2. The relay configuration is set in the Service Menu.

2.4 Components

The CA-6 Analyzer has three distinct sections:

1. The **Liquids Section** which includes all of the liquid handling equipment. This is located in the Lower Compartment, (pictured right, with Dilution Module).
2. The **Electrical Section** including power supply, microprocessor controller, I/O and touch screen interface are located in the Upper Compartment.
3. **Reagents Section**, the CA-6 can use up to 4 reagents, these containers are typically stored below or beside the analyzer.

2.4.1 Fast-loop reservoir

The external Fast-Loop Reservoir is a sample collection and conditioning chamber for a sample coming from a pressurized line or from the optional filtration unit. The overflow design removes variations in sample line pressure as well as eliminating any air bubbles from the sample line or bubbles generated by the cleaning cycle of the optional filtration unit. Inside the fast-loop reservoir the sample is at atmospheric pressure and this allows the sample pump to provide a consistent sample delivery to the colorimetric cell. In addition, the fast-loop reservoir provides an extra quantity of sample in case of an interruption in the sample flow.

The stainless steel drain tubing keeps a constant sample level inside the container. The sample flow should be adjusted for a continuous sample overflow through the stainless steel drain tube thereby providing ample circulation to avoid suspended solids accumulation in the reservoir. A small hole at the top of the stainless steel drain tubing allows the fast-loop reservoir to be easily emptied for cleaning purposes.

The Fast-Loop reservoir uses a level sensor to verify sample volume. The loss of sample triggers the level switch which places the analyzer in stand-by mode at the end of the current measurement cycle. When the sample flow returns and refills the reservoir, the analyzer will automatically start a new cycle.

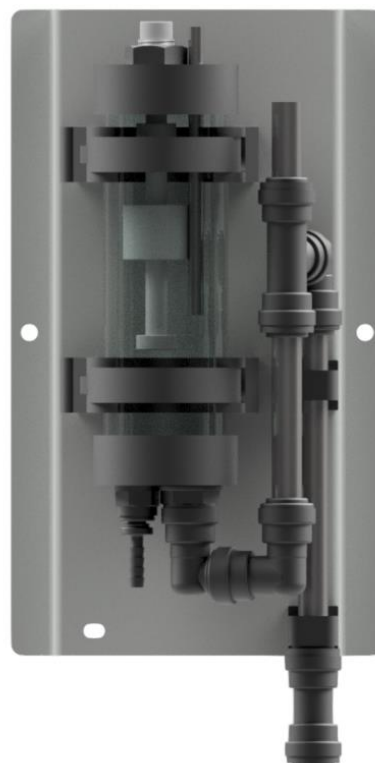

2.4.2 Sampling Pump

Model CA-6 uses a Masterflex® peristaltic pump for sampling. The Model # of the pump is printed on the cover and the Model # includes the two digit tubing size designator. Proper diameter and material of the tubing must be used for proper functioning of the CA-6 Analyzer, use only ECDA replacement tubing and parts. The pump is located in the liquid enclosure.

2.4.3 3 Way Valve

The use of 3 Way Valves allows the CA-6 to perform automatic operations. An operator can set up auto-calibration, auto-validation or auto-cleaning functions. The valve is located in the liquid enclosure.

2.4.4 Micro Peristaltic Pumps

The reagents are dispensed with “Micro Peristaltic Pumps”. Up to 4 pumps can be installed in the analyzer, allowing the use of up to 4 different reagents. Every 1 second pulse of the pump allows a 0.05 ml dose of reagent. The pumps are located in the liquid enclosure.

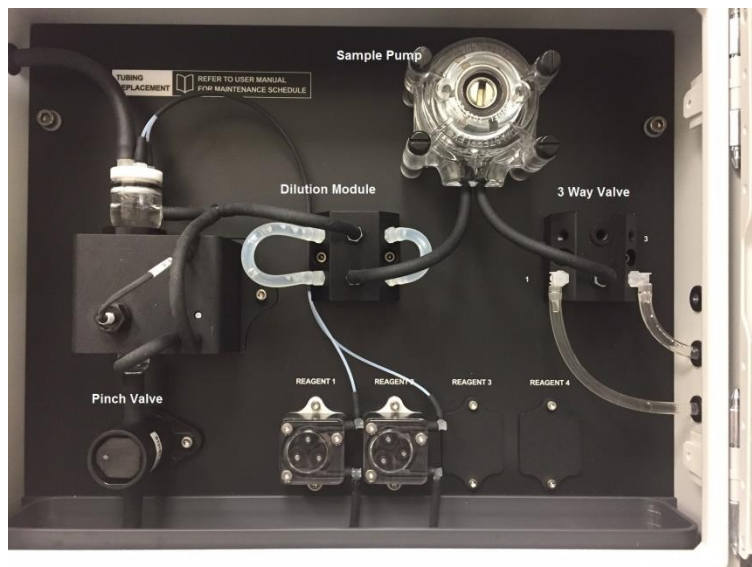

2.4.5 Mixing Pump

The sample and reagents are mixed with a diaphragm pump. The liquids are pumped from the lower part of the colorimetric cell to the upper part for a specified period of time. Flow direction (inlet / outlet) of the pump is indicated with the symbols (V) and (Λ) on the pump body. The mixing pump is located in the heater block incasing.

2.4.6 Pinch Valve

The normally-closed pinch valve is used to control the draining or rinsing of the colorimetric cell. When the valve is actuated it opens and drains the cell. The valve can be manually actuated by pressing the black plastic face. The pinching jaws are sized for 3/8" O.D. Silicon or Viton tubing. The size and material of the tubing is VERY IMPORTANT, use only ECDA spares. The pinch valve is located in the liquid enclosure. This tubing should be checked regularly for proper sealing.

2.4.7 Colorimetric Reaction Cell

The colorimetric reaction cell is made of glass with a diameter of 16 or 26 mm, depending on the measured parameter. The cell is located inside a thermostatic block. You can easily slide out the cell by first taking off the tubing around the cell, twist then pulling the cell straight up. The 16 mm cell comes with two halves of a black sleeve adapter held together with an O-ring.



IMPORTANT: The sleeve adapter is made with apertures to focus the light path through the cell. Make sure that the light pathway is aligned with these apertures for the unit to work properly. This can be done by twisting the sleeve and aligning its creases with a small white dot on the top of the heater block. When the pathway is aligned correctly, the display READING will be greater than 0. We have added additional white dots on the sleeve adapter and on the top of the heater block so that it is easier to align.

2.4.8 Sample Drain

Tubing for the sample drain maintains a constant level of few cm of liquid in the colorimetric cell.

2.4.9 Electronic Components

The microprocessor based controller and its PCB assembly are located in the electronic section. The cover and touch screen interface have been removed to show the internal construction. The controller handles all analyzer operations. It collects all the information and data coming from the different analyzer devices and controls all I/O dialogue with the user touch screen interface and data transfer equipment. **Remove the cover to adjust the REFERENCE LED voltage. This adjustment should only be made when a CLEAN reaction cell filled with deionized water reads below 8. Turn the potentiometer clockwise to increase the REFERENCE value to 9.00 ± 05 .**

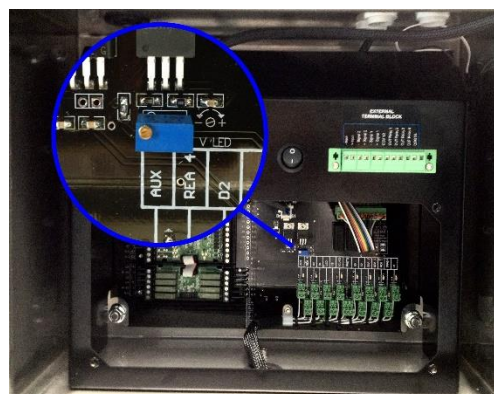

3.0 OPTIONS

Two popular options are the Dilution Module, allowing over range samples to be diluted into the proper measurement range and the Oxidation Module, used to break down complex molecules into measurable constituents.

3.1 Dilution Module

For high range samples a dilution module is added to the hydraulic configuration. A second 3-way valve is added to the flow train. The Loop On and Loop Off functions are used to program the steps of the dilution. Below is a description of the steps of the dilution.

Sample and DI water must be connected to the correct position, verify: #1 (sample) connected to the left side of the selection valve and #2 (deionized water) to the right side of the selection valve.

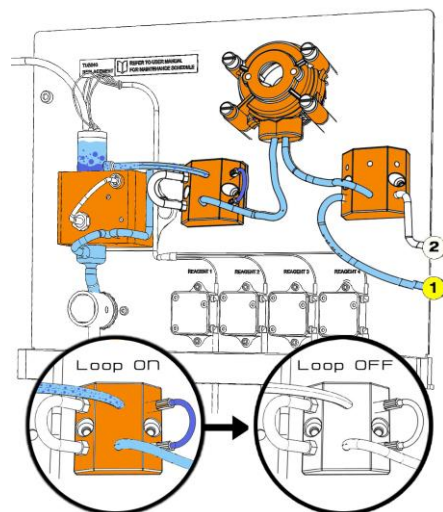

1) Drain function

The first step of every measurement cycle is a drain cycle. This function opens the pinch valve to empty the colorimetric cell.

2) Rinse Function #1 or #2 Loop On/Loop Off

With Loop On, the loop pathway is open and the sample passes through the loop and the hydraulic lines to drain.

With Loop Off, the loop pathway is closed trapping a small sample in the loop while the sample passes through the other side of the valve to drain.

This function also allows the loop to be filled with the sample and then to trap and hold the exact quantity of sample to be diluted.

The "Rinse 1" picture shows rinse function with sample connected to #1 and loop on.

The "Rinse 2" picture shows rinse function with DI water connected to #2 and loop on.

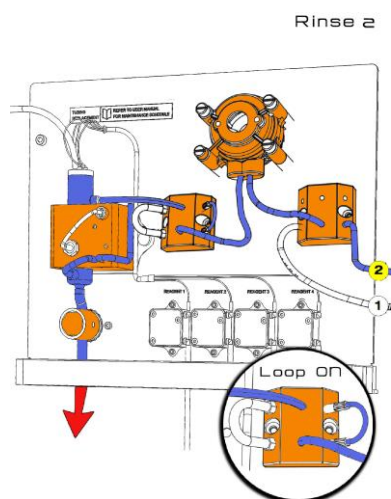
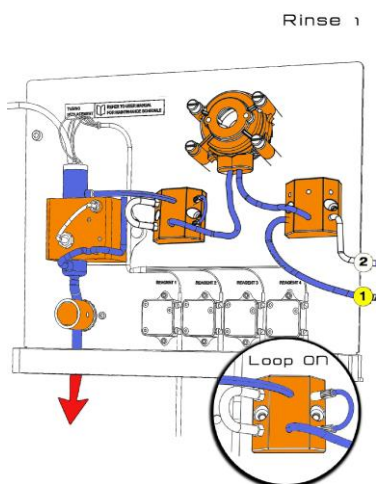

3) Sample Function #1 or #2 Loop Off / Loop On

With the Sampling function, the sample pump is activated and the pinch valve (to drain) is closed. De-ionized water (#1) is used to fill the colorimetric cell after passing through the loop.

Loop On, the loop pathway is open. This releases the sample contained inside the loop to mix with the DI water (#1) passing through the loop, In this way the sample quantity trapped in the loop during the Rinse Cycle is mixed with DI water and transferred to the colorimetric cell for the colorimetric analysis.

Loop Off, the loop pathway is closed and liquid does not pass through the loop. Sample 1 picture shows the sample function with sample connected to #1 and loop on or off.

After the dilution, the colorimetric reaction is performed.

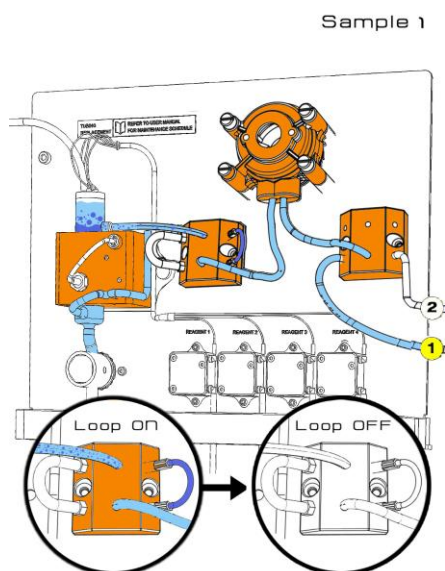



3.2 Oxidation/Digestion Module

For the detection of some parameters (for example TP) it is necessary to perform a photochemical oxidation or digestion before the colorimetric reaction. In these cases the Oxidation Module option is added to the Liquids section.

To ensure a complete oxidation of the sample, the oxidation can be performed using sulfuric acid, heat, UV irradiation and/or a chemical oxidizer.

DANGER!

Below is a list of possible hazards to be considered when the oxidation / digestion module is included in a CA-6 analyzer:

	<p>Hazard of chemical burns</p> <p>This symbol is used to represent the hazard of severe burns and serious injury from handling dangerous chemicals. All handling and maintenance operations on chemicals labeled with this symbol should be made by qualified personnel in accordance with national or local regulations. Qualified Personnel means a person who has been fully trained and has professional experience to avoid chemical hazards and dangers. Before handling these chemicals or proceeding with service operations, read the material safety data sheets supplied with each chemical to take all the necessary precautions when handling.</p>
	<p>Hazard of UV radiation</p> <p>This symbol is used to represents a hazard from ultraviolet radiation. It is mandatory to wear eye protection when operating or servicing UV lamps labeled with this symbol.</p> <p>Never look directly at a lighted UV lamp. UV radiation exposure can cause severe and permanent damage to skin and eyes.</p>
	<p>Hazard of hot surface</p> <p>This symbol is used to present a hazard from hot surfaces.</p> <p>Do not touch the oxidation / digestion module during operation.</p>

Method Description:

After rinsing the hydraulic line, the sample is pumped with the peristaltic pump into the reaction cell.

The oxidation can be performed with:

- the addition of a chemical oxidizer (for example sodium persulfate or potassium peroxodisulfate) using the Micro Peristaltic Pump
- the addition of sulfuric acid, using a Micro Peristaltic Pump
- UV irradiation (photochemical)
- heating the cell

The sample and reagents are mixed using the diaphragm pump until the oxidation cycle is complete.

After the oxidation, the colorimetric reaction is performed to measure the concentration of the specific parameter present in the sample.

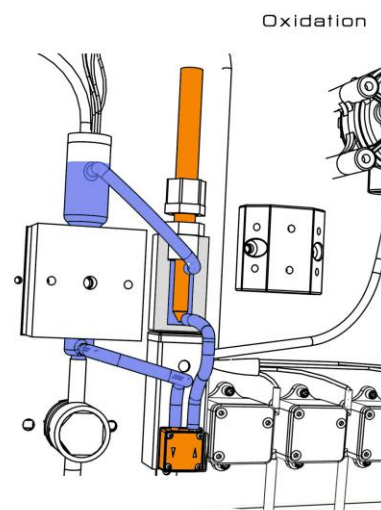

4.0 INSTALLATION

4.1 Unpacking and Inspecting

The CA-6 Analyzer is fully assembled and was tested for proper performance at the factory before packaging and shipping. Before proceeding with installation of the analyzer, it is recommended that you carefully inspect the box and analyzer for damage that may have occurred during shipping.

Use care when unpacking and moving the analyzer. Refer to the Packing List when unpacking the CA-6 Analyzer and be careful not to misplace any of the accessories.

4.2 Analyzer Handling

Use extreme care when lifting or moving the analyzer. If the analyzer has been in service, empty all liquids from the hydraulic parts before moving the analyzer.

4.3 Location and Mounting Instructions

Install the CA-6 Analyzer in a clean, dry and dust free environment or in an enclosure with good ventilation.

Environmental Operating conditions are:

- Temperature: 5° to 45°C (41° - 113°F)
- Relative humidity: 80% maximum

If the temperature is below 5°C (41°F), the analyzer should be installed in a heated cabinet. Optional fridge for chemicals for high temperatures

Due to the possible generation of chemical or waste gases, choose a well ventilated location for the analyzer.

The Model CA-6 analyzer is supplied with four mounting brackets for wall mounting or stainless steel support rack installation. To Wall or Rack mount the CA6 analyzer use (4) ¼-20 screws or larger. The Reagent bottles are supplied with the analyzer. The relative position of the reagent bottle(s) to the reagent pump(s) is very important. The maximum distance between the bottom of the reagent bottle(s) and the lowest edge of the analyzer panel shall be no more than 40 cm (15.75”).

4.4 Pre-Installation

Considerations for the proper Location of the CA-6 Analyzer:

- Place the analyzer close to the sample point in order to minimize the response time.
- The sample point should provide a homogenous and representative sample to the CA6.
- Plumb sample line to analyzer. If the sample line is under pressure use an adjustable shut-off valve (needle or ball valve) to feed the Fast Flow Reservoir. If drawing from a tank or pond then minimize the tubing length. If longer than 10 feet add time to the initial Rinse times in the Analysis Cycle and the Extra Cycle. (+5 seconds per 10 ft section)
- Position the CA-6 Analyzer near a suitable drain, with sufficient capacity to handle the gravity

fed waste discharge and the bypass overflow from the Fast Loop Reservoir (if used).

- **WARNING: The sample drain from the analyzer must drain at ambient pressure with no restrictions or counter pressure.**
- Clearance requirements for the analyzer should be 8 inches (20 cm) on either side of the analyzer and 40 inches (100 cm) on the front.
- Sufficient space for the reagent containers should be provided beside or beneath the analyzer.
- The reagent containers should be placed in a suitable collection basin in case of spills.
Note: 15.75" maximum height between the reagent's bottle(s) and the reagent's pump(s).

4.5 Electrical Connections

4.5.1 General information

The electrical installation should be carried out by qualified personnel in accordance with all national and local regulations. Qualified Personnel refers to a person who has the professional training and experience to avoid electrical hazards and dangers.

Only Qualified Personnel should have access to the key that opens the analyzer enclosure.

Power to the CA-6 Analyzer should be routed through an ON/OFF switch.

Turn off the power before beginning any service on the CA-6 Analyzer.

The CA-6 must be properly grounded to prevent the possibility of electrical shock. All metal surfaces are connected to the Ground terminal. The Grounding Terminal/Screw is located inside the electrical enclosure in the upper left position.



It is the user's responsibility to periodically check the efficacy of analyzer's electrical ground.



The analyzer stops when power is lost or disrupted and automatically restarts when the power is restored.



Users and qualified maintenance personnel must proceed as follows:

- Always turn off the power before servicing the analyzer
- Take notice of all Electrical Shock and/or Electrocutions labels placed on the analyzer



DANGER:

No Service should be carried out on the instrument without first switching off the power.

4.5.2 AC Power Connections

The CA-6 Analyzer is designed for operation with 110-220Vac, 50-60 Hz power. The supplied AC power cord exits through a port on the top side of the electrical compartment. All the connections must be made in accordance with national or local regulations. The analyzer is equipped with an internal power switch (main power switch). It is recommended that the CA-6 analyzer is connected to power via a circuit breaker or an ON/OFF switch installed near the unit.

4.5.3 Signal Output Connections – TB (4-20 mA, alarm, aux, Modbus TCP/IP, Modbus RS485)

- A digital input (- Input + Input) for remote start and stop. This function gives the possibility to remotely operate the process analyzer, i.e. START and STOP running.
- (1) 4-20 mA output (-signal 1 / + signal 1) the second 4-20 mA output (-I signal 2 + I signal 2) is available only for dual channels analyzers, optional for single channel analyzers.
- (4) configurable relays (Normally Open Relays)

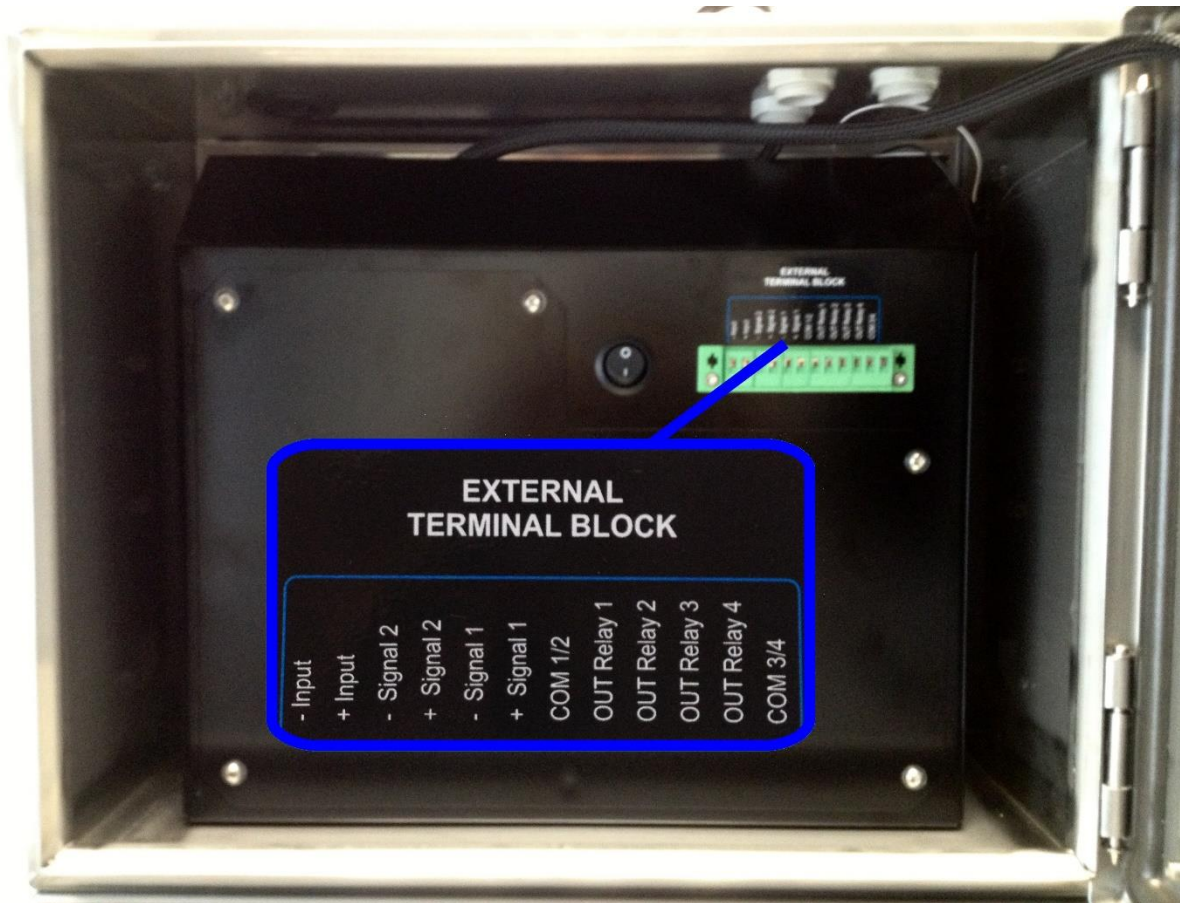

Modbus TCP/IP Data. Connect the Analyzer to a physical network by plugging a network cable into the RJ45 jack located on the top of the enclosure. Default configuration is DHCP ON and may be changed using the analyzer configuration menus. Access the ADMIN account and select SERVICE. Located at the top-right of the screen, just to the left of the window close “X” is a hidden button. Pressing this enables access to the Ethernet configuration menu. Enter the static IP address and network configuration data <or> read IP address obtained via DHCP. From another network device use the PING command to verify connection to the DHCP address or static IP. If PING indicates data loss, swap the network cable for a cross-over style and retry. Once PING indicates a valid physical connection data may be accessed and formatted using the table below.

Modbus RTU TCP/IP		
Jack	RJ45 located on the top enclosure	
Connection	TCP/IP port 8000	
Network	DCHP (default) or Static IP	
Protocol	Modbus RTU	
Slave ID	01	
Function Code	03,04 Read	
Analyzer Values		
Address (Decimal)	Format (little-endian byte swap)	Scale Factor
900	32-bit float (CD-AB)	Result CH1 in PPM
902	32-bit float (CD-AB)	Result CH2 in PPM
904	32-bit float (CD-AB)	Validation %
906	32-bit float (CD-AB)	Calibration Factor
908	32-bit float (CD-AB)	Reagent 1 level %
910	32-bit float (CD-AB)	Reagent 2 level %
912	32-bit float (CD-AB)	Reagent 3 level %
914	32-bit float (CD-AB)	Reagent 4 level %

MODBUS RTU CONNECTION COLORIMETERS

RS 485 – 2W SETTINGS		
Baud Rate	9600	
Data bits	8	
Parity	E	
Stop bit	1	
Analyser I.D. (slave , node number)	Last 2 number of the analyzer's serial number (example: s/nCL345 = I.D. no. 45)	
ANALYSER'S VALUES		
Address	format	alias
900	32-bits float (CD-AB)	result CH1
902	32-bits float (CD-AB)	result CH2
904	32-bits float (CD-AB)	Validation %
906	32-bits float (CD-AB)	Calibration factor
908	32-bits float (CD-AB)	Reagent 1 level %
910	32-bits float (CD-AB)	Reagent 2 level %
912	32-bits float (CD-AB)	Reagent 3 level %
914	32-bits float (CD-AB)	Reagent 4 level %
ANALYSER'S STATUS		
800	bit	"online" condition
801	bit	single cycle running
802	bit	"stopped" condition
803	bit	extra cycle running
804	bit	Sample 1 running (dual streams only)
805	bit	Sample 2 running (dual streams only)
806	bit	loss of sample 1
807	bit	loss of sample 2
808	bit	reference low alarm
809	bit	calibration alarm

Modbus protocol connection (Modbus RTU). This module is plugged on the control board. Use the connector provided on the board for communication.

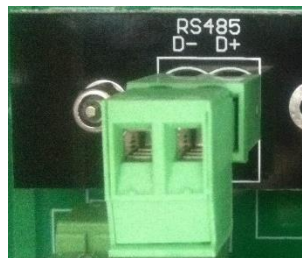

5.0 REAGENTS PREPARATION

Each analyte uses its own set of reagents to develop the distinctive color for measurement.

Use good laboratory technique. Wear safety goggles, gloves and protective clothing when preparing the reagents, calibration solutions or cleaning solutions.

Mind all Hazard and Poison labels

Pre-made reagents and solutions are available from ECDA. Please contact the factory or your regional distributor for more information. Several of the reagents are listed as Hazardous Shipping Materials; these materials are only available for shipment domestically inside the USA.



Before proceeding with the analyzer Start-Up, check that all installation (Section 4.0) operations have been properly completed. Please verify that all suggestions and recommendations have been followed.

6.0 ANALYZER INITIAL START-UP

- Open The Liquids Compartment
- Remove the block from the **Drain Pinch Valve** by pressing the black button. Save for future use. It removes compression from the drain tube when the CA6 is not in use.
- Install the Fast Loop Reservoir(s) close to the right side of the CA-6 Analyzer. Samples and Dilution water must be drawn from atmospheric pressure.



6.1 Sample and Drain Tubing Connections

After double checking Sections 4.0 & 5.0, proceed as follows:

- Connect the overflow drain of the Fast-Loop Reservoir(s) to the drain with 12 mm OD tubing.
- Connect the sample feed line (or the outlet of the optional filtering unit) to the bottom of the Fast-Loop Reservoir previously installed on the right side of the analyzer.
- Connect the sample inlet tubing from the analyzer, Sample #1, to the “Sample to Analyzer” port fitting on top of the Fast-loop Reservoir. The John Guest fitting accepts 1/8” I.D. flexible tubing (Tygon, Pharmed or Norprene are recommended). The sample will now be taken from atmospheric pressure by the sample peristaltic pump.
- Connect the reagents tubing (coming from the reagent bottle) to the corresponding REAGENT port fitting (Reagent 1 to Port 1) using 1/16” I.D. flexible tubing (Tygon, Pharmed or Norprene are recommended). The reagents will be delivered to the optical cell by the internal reagent peristaltic pumps. Note the maximum height of 15.75” (40 cm) between the bottom of the bottle(s) and the bottom edge of the analyzer panel. Repeat for additional Reagents as required.
- Connect the analyzer drains (CELL and VENT DRAINS) to a waste line using 3/8” flexible tubing.



Figure 6.01: Fast Loop Reservoir

- **WARNING: the drain from the analyzer must be at atmospheric pressure with no restrictions.** The drain line should be properly sized to accommodate the overflow coming from external fast-loop reservoir and the gravity fed analyzed sample.
- Check sample level in the Fast-Loop Reservoir, if used, and adjust the sample flow rate to allow a continuous overflow to the drain line.
- Connect float valve switch from the Fast Flow



reservoir to the connection on the upper right side of the CA6.

6.2 Powering, Priming and Starting the Analyzer

- Supply power to the analyzer. Turn ON Power Switch. The Main Menu will appear on the display.
- Login with the 1st level password, SERVICE (1111).
- Press the DISPLAY button on the touch screen
- Press the MANUAL STEP button. This allows manual control of the functions.
- Select the SAMPLE 1 function, enter 13 seconds Press ON. This starts the sample pump and it runs for 13 seconds filling the optical cell. After filling press and hold the Drain button. Repeat for SAMPLE 2 if present.
- The SAMPLE function fills the colorimetric cell with the sample. Check the optical signal on the chart. With an uncolored sample the red line should be approximately 9 (the reference value) when the optical cell is filled, 4-5 when empty.
- Select the ADD REAG 1 function and enter 30 seconds. This will prime the reagent peristaltic Pump. When primed, reagent will be seen dripping from the feed tube into the optical cell. Repeat with ADD REAG 2, 3, 4 as required.
- Verify the drain tube below the pinch valve is correctly positioned in the drain and is not kinked or bent which would restrict the flow.
- Select the DRAIN function and enter 5 seconds. (Drains cell)
- Select the SAMPLE function and enter 20 (13) seconds. (Fills 16 mm cell with sample)
- Close all the menu windows and start the measurements by pressing the RUN button and then START ONLINE button for continuous on-line operation or choose the Cycle Ch1, Cycle Ch2 or the Extra button for a single analysis cycle.

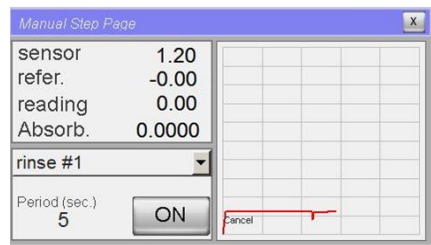
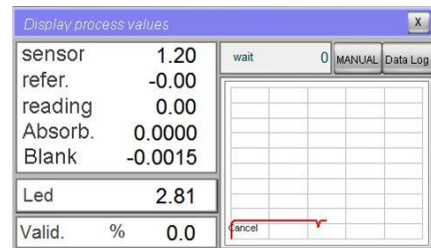
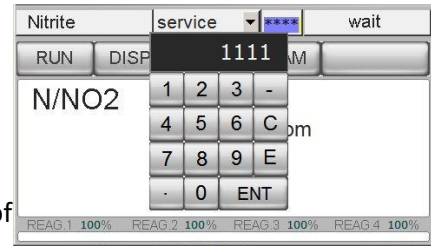

7.0 CALIBRATION

(1st level password SERVICE)

Colorimetry is a relative method and a calibration is needed before quantitative measurements can be performed. This is done using standard solutions and analyzing them in the same way as the samples will be analyzed. To ensure accurate measurements, the analyzer should be calibrated periodically. A Calibration entails two measurement points, a zero point and a slope. The zero point is referred to as *the blank* and is accomplished using distilled or De-Ionized water. The system slope is determined using a standard solution of known concentration.

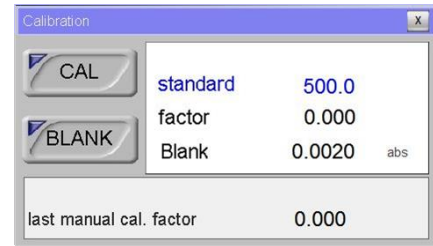

- Blank: Zero point of the system
- Factor: Slope of the system

The calibration can be done manually or automatically.

Initial calibration takes place at the factory. These values should be used on a comparison basis for all subsequent calibrations.

7.1 Blank Calibration (Zero Point)

The Blank calibration should be performed whenever the reagent(s) are replaced and every time a manual calibration is required.

This procedure is for a manually performed blank calibration. (See section 7.3 below for a step by step guide) Before performing a manual calibration the operator should disable the 4-20 mA output. To disable the 4-20 mA output press PROGRAM → SETTINGS → OUTPUT SIGNAL → ENABLE/DISABLE.

- Turn OFF sample flow
- Disconnect the sample #1 tubing from the sample vessel or the fast-loop reservoir,
- Place it in a container of distilled or de-ionized water (500-1000 ml). When the next analysis cycle begins the analyzer will sample the DI water.
- The Blank absorbance detected by the analyzer is assumed to be the absorbance produced by the reagent(s) and De-Ionized water with no ammonia present. This is the BLANK value, the zero concentration point.
- Manually enter the new Blank value in PROGRAM → CALIBRATION MENU by pressing and holding the BLANK key (3-10 seconds) until the value changes. This operation will replace the stored BLANK value. It can only be executed after a completed analysis cycle, with the analyzer in Stand-By (Wait) condition.

It is recommended that **at least three analysis cycles** be run with DI water before proceeding to a new BLANK calibration.

The Blank Calibration can be overwritten in the Service Menu by entering a user determined value. This could be an average of the absorbance values determined by several cycles of deionized water. Place

the sample tube in a gallon of De-ionized water, Press RUN ONLINE. After 1 hour, 5 cycles will be completed. Press RUN, Emergency Stop, RUN, RESET Emergency Stop. The analyzer will be in Standby Mode (WAIT). Press Display, Data log, average the last 3 absorbance values. Enter the average in the Blank window of the Service Menu.

7.2 Slope Calibration (Factor)

Set the value of the standard solution to be used for the calibration by pressing PROGRAM → CALIBRATION MENU → STANDARD, enter the value of the calibration solution.

This procedure is for a manually performed slope calibration (Factor). (See section 7.3 below for a step by step guide)

- Disconnect the sampling tubing from the sample line or fast-loop reservoir (if present),
- Place sample tube into a container of standard solution. When a new analysis cycle begins, the analyzer will sample the standard solution.
- The absorbance detected by the analyzer is assumed as the absorbance produced by the standard solution.
- The stored BLANK value is subtracted from the Standard Solution Absorbance and the factor value is calculated. The FACTOR is manually entered by pressing and holding the CAL key (3-10 seconds) in the CALIBRATION MENU until the FACTOR value changes. This operation will replace the stored FACTOR value. It can only be executed after a completed analysis cycle, with the analyzer in Stand-By (Wait) condition.

It is recommended that **at least three analysis cycles be run** with standard solution before proceeding to a new FACTOR calibration.

The FACTOR Calibration can be overwritten in the Service Menu by entering a user determined value. This could be an average of the absorbance values determined by several cycles of Standard Solution. Place the sample tube in a gallon of Standard Solution, Press RUN ONLINE. After 1 hour, 5 cycles will be completed. Press RUN, Emergency Stop, RUN, RESET Emergency Stop. The analyzer will be in Standby Mode (WAIT). Press Display, Data log, average the last 3 Absorbance values. The Standard Solution value divided by the average absorbance equals the FACTOR. Enter the value in the FACTOR window of the Service 2 Menu. The Service 2 Menu is accessed by pressing $\frac{1}{4}$ " to the left of the Close (X) of the Service 1 Menu.

7.3 Step by Step Manual Calibration

Before performing a manual calibration the operator should disable the 4-20 mA output. To disable the 4-20 mA output press PROGRAM → SETTINGS → OUTPUT SIGNAL → ENABLE/DISABLE.

1. Disconnect the sampling tubing coming from the fast-loop reservoir (if present).
2. With the sampling tube connected to port #1 of the 3 way valve, place the other end in a container of distilled water (500ml – 1000ml). Keep the door Closed during operation.
3. From the Main Menu select RUN → **Cycle Ch 1**.

4. When the analysis cycle begins the analyzer will sample the DI water and automatically run 1 analysis cycle and then stop and enter the Stand-By (Wait) mode. Repeat 2 times.
5. After the third cycle press PROGRAM → CALIBRATION MENU key (Password protected, Service 1111) to open the calibration menu window. Press and hold the BLANK button until the value changes. This operation will replace the stored BLANK value.
6. Remove the sampling tubing from the DI water and place it in the standard solution container.
7. Verify or enter the value of the standard solution used for the calibration by pressing PROGRAM → CALIBRATION MENU → STANDARD.
8. From the main menu select RUN → **Cycle Ch 1**. When the new analysis cycle begins the analyzer will sample the standard solution and automatically run 1 analysis cycle, then stop and enter the Stand-By (Wait) mode. Repeat 2 times.
9. After the third cycle press PROGRAM → CALIBRATION MENU to open the calibration menu window, press and hold the CAL button until the FACTOR value changes. This operation will replace the stored FACTOR value.
10. Remove the sample tube from the standard solution and reconnect the sample tube to the fast-loop reservoir (if present).

After manual calibration enable the 4-20 mA output, pressing PROGRAM → SETTINGS → OUTPUT SIGNAL → ENABLE/DISABLE. Start the sampling cycle by pressing RUN → Start On-Line.

8.0 USER INTERFACE

8.1 Touch Screen Display

The user interface consists of the Touch Screen Display located on the front panel of the analyzer enclosure. All input/output data, information, alarms and fault conditions are shown on the display while all commands and settings may be transferred to the analyzer simply pressing the touch screen. (An example of a typical screen)

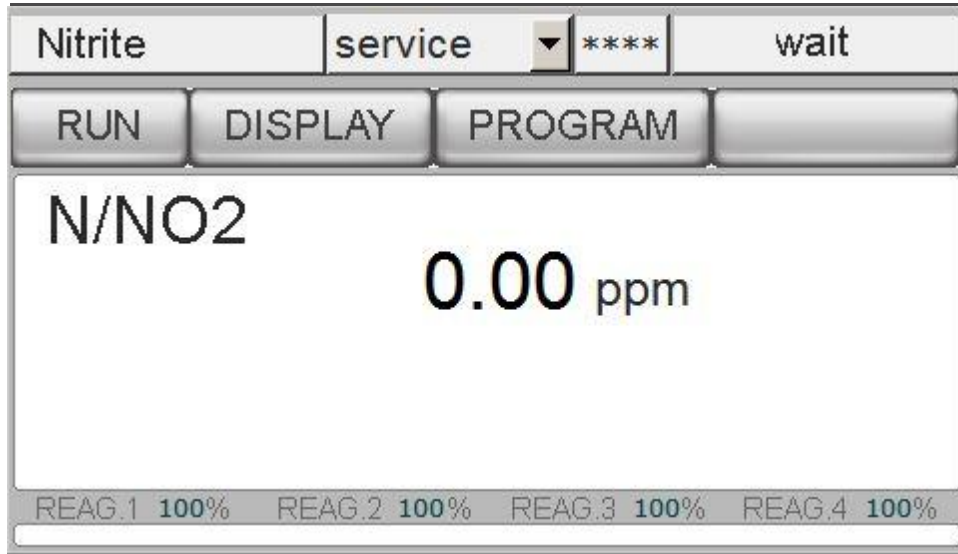

8.2 Passwords (****)

Access to the various menus is password protected. There are three levels of security as described in the table below.

First level password (service): 1111

Second level password (admin.): 6699

No password access	First level password access	Second level password access
Main menu	Display menu – Manual step	Program menu – Analysis cycle
Display menu – Display process values	Program menu – Calibration menu	Program menu – Extra cycle
Program menu - Settings		Service Menu
Help		

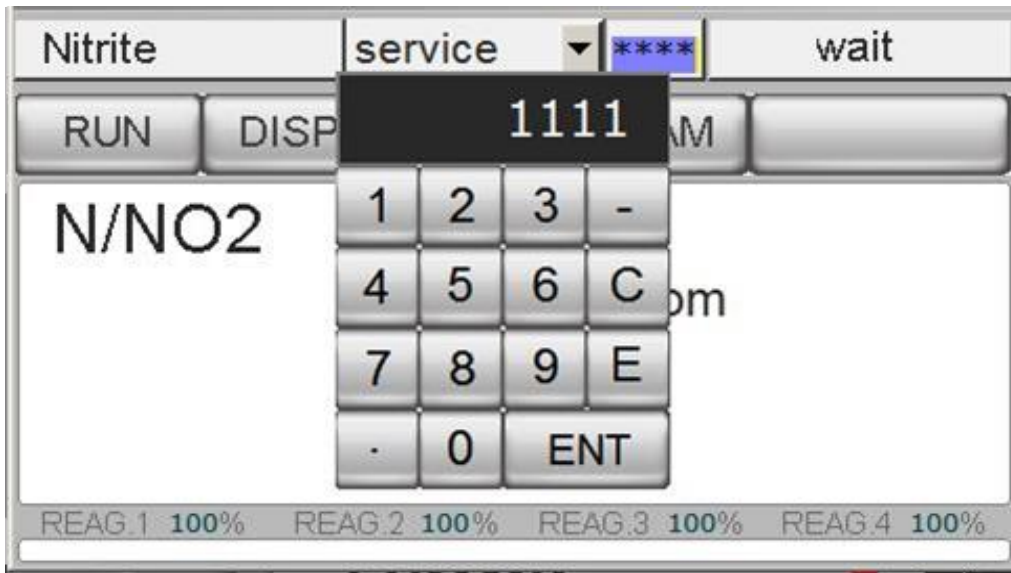

8.3 Main Screen

The main screen displays the analyzer status, the measured parameter, reagent status and provides access to the various Menus.

- **Analyzer type** (read only window) example: Silica Analyzer, Ammonia Analyzer, Nitrite Analyzer, Phosphate Analyzer...
- **Login ****** window (two levels of password); pressing on **** the user can enter the 4 number password
- **Menu Buttons** provide access to the sub-menus Run, Display, Program, Service and (?) Help
- **Measured Value** with engineering units (ppm or ppb) of the last analysis
- **Alarms / Relay status**
- **Current Operation** of the analysis cycle in progress
- **% Reagent Consumed**, if the reagent level goes below 4% value, the analyzer goes in FAULT alarm and stops automatically. **The alarm message will be displayed in the main menu and the FAULT contact will be activated.** Every time the reagent level is restored, it is necessary to reset the value to 100% by pressing the %value of the filled Bottle Reag. 1, 2, 3 or 4 **Filled?** →YES.

8.3.1 Status Modes

ANALYZER OPERATING STATUS	
ON-LINE	The analyzer is performing a continuous set of analysis based on the steps programmed in the Analysis Cycle menu. When the analyzer completes an analysis cycle, it restarts a new analysis. This condition is identified as the ON-LINE condition. The Analysis is started when the START ON LINE? button is pressed.
SINGLE CYCLE	The analyzer performs a set number of analysis cycles. When the cycles have been completed the analyzer will switch to STAND-BY Mode.
STAND-BY (WAIT)	The analysis cycle has stopped and the analyzer is waiting for a command. The analyzer switches to STAND-BY at any forced stop whether manually or fault generated. STAND-BY also occurs at the end of a SINGLE CYCLE.
MANUAL STOP	The analyzer has been forced to stop. A message on the main menu shows "MANUAL STOP" and the associated fault condition. Press RUN and then RESET to return analyzer to stand-by mode (WAIT)

8.3.2 Menu Buttons

MENU ACCESS BUTTONS	
RUN	The RUN Menu provides access to the Start /Stop functions of the analyzer: Start On-Line, Cycles to Run and Emergency Stop and RESET.
DISPLAY	The DISPLAY Menu provides access to all measurement data, Manual Step functions, the current step in the analysis with elapsed time, the sensor's signal Trend Graph and the Data logger.
PROGRAM	The PROGRAM Menu provides access to the Analysis Cycle, the Extra Cycle, the Calibration Menu and the Setting Menu.
SERVICE	The SERVICE Menu provides access to the analysis parameters, the time, the hour, the blank value, to configure the 4-20 mA output, Alarm Relays, Digital Input and LED MAX and the Blank and Factor values.
? HELP	The HELP Menu includes: Analyzer Installation, Start Up, Start/Stop Commands, Calibration, Program/Modify Cycle, Functions, Shut Down, Maintenance and troubleshooting.

8.4 RUN MENU

The RUN Menu provides access to the Start /Stop functions of the analyzer, Start On-Line, Cycles to Run and Emergency Stop.

8.4.1 START ON-LINE?

By pressing this button the analyzer will start a continuous cyclic analysis based on the steps set in the Analysis Cycle of the PROGRAM menu. ONLINE is now displayed on the button. By pressing the button again, the analyzer will finish the cycle in progress and then wait in STAND-BY mode.

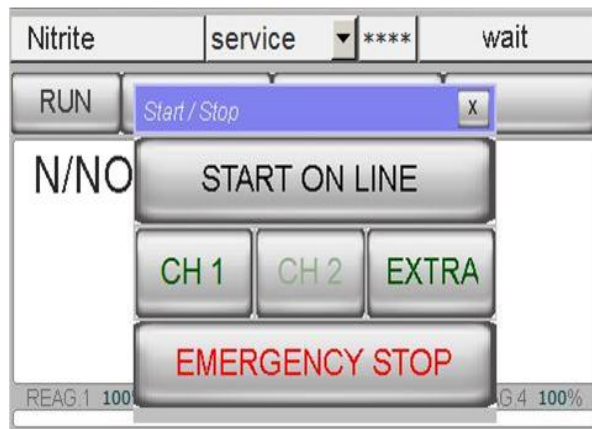

8.4.2 CYCLE Ch1 / CYCLE Ch2 / Cycle Extra

This command starts the analyzer, performing one cycle of analysis on channel 1 or channel 2 or extra auto-function. At the end of the cycle, the analyzer will turn in stand-by conditions waiting for a new user's command.

8.4.3 EMERGENCY STOP

This command will immediately stop the analyzer at the current step of the analysis. The analyzer will go into MANUAL STOP condition. **MANUAL STOP** in red colored letters will appear on the main screen and the FAULT contact will be activated. To restart the analyzer after an emergency stop is necessary to reset the fault. Press RUN then **RESET EM. STOP** yellow colored letters and the analyzer will switch to STAND-BY mode.

8.5 DISPLAY MENU

8.5.1 Display Process Values

The following is a list of the displayed parameters in this menu (read only values)

Sensor: Displays the current measurement of the sensor

Refer: Displays the saved reference value, typically set to 9.00. (first point for the absorbance calculation)

Reading: Displays the saved reading of the sensor that was used for the absorbance calculation. (second point for the absorbance calculation)

Absorb: Displays the last absorbance value calculated.

Blank: Displays the absorbance value of the Blank.

Led: Displays the led voltage supply.

Valid %: Displays the validation value in percent, current reading in calibration solution compared to the calibration value.

Current operation: Displays the current analysis step and time (countdown for the programmed step).

8.5.2 Chart

It displays a graph of the sensor's signal trend during the current analysis cycle, scaled 0-10 arbitrary units, readings higher than 10.00 go off the visible graph. Press CANCEL in the lower left corner of the graph to reset the graph.

8.5.3 Manual Step

This selection provides manual control to each of the programming steps (see list in the section 2.3.1). The operator can choose which single operation to run (select function) and set the time of the operation. This function is protected with the 1st level password and is available only in STAND-BY mode.

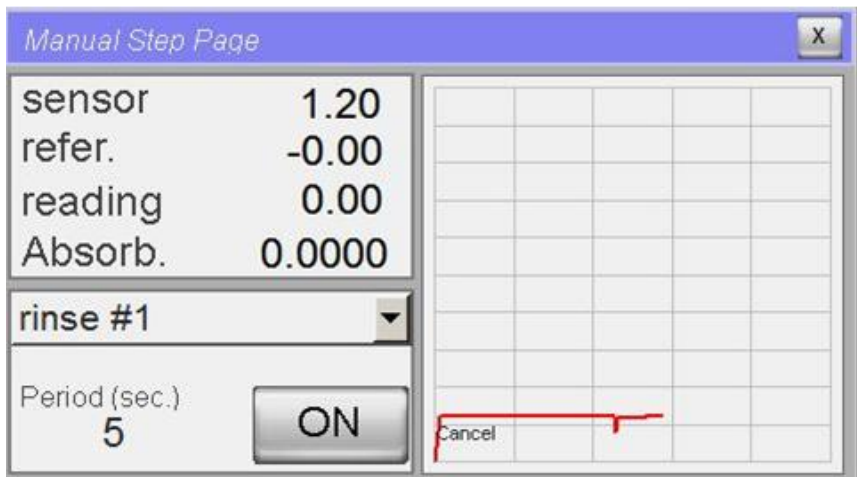
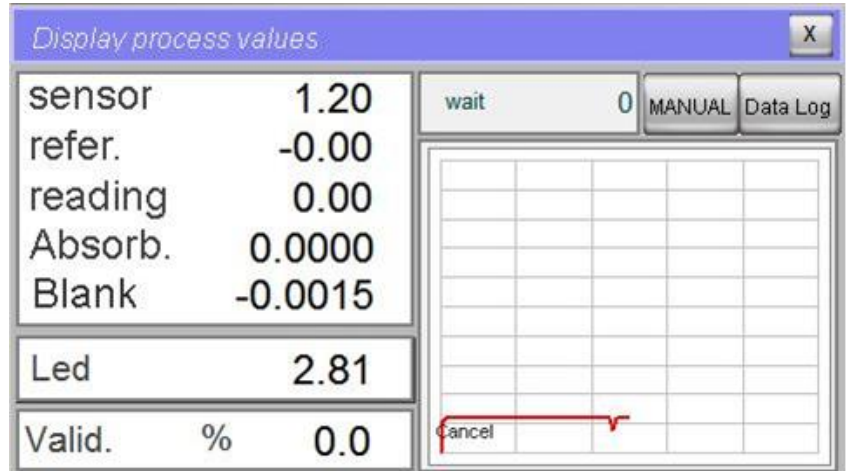

8.6 PROGRAM MENU

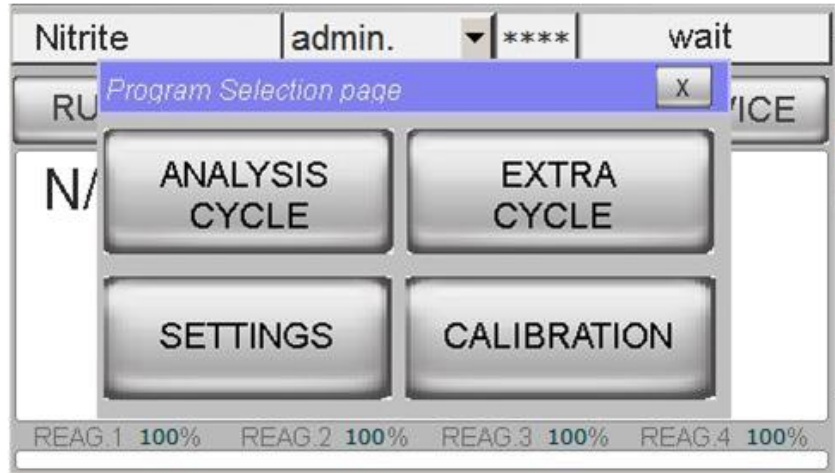

Menu Functions:

Analysis Cycle	Allows the user to program the 30 steps available in the Analysis Cycle. This function is protected with the 2 nd level password.
Extra Cycle	Allows the user to program the 30 steps available in the Extra Cycle. This function is protected with the 2 nd level password.
Settings	Set the ratio of the Analysis Cycles to Extra Cycles, the Alarm Value (low or high), the 4-20 mA Output and to Enable or Disable the Loss of Sample Alarm.
Calibration Menu	Allows the user to perform Blank and Factor Calibrations and to enter the value of the Standard Solution used for calibration. This function is protected with the 1 st level password.

8.6.1 Analysis Cycle

Analysis Cycle displays the numerical step, the time (in seconds) and the function for each of the 30 available steps in the Analysis Program. Touching a function changes it to the next function in the list; all functions are available in this circular list.

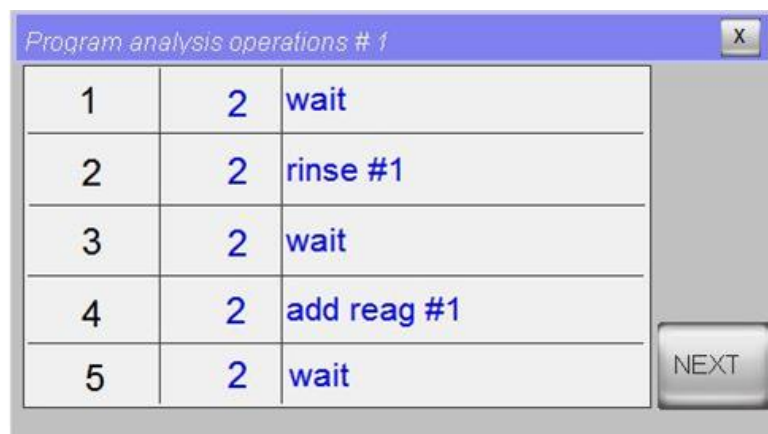

8.6.2 Extra Cycle

Program the 30 available steps with the function and the time in seconds.

Extra cycle operations # 1		
1	2	sample #3
2	2	aux on
3	20	add reag #2
4	4	rinse #1
5	7	wait

NEXT

8.6.3 Settings Menu

Cycles Ratio: Program the ratio of the ANALYSIS CYCLES versus the EXTRA CYCLES (for example ANALYSIS 20 & EXTRA CYCLE 1 means that every 20 ANALYSIS CYCLES the analyzer will perform 1 EXTRA CYCLE.

Result alarm: Program the low / high alarm value. The alarm is expressed in percent of the full scale.

Output signal: Allows the user to enable or disable the 4-20 mA output.

Sample alarm: Allows the user to enable or disable the Loss of Sample Alarm.

CYCLE WAIT Enter the WAIT Time for Step 30 of the ANALYSIS CYCLE

Nitrite admin. ***** wait

Setting page

CYCLES RATIO	date	17:04:2015
Analysis 200	time	09:42
Extra cycles 0	Result alarm 1	80.0 %
Cycle wait 0 sec.	Result alarm 2	80.0 %

OUTPUT SIGNAL ENABLE DATALOG ENABLE

SAMPLE ALARM ENABLE

REAG.1 100% REAG.2 100% REAG.3 100% REAG.4 100%

8.6.2 Calibration Menu

Allows the user to enter the value of the standard used for calibration

Perform manual Blank and Span

Calibration (refer to Section 7)

Displays:

- Calibration Standard Used
- Calibration Factor
- Blank absorbance value
- Calibration Date and Time
- Last Calibration Date and Time and Factor

Calibration

CAL

standard 500.0

factor 0.000

Blank 0.0020 abs

last manual cal. factor 0.000

8.7 SERVICE MENU

This menu is protected with a 2nd level password and contains settings critical to the performance of the analyzer.

These values should only be modified by properly trained personnel.

Service Window #1

Unit: Choose the unit of measurement: ppm or ppb.

Service #1				version 150415		X		
Unit	ppm	Method	N/NO2		Ext. Input		On line	
Sensor av.	200	F. Scale ch1	500		Relay #1		Result Alarm	
Cal. factor min	0.0	F. Scale ch2	0		Relay #2		Result Alarm	
Cal. factor max	0.0	Ref. min	0.00	Bottle ml	1000	Relay #3		Result Alarm
Blank	-0.0005	output	0 %	Cycle sec.	10	Relay #4		Cycle Command

Sensor av.: Set the number of cycles averaged for the sensor reading.

Cal. Factor MIN: Minimum allowable calibration factor.

Cal. Factor MAX: Maximum allowable calibration factor.

Blank: Enter the blank value manually (see section 7.1).

Method: Choose the specific measured parameter (N/NH₃, PO₄, N/NO₂, SiO₂...).

F. Scale1/2: Set the full scale value for the 4-20 mA output (0 to 200.0 ppb = 4-20 mA, above)

Reference Min: This sets the minimum reference value allowable. Values below this value cause a FAULT. This failure is typically caused by a coating on the cell blocking the light transmittance, clean the cell.

Bottle ml: Enter the volume of the reagent(s) bottle(s).

Cycle sec.: Displays the duration of the programmed analysis cycle.

Ext. Input: Allows a selected function to be executed from an external input: extra cycle, on line, print or none.

Relay #1 - #4: Configure the functions of the relays.

- **Cycle Command** (relay activated as programmed in the steps in the PROGRAM menu)
- **Fault Alarm** (relay activated in case of fault alarm)
- **Loss of Sample** (relay activated in case of loss of sample alarm)
- **Result Alarm** (the relay is activated when the result is higher or lower than the

programmed value, Hi/Low Alarm, refer to 8.6.3 Settings menu ☐ Result Alarm)

- **Latch / Unlatch** (Activate a programmed relay with toggle switch.)

Service Window #2

Dual Stream: Yes/No.

Cal. factor: allows the user to enter a Calibration Factor manually into the analyzer (see section 7.2).

Language: Choose Language

Backlight delay min. Set the Time in minutes for backlit display.

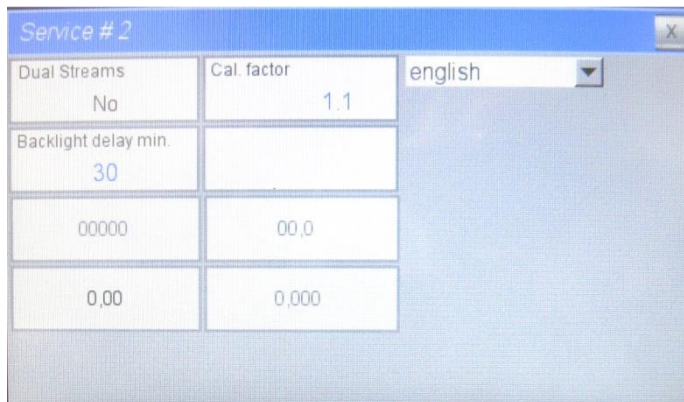

The screenshot shows a window titled "Service # 2" with a close button in the top right corner. It contains a table of settings and a language dropdown menu.

Dual Streams	Cal. factor	english
No	1.1	
Backlight delay min.		
30		
00000	00,0	
0,00	0,000	

8.7.1 Method of Operation

The CA6 analyzer measures the LED intensity to attain the Reference and Sensor values. The absorbance value is calculated by comparing the Sensor value (Reading) and the Reference value.

As the Colorimetric cell becomes fouled, the LED supply voltage yields a lower and lower Reference value. When the Reference value drops to the Minimum Reference value a Fault Alarm is initiated but the analyzer continues to make measurements. When the reference value falls 25% below the Minimum Reference value that is set in the service screen, the Analyzer goes into a Failure Alarm and stops working.

Clean the Colorimetric cell. Press RUN and START ON-LINE to restart the analyzer.

9.0 MAINTENANCE

Basic maintenance on the CA-6 Analyzer requires refilling or replacing reagent containers and cleaning the colorimetric cell on a regular basis.

In addition we advise that you perform an overall visual check of the wetted parts for any leakage. If any leaks are detected, take immediate corrective action. Cleaning of the analyzer cabinet is best performed using a soft, non-aggressive cleaner.

The use of a logbook for registering reagent refilling, corrective measures and performed scheduled maintenance is strongly recommended.

Switch off the power to the analyzer prior to the performance of the basic maintenance work, the CA6 Analyzer cannot be operational during maintenance. Prior to any maintenance work, take into consideration all necessary precautions regarding personal safety (protective clothing, safety glasses etc.).

Always label and rinse all connected tubing with water prior to removal.

Caution



CA-6 Analyzer is based on colorimetric analysis methods, using chemical solutions. Make sure proper safety precautions are taken (e.g. using safety gloves and glasses) when handling chemical solutions.

List of maintenance operations:

9.0.1 Visual check

Visually check the following items whenever possible:

- Liquid leakage
- Cell sample level (during cycle)
- Glass cell cleanliness and condition
- % Reagent levels

9.0.2 Monthly

Visual Check (as above)

Replace Pinch Valve tubing

Clean the Colorimetric Cell

Replace Reagent(s) and reset reagent counters

Verify Micro Peristaltic pumps are primed and pumping

Run Calibrations:

- Blank with DI water,
- Slope with calibration solution

9.0.3 Every 4-6 months (depending on applications)

Replace Peristaltic Pump tubing

Manually clean 3 Way Valve(s), with a syringe

Clean Loop Valve (option) with a syringe

Replace Colorimetric Cell o-ring

Hydraulics tubing replacement

Replace Internal Seal of the mixing pump

Clean / Replace Fittings

9.0.4 Annual

Analyzer general inspection (for qualified personnel only)

9.1 Sample Pump tubing replacement

The peristaltic pump head is located in the Liquids section. Before replacing any tubing, carefully read the Hazards and Dangers list in Section 1 and Health and Safety data sheets for the reagents. Always wear protective clothing, gloves and eye protection. Use extreme care during tubing replacement to avoid spills. See MasterFlex video at <http://www.youtube.com/watch?v=zC1INbSnf8o> .

Proceed as follows:

- Stop the analyzer and switch OFF the power.
- Using the key, open the liquids enclosure.
- Unscrew the four screws that hold the pump head in place.
- Disconnect the pump tubing from its inlet and outlet fittings, use caution to avoid liquid spills.
- Slide the pump head to the left and remove the pump head.
- Separate the two halves. Use care with the rotor and remove the used tubing.
- Place the half containing the rotor with the rollers in the 2, 6 and 10 o' clock positions. Place tubing in the outer groove and against the two rollers as shown. Keep your thumb on the tubing to hold it in place and insert the tubing key on the back of the rotor shaft and push in as far as

possible. Tubing is now positioned in the pump head body. With the key firmly pressed against the rotor, push down while turning counter clockwise until tubing is seated around the rotor.

- The tubing is now in place. Remove key and position other pump half into the rotor shaft and snap shaft. Be careful not to pinch the tubing between the pump halves.
- Verify the pump turns correctly using the key.
- Slide the pump head onto the mounting screws moving the roller block with the key or with a screwdriver until the shaft aligns with the motor drive.
- Secure the pump head with the four screws, hand tighten until it is firmly mounted.
- Restart the analyzer.

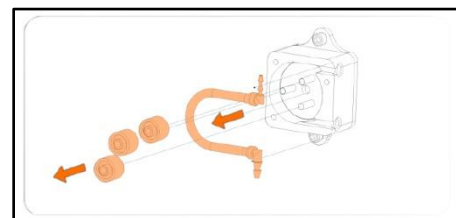
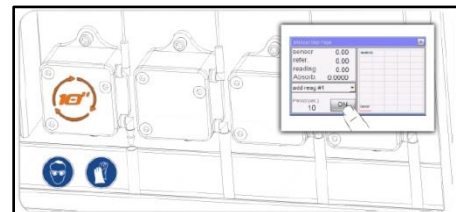

Figure 9-1: Pump tubing replacement details

9.2 Micro Peristaltic Tubing Replacement

The Miniature Pump model peristaltic pumps are located in the liquid enclosure. Before proceeding to replace the tubing, it is recommended to wear adequate clothes, gloves and eyes protection and take extreme care with reagent spills during tubing replacement. (Read reagents' MSDS).

1. Stop the analyzer in stand-by. Open the liquids enclosure and disconnect the reagent's inlet line from its container taking caution to prevent liquid spills.
2. Using Manual mode activate the peristaltic pump for 10 seconds, the pump will suck air and the internal tubing will be empty of liquid.
3. Disconnect the outlet tubing taking caution to prevent liquid spills.
4. Unscrew the 3 TSPEI M3x8 screws using an Allen Key.
5. Remove the Plexiglas pump cover.
6. Remove the 3 black rollers and the used tubing.
7. Disconnect the inlet and outlet fittings from the pump tubing.
8. Insert the inlet and outlet fittings in the new tubing.



9. Position the tubing and fittings deep into the pump head body.
10. Using Manual Mode, activate the peristaltic pump for 1 second and insert one roller at a time in the free position (where the roller is not in contact with the tubing). Repeat for the 3 rollers.
11. Replace the Plexiglas pump cover. Attach the cover with the 3 screws TSPEI M3x8 using an Allen Key.
12. Using Manual mode activate the peristaltic pump for 180 seconds (3 minutes) to settle the tubing into position.
13. Reconnect the outlet tubing to the peristaltic pump fitting.
14. Reconnect the reagent intake tubing to the peristaltic pump fitting.
15. Using Manual mode activate the peristaltic pump for 45 seconds to prime the pump.
16. Repeat the above steps for each additional pump for which it is necessary.

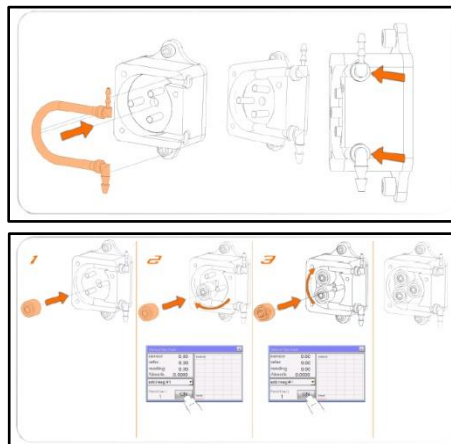

Maintenance frequency for tubing replacement is 70 working hours. To calculate the maintenance frequency for a pump, simply determine the number of analysis cycles per day and the reagent's dose time for each analysis cycle.

Example: 4 analysis cycles per hour (i.e. 96 analysis cycles per day), Dose time 15 seconds for each analysis cycle. Working hours per day = $(96 \text{ cycles/day})(15 \text{ sec}) / 3600 \text{ sec/hour} = 0.4 \text{ hours / day}$

Maintenance frequency = $70 \text{ hours} / 0.4 \text{ hours / day} = 175 \text{ days}$

9.3 Cleaning the Colorimetric Cell

To determine whether the test cell needs cleaning, perform a check of the sensor voltage when DI water is present in the cell

If the sensor value is below 8, perform a manual clean of the test cell prior to changing the LED voltage.

To clean the cell, disconnect all tubes connected to the cell, then rotate it as appropriate to ensure any entry/exit points from the cell can pass through the block without force being applied. Then remove it from the block.

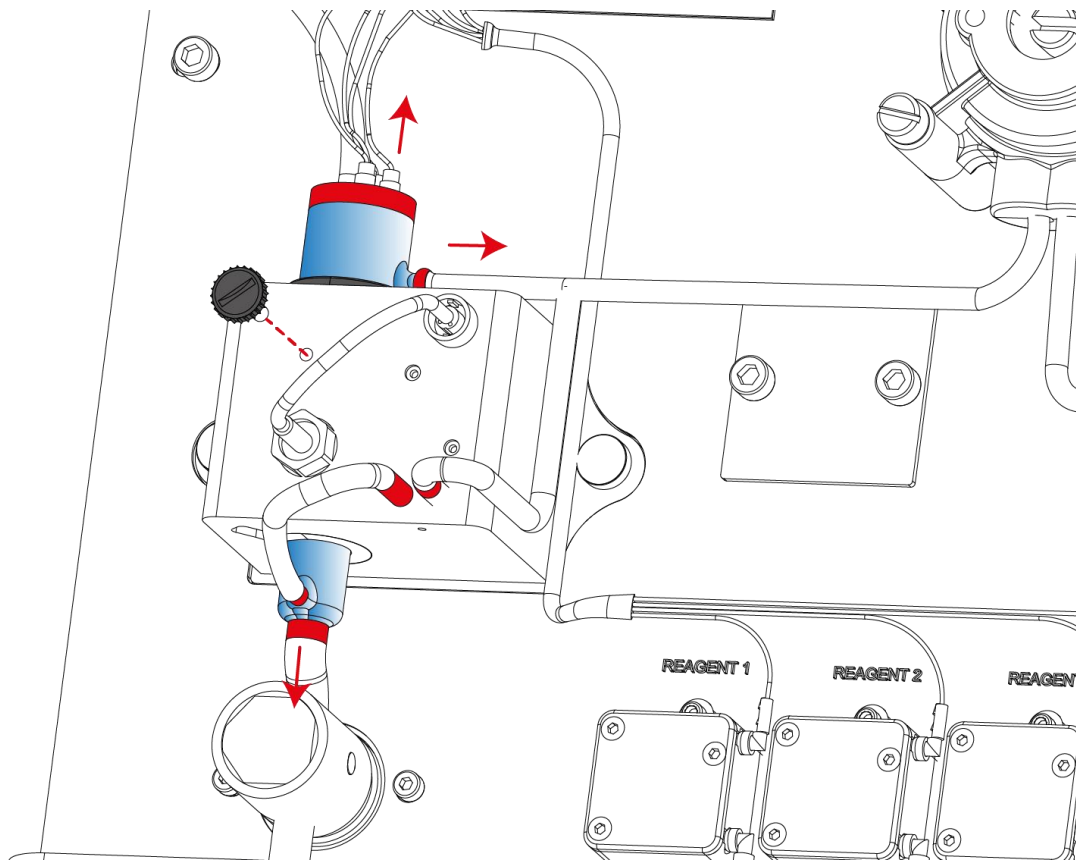

If the smaller path length cell (16mm) is being used, a collar will be present which holds the cell in the correct position in the block.

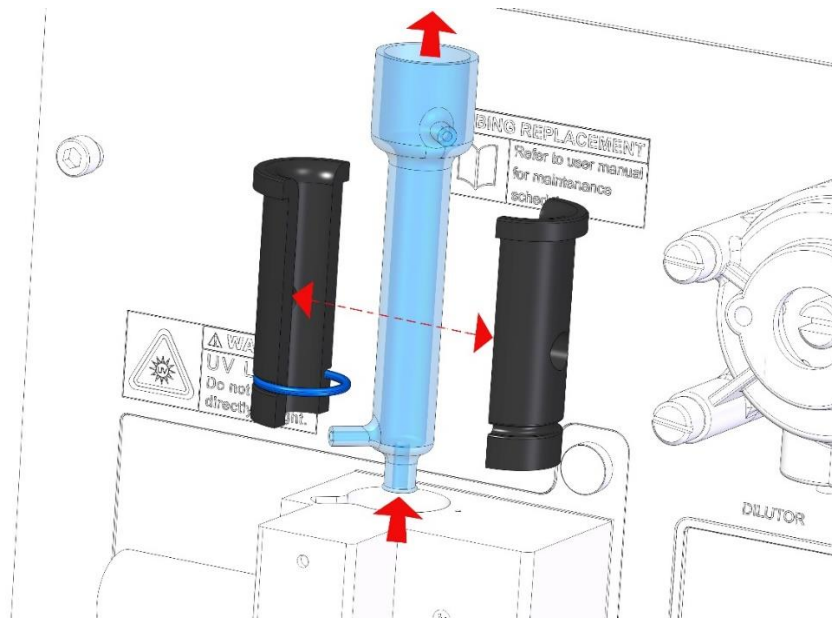

On removal, clean the cell with a small soft brush, deionized water and in the case of severe staining, some dilute acid.

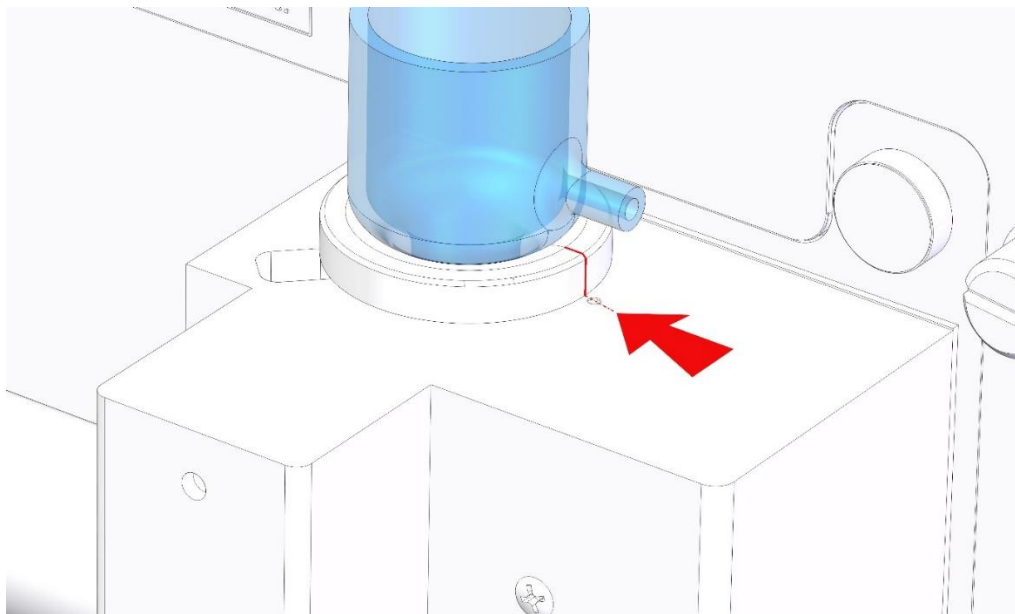

9.4 Spare Parts and Accessories

Contact ECDA factory or your local Rep for Part numbers of accessories and spare parts.

10.0 ANALYZER START UP AND SHUT DOWN

FIRST START-UP PROCEDURE

Refer to Section 6.0 for an in depth procedure.

Open the liquids compartment (the bottom compartment)

Remove the plastic block in the pinch valve (see label)

Install the fast loop reservoir close to the right part of the analyzer and connect the cable of the level switch (fast loop reservoir is an option for online applications)

Connect the drain of the fast loop reservoir with 12 mm tubing

Connect the sample feed to the fitting on the bottom part of the fast loop reservoir

Connect the Norprene tubing from the three way valve, sample port #2 to the fitting on top of the fast loop reservoir.

Prepare reagents and fill the containers delivered with the analyzer

Put the reagent's containers in the dedicated bottle rack of the bench support (optional)

Switch on the analyzer (switch is located on the top compartment)

****Please make sure that the Sleeve Apparatus is positioned correctly. Align the white dots on the sleeve and the heater block. This will ensure that the light is passing through the glass cell. ****

SHUT DOWN PROCEDURE

If the CA-6 Analyzer will be out of service for a period of two weeks or greater, proceed as follows:

1. Empty all reagent containers.
2. Rinse and refill all reagent containers with distilled water.
3. Prime all of the pumps with DI water. (login with 1st level password, press DISPLAY, MANUAL STEP, ADD REAG 1,2,3,4 for 40 seconds each)
4. Disconnect the sample feed line and fill the fast-loop reservoir (if present) with distilled water.
5. With the sample inlet tubing attached to a container of distilled water, run the analyzer for at least 2 cycles.
6. Empty the water from all lines.
7. Put the analyzer in stand-by condition.
8. Turn OFF the power to the analyzer and disconnect the plug from the wall socket.

11.0 DIMENSIONAL DRAWING

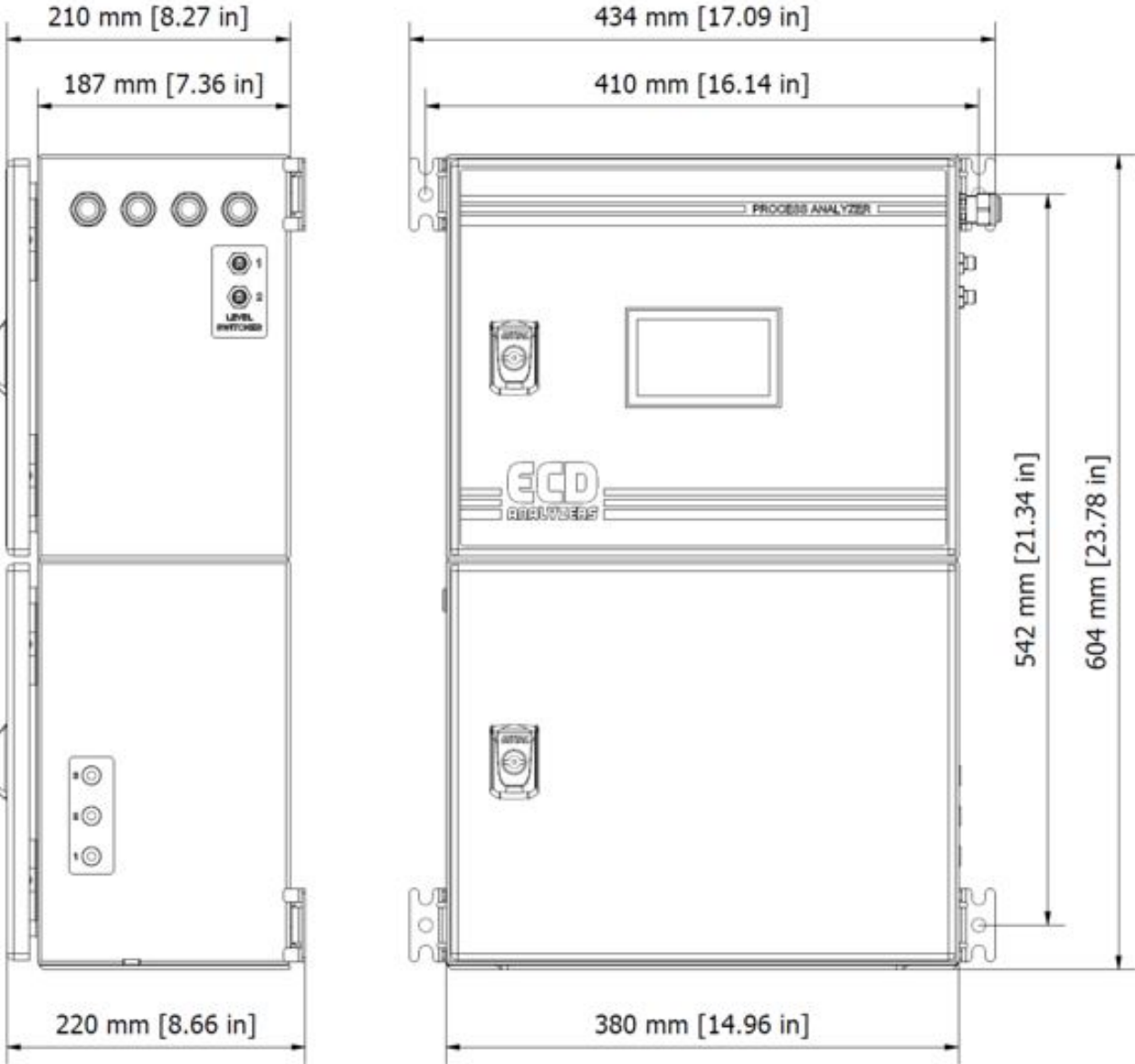



•1500 N Kellogg Dr • Anaheim, CA 92807 • +1-714-695-0051 • FAX +1-714-695-0057
•ECDAnalyzers.com