

USER MANUAL



UV6 COLOR MONITOR



Electrical equipment marked with this symbol can not be disposed of through home or public waste disposal systems after 12 August 2005. In accordance with local and national European regulations (EU Directive 2002/96 / EC), users must return the equipment which is unsuccessful or can no longer be used to the manufacturer, which have to provide free of charge disposal.

Note: To return devices at the end of their useful life, accessories supplied by the manufacturer and all auxiliary items for recycling, contact the manufacturer or the vendor of the device to arrange proper disposal.

INDEX

Section 1 - SAFETY INFORMATIONS	
1.1 Warnings and safety information	5
Section 2 GENERAL INFORMATION	
2.1 Technical Specifications	6
2.2 Method description	7
2.3 Applications	7
Section 3 - INSTALLATION	
3.1 Opening the package	8
3.2 Example of sample suction installation	10
3.3 Installation example for Pressurized Piping	11
3.4 Mounting the instrument	12
3.5 Wall Mount Dimensions	13
3.6 Power supply connection	14
3.7 Signal Connection to the Data Acquisition System	15
3.8 Connecting Sample Level Sensors	17
3.9 Connecting to an RS485 serial data line	18
3.10 Modbus serial protocol	19
3.11 Sample / Dilution Port Connection / Standard Solutions	20
3.12 Reading cell waste connection	21
3.13 Reading cell - Vent connection	22
3.14 Cleaning reagent connection	23
3.15 Cleaning reagent consumption	23
3.16 Kit start up material list	23
Section 4 - START UP OF THE INSTRUMENT	
4.1 Power on	24
4.2 Knowledge of the standard components	26
4.3 Optional components	27
4.4 Take knowledge of the component function	28
4.5 Manual activation of functions	29
4.6 Single cycle, Online cycles and Extra cycle	30
4.7 Starting a single cycle	31
4.8 Starting an Extra cycle	31
4.9 Starting Online Operation	31
4.10 Example of measurement and extra cycle	32
4.11 Emergency stop	35
4.12 Loss of sample	35
4.13 Logic operation and display page.....	36
Section 5 - SETTINGS	
5.1 Settings page.....	38
5.2 Service page.....	40
5.3 Relays.....	42

Section 6 - ANALYSIS CYCLE AND CALIBRATION

6.1 About the method.....43

6.2 Absorbance calibration.....43

6.3 Process value correlation.....45

Section 7 - DATA STORAGE

7.1 Datalogger page46

7.2 Saving data on USB memory46

Section 8 - MAINTENANCE

8.1 Maintenance operations.....47

8.2 Dismounting the measure cell.....48

8.3 Reagent pump maintenance.....51

8.4 Alarms and troubleshooting.....54

8.5 Electronics check.....58

1 - SAFETY INFORMATION

Before installing and operating the analyzer, read this manual thoroughly. Please pay particular attention to all the labels applied to the analyzer and to all the hazard information indicators in this manual.



This symbol indicates that you must refer to this manual for proper use of the equipment. Only qualified operators, properly trained on the use and maintenance of the analyzer can carry out service activities on the equipment.



This symbol indicates the existence of a risk of electric shock and/or electrocution. Only operators qualified for these activities can perform maintenance and control operations on the equipment bearing this label, always after unplugging it.

Parts involved:
- input terminal block in the upper box
- xenon lamp and its power wires in the lower liquid section



This symbol indicates the possible presence of UV radiation during certain phases of operation. The xenon lamp must not be removed from its housing while the device is operated.



This symbol indicates the risk of burns and physical damage caused by the presence of hazardous chemical compounds. Only operators qualified for these activities can handle and perform service operations that may involve the risk of contact with such compounds. Before carrying out any type of service activities on the analyzer, please read the safety data sheets of the different chemicals used and take all precautions specified therein.

Parts involved:
- cleaning reagent bottle
- cleaning reagent suction pump and the pipes connected to it

The manufacturer shall not be held responsible under any circumstances for improper use of the equipment.

The head of department and the machine operator must comply with the following rules and with the provisions of current legislation on the safety and health of workers.

The use, maintenance, and repair of the analyzer are permitted only to persons authorised for such operations. These operators must be physically and mentally capable to perform such activities, which can not be performed under the influence of alcohol and drugs.

When the analyzer is not being used it must be protected from voluntary or involuntary activation, after disconnecting the power supply.

Failure to follow the instructions given and/or failure to pay attention to the hazard indicators may cause serious risks of physical damage to operators and breaks or malfunctioning of the analyzer.

All the components of the analyzer are placed within a panel closed by a door with a special key, supplied only to maintenance operators.

The analyzer must, then, be used under operating conditions with both lower and upper doors closed.

2 - GENERAL INFORMATION

2.1 Technical specification

Measuring principle	The xenon lamp produces a UV light radiation that pass through the sample water in a quartz measuring cell. Measurement of water color by absorbance at 350nm expressed in Hazen scale or Platinum-Cobalt scale.
Measured variables	UV Color (Hazen scale or Platinum-Cobalt scale)
Measuring range	0 to 500 Pt-Co units (0 to 500 Hazen units) All derivated higher range using internal dilution (up to 40 times dilution).
Analysis frequency	Programmable by the user
Reproducibility:	±2 % of reading for low values < 10% f.s.
Accuracy:	±5 % of reading or ± 1 Pt / Co (whichever is the greater)
Power supply	110-230 VAC , 50/60 Hz , 80VA - optional 24 VDC
Working conditions	Operating Temperature: 41 - 113 °F (5 - 45 °C) Humidity: 10 to 90% non-condensing (indoor use, outdoor installation only possible with protective cabinet or shelter not included)
Cabinet	Cold-rolled steel painted with epoxy powder
Protection grade	IP54
Mounting	Wall mount (standard), bench top support or panel mount (options).
Dimensions (H x W x D)	23.6 x 15.0 x 8.2 in / 606 x 380 x 209 mm
Weight	Approx. 44 lbs (20 Kg)
Output signals	N. 2 analog output 4-20mA , serial com. Modbus RTU RS485
Alarms	4 SPDT programmable potential free relays, N.O. or N.C.
Datalogger	Integrated with USB download (saved as .csv)
Automatic functions	Calibration, cleaning, dilution
N° of streams	1, 2 with integrated switching valve
Sample	Pressure-free from overflow vessel Temperature: 41 - 122 °F (5 to 50 °C) Flow Rate: 80 to 500 mL/min Connection: 6 mm (¼-in.)
Drain	Pressure-free, atmospheric drain Connection: 12 mm (½-in.)
Maintenance frequency	Cleaning pump tubing every 70 h (8-12 months) Depending on configuration: Sample pump tubing and valves tubing replacement every 4 months

2.2 Method description

The xenon lamp produces a UV light radiation that pass through the sample water in a quartz measuring cell. Measurement of water color by absorbance at 350nm expressed in Hazen scale or Platinum-Cobalt scale.

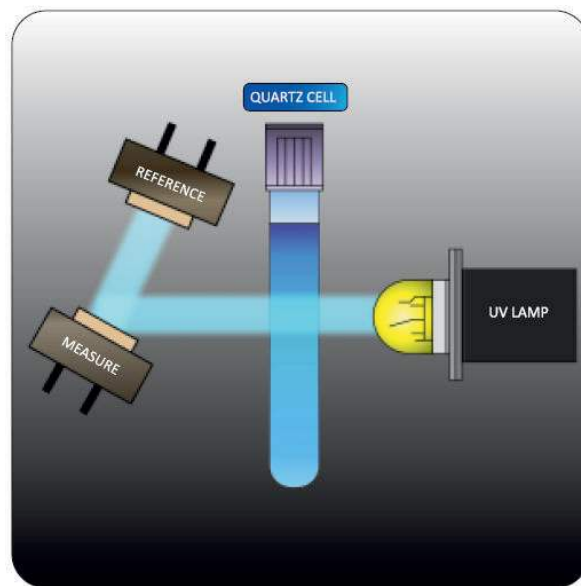

2.3 Applications fields

Municipal waste water
Industrial waste water
Rivers and surface water
Drinking water
Monitoring process liquids
Measurement of water quality for distribution or discharge

3 - INSTALLATION

3.1 Opening the package



Caution:
 please take all the precautions required for handling and lifting the box containing the analyzer.
 The instrument weight is approx. 44 lbs (20 Kg)

For safety reasons, when removing the packaging of the equipment, please check for any visible defects and, if necessary, inform the supplier.



Parts inside the package apart from the user manual		
A	UV6 Color Analyzer	UV6-Color-X-X
B	Fast loop reservoir with level switch for sample	A46ERLS000
C	Start-up kit	A46KIT0050
D	Bottle (empty) for cleaning solution	A46H2SO4B1

These are the codes to identify the different configuration analysers

UV6-Color - X - X

Single stream analyzer, no dilution no autocalibration	0
Two valves analyzer (dual stream or single stream and autocalibration or single stream and dilution)	2
Three valves (dual stream and autocalibration, dual stream and dilution or diluted single stream with autocal)	3

22 mm cell analyzer	UL
12 mm cell analyzer	L

An optional component may be present, although not visible when opening the package because it is mounted inside the analyzer.

Dilution option (mounted inside the analyzer's case)	A46CLDM00
--	-----------

Optional accessories		
for Dual Stream option	Fast loop reservoir with level switch for the second sample	A46ERLS000
for Dilution option	Fast loop reservoir with level switch for the dilution water	A46DWLS000
for Autocal option	Bottle for standard solution	A46COLB1

3.2 Example of sample suction installation

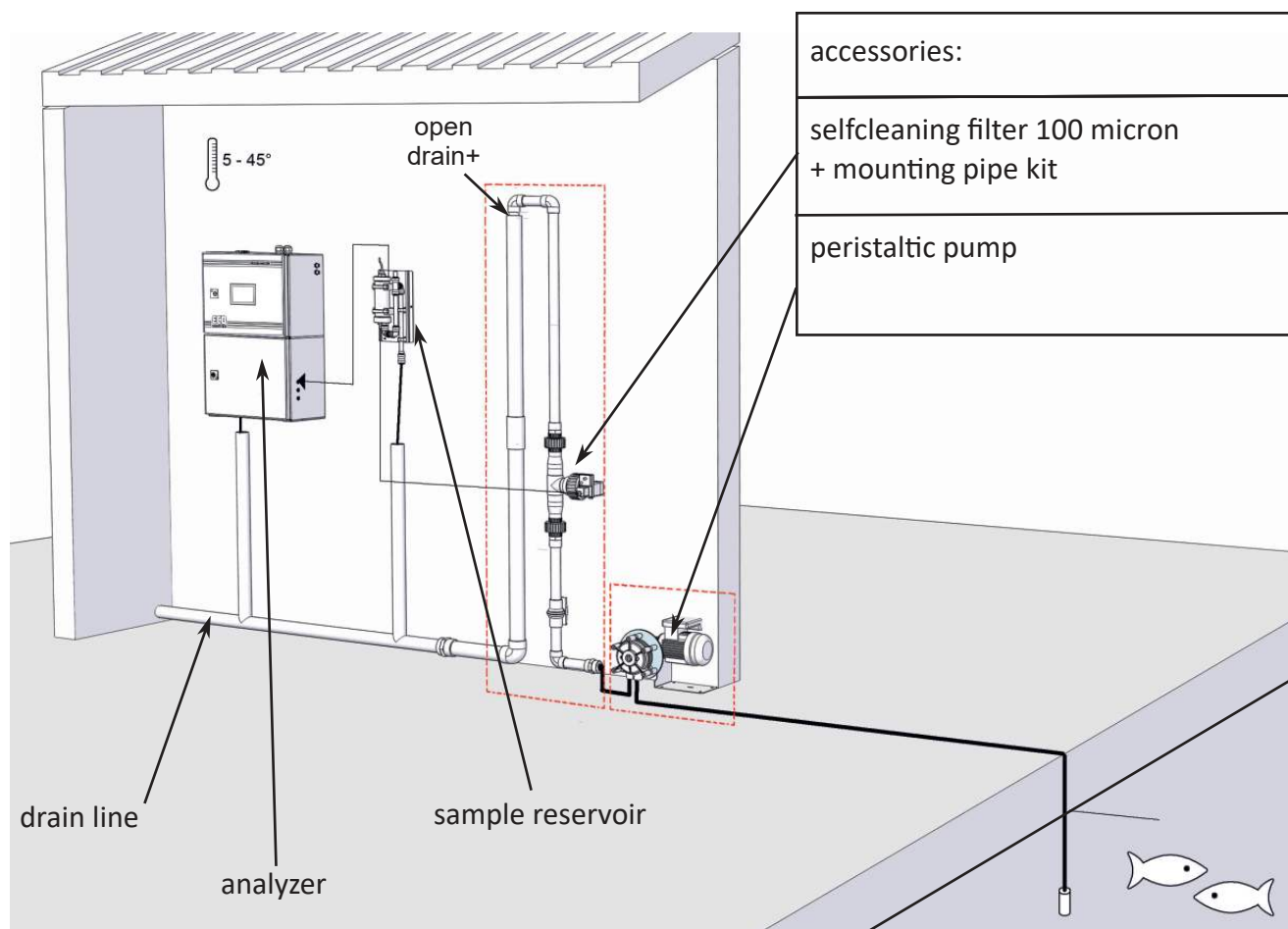

In the example, a large sample quantity is sucked by a peristaltic pump from an underlying head and sent to a self-cleaning filter.

A lower sample flow (filtered at 100 microns) comes out of the filter and recirculates inside the tank before being drained. The unfiltered sample portion is drained and transferred to the upper head of the filter to create the necessary pressure to allow the filtered liquid to spontaneously flow.

From the tank, according to the analysis timing set, the analyzer collects the sample to perform the analysis. If the filtered sample level in the cylinder is not reached, the level contact in the lowered position does not allow the calculation of the result and prevents the next cycle from restarting until the level returns to normal.

The sampling peristaltic pump can run continuously or only for a period of time before the analysis, driven in this case by the analyzer itself (control panel operated by the installer) through one of its potential free relay contacts.

The suction line from the tank may need heat tracing to prevent occlusion due to negative temperatures.

The installer shall implement a drain line, which, however, shall not create a backpressure to the free drain of the analyzer and recirculation tank.

3.3 Example of sample from pressurized piping

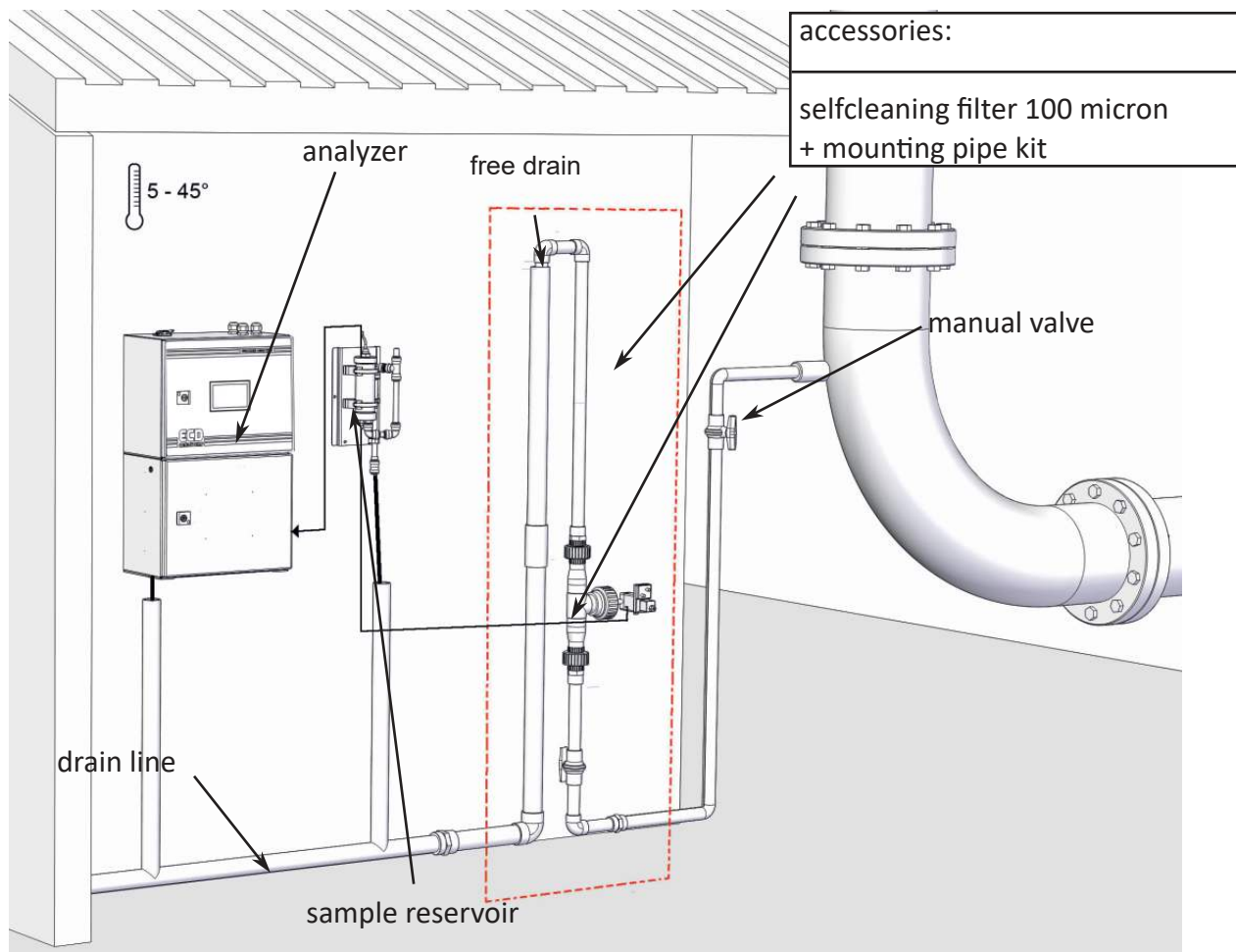

In this example, the sample is taken from a pressurized process pipe and a flow of 500-1000 l/h (adjusted by the sampling valve) crosses the self-cleaning filter to reach the drain line.

The conformation of the pipe where the filter is inserted produces a positive suction head (the drain is in the upper position compared to the height of the filter) which allows the fraction of filtered liquid to escape and reach the recirculation tank.

A filter must be mounted if there are any suspended solids greater than 500 microns.

If the filter is not needed, a sampling needle valve to adjust the maximum flow rate of 500 ml/min must be mounted, from the pipe to directly send liquid to the recirculation reservoir.

Also in this example, the installer shall implement a drain line, which, however, shall not create a backpressure to the free drain of the analyzer and recirculation tank.

3.4 Mounting the instruments

The analyzer and the sampling cylinder must be mounted vertically on a wall or support suitable for their weight and not subject to vibrations. Use suitable screws (not included in the supply) to fasten them only on the side brackets (ear clips) of the instrument and in the holes of the tank metal plate. Mount them so as to get the display at eye height (160 cm / 5 feet).

Since the sampling connections and level contact connectors are on the right side of the analyzer, install sample reservoir and dilution water sampling to the right of the instrument.

Please consider that the surrounding space must allow easy opening of the doors (upper and lower). The sampling reservoir can be mounted below the analyzer also, if necessary.

A minimum distance of 10 cm (4 in) is required between the wall to the right of the instrument and the cylinder.

Instrument configuration	Fast loop reservoir to install
Standard single stream	1 x A46ERLS000
Dual stream	2 x A46ERLS000
Single stream with dilution	1 x A46ERLS000 + 1 x A46DWLS000
Dual stream with dilution	2 x A46ERLS000 + 1 x A46DWLS000

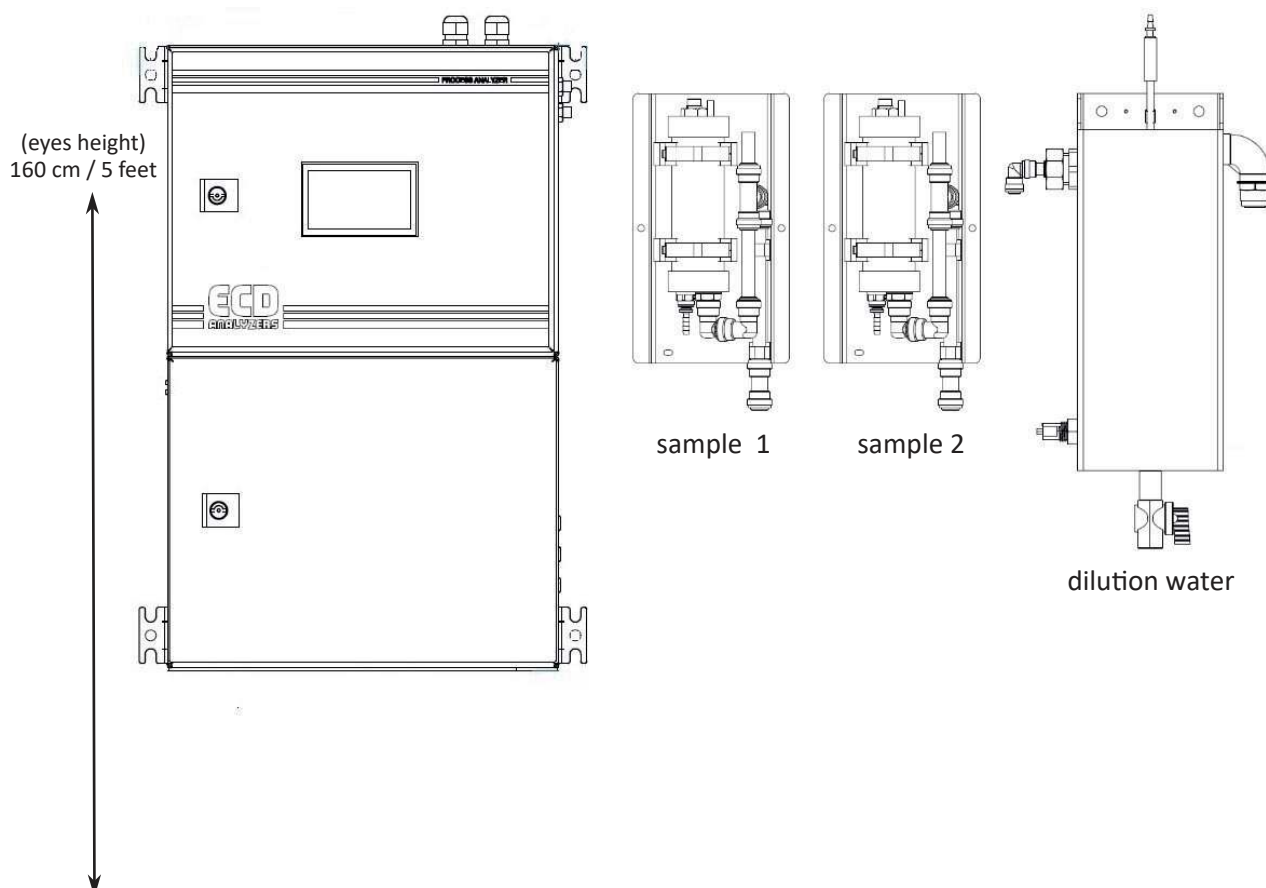

3.5 Wall mounting dimension

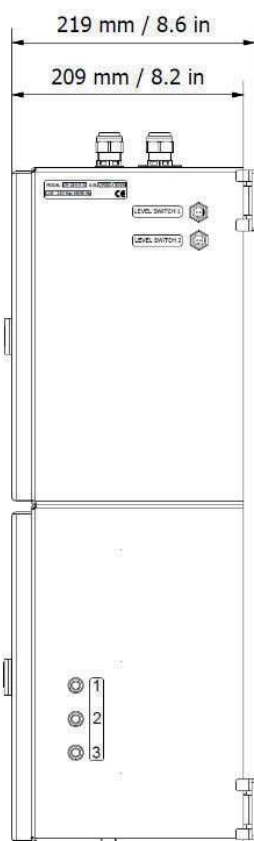

Analyzer UV6 Color

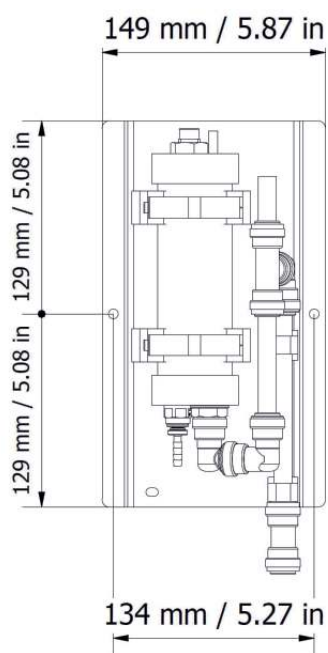
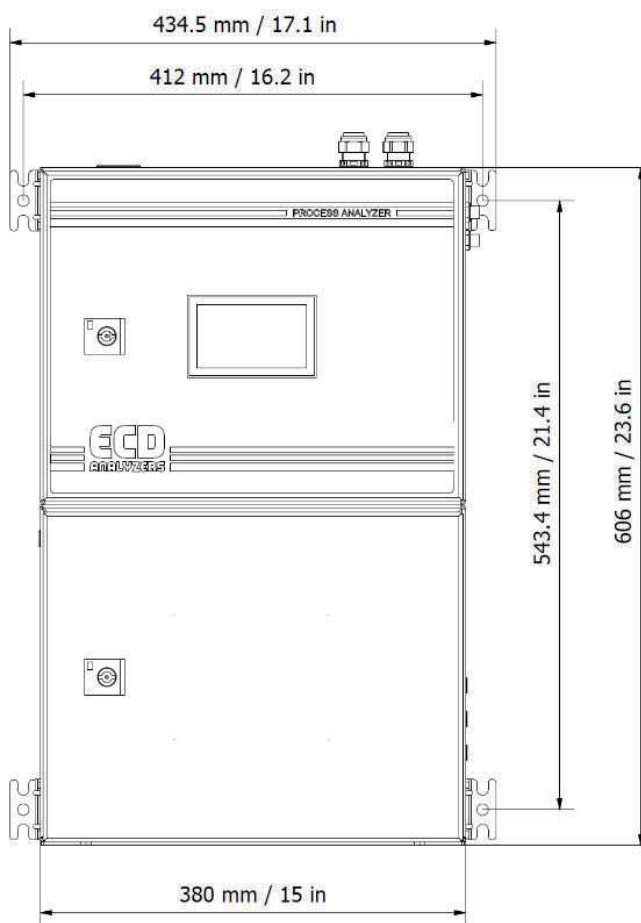

Fast loop reservoir with level switch
p/n A46ERLS000

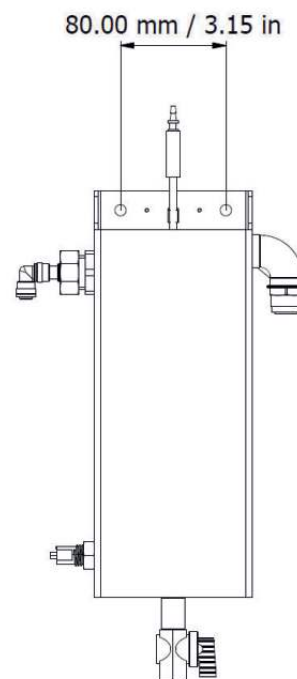

dilution water reservoir
p/n A46DWLS000

3.6 Power supply connection

Europe Plug

The electrical power is supplied by the analyzer's cable with a CEE7/7 SCHUKO Europe plug

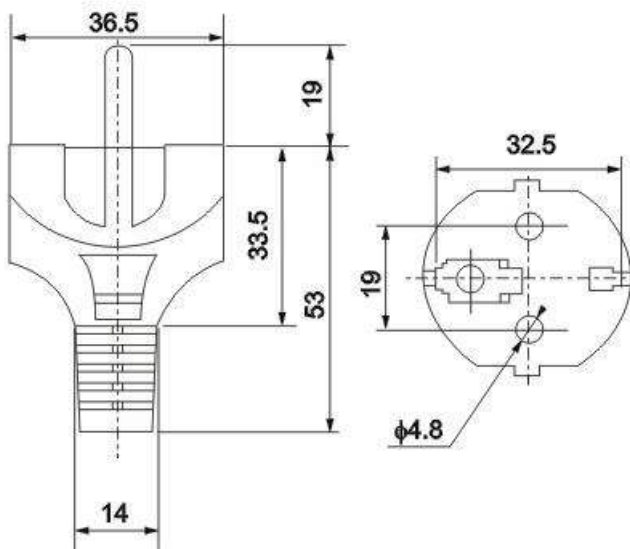

2.5 mt lenght

Color codes

- BROWN Phases
- BLUE Neutral
- GREEN/YELLOW - Protective earth/ground

The analyzer, in accordance with CEI EN 61010-1 standard on electrical safety, has passed the following factory safety tests:

- continuity test
- protective earth test
- insulation resist test
- high voltage test AC
- leakage current test

In addition to the tests carried out by the manufacturer, the installer shall:

- make sure that the power cord was not damaged when the packaging was removed or when the instrument was fixed by the installer;
- check the condition of the earthing conductor of the socket where the power cord will be connected;
- provide adequate protection against overloads and over-voltages in the line where the power cord of the device will be connected;
- check for compliance of the power line with any applicable safety standards.

USA Plug

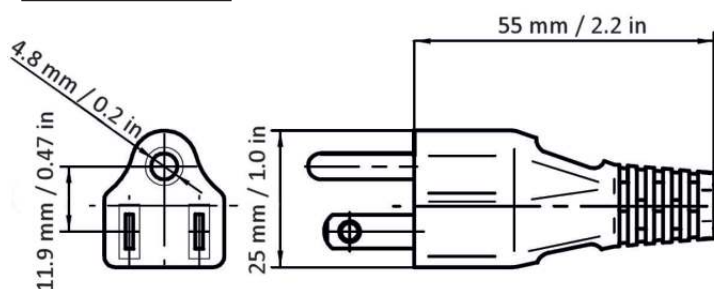

2 mt lenght

Color codes

- BLACK Phases
- WHITE Neutral
- GREEN - Protective earth/ground

3.7 Signal connection to the data acquisition system

To connect the signals and the contacts to the acquisition system, proceed as follows:

- use up to 2 cables with a maximum diameter (insulation included) of 12 mm (0.5 in) ;
- pass the cables into the two free PG13.5 cable glands on the top right side of the instrument;
- a hole with a diameter of 30 mm on the top wall (to the left of the cable glands) can be used as an alternative to the 2 PG13.5 cable glands for a larger size cable gland (not supplied);
- remove the electrical insulator from each wire and place it into the terminal making up the terminal block on the top of the instrument. Use a screwdriver with a 3 mm (1/8 in) cutting width and make sure that the wire is secured inside the terminal;
- make sure that the cable glands are perfectly sealed to prevent dust and moisture infiltration;

Please refer to the connection diagram below

TERMINAL	CONNECTION	NOTE
1 2	- remote input + remote input	connect to a SPDT contact
3 4	- 4-20 mA analogic signal channel 2 + 4-20 mA analogic signal channel 2	max impedance 500 ohm protected by 50mA Fuse
5 6	- 4-20 mA analogic signal channel 1 + 4-20 mA analogic signal channel 1	
7 8 9	COMMON relay 1 and 2 relay 1 relay 2	load max 5 A 250Vac configurable as NC or NO SPDT or powered 24 Vdc (jumpers setting)
10 11	relay 3 relay 4	
12	COMMON relay 3 and 4	

each contact relay can be set following the below table

<p>NORMALLY OPEN</p>	<p>when the relay is OFF the contact opens, while when the relay is ON the contact closes. In the case of loss of power, analyzer OFF, the contact is open .</p>
<p>NORMALLY CLOSED</p>	<p>normally the relay is ON and the contact closes, while when the relay is OFF for alarm condition the contact opens. In the case of loss of power, analyzer OFF, the contact is opened .</p>

To set one of the two conditions (default N.O. usually open) you must access the top by opening the door. Remove the cover protecting electronic parts (L-shaped metal sheet) by unscrewing the 5 plastic screws holding it closed.

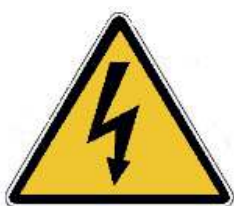

Unplug the power cord before operate !

Each relay can be set independently by placing the jumpers as follow

jumper right = N.O. normally open configuration
jumper left = N.C. normally closed configuration

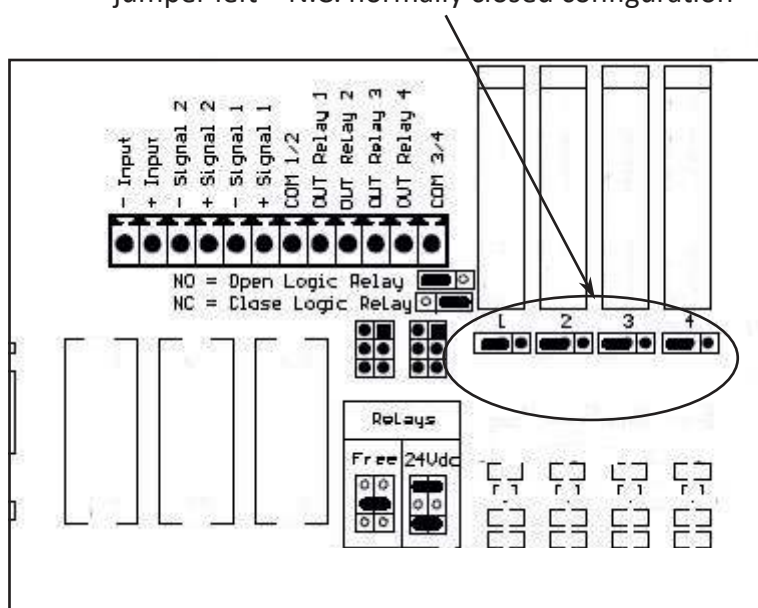

Relays are divided into two groups (1-2 and 3-4) with a shared contact for each group. They can be configured as voltage free (SPDT, free contact, etc.) or powered by 24VDC and protected by a 1 A shared fuse, depending on the position of the jumpers shown below:

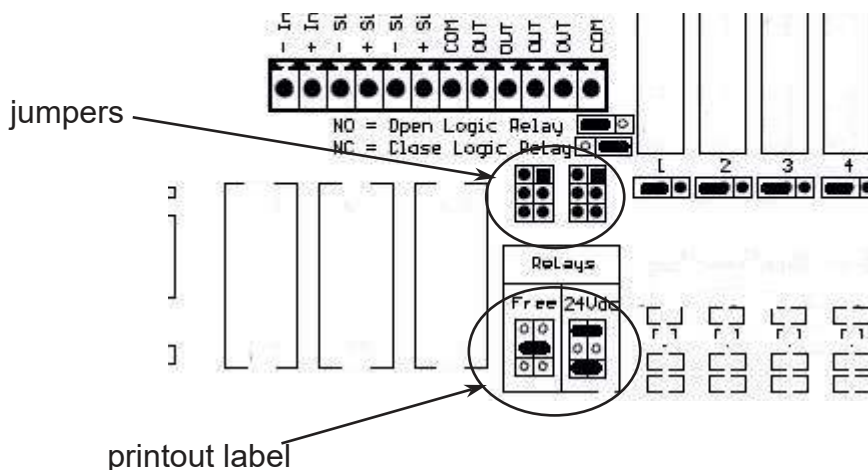

The silk-screen print on the electronic board shows the position of the two jumpers (if the relay contacts are powered by 24 volts) or the single jumper (default condition) if the relay contacts are voltage free.

The setting will work for the two relays of the group, which can not be managed separately.

3.8 Connecting sample level sensor

The sample recirculation tanks with level contact, positioned to the right of the device, have a level contact showing the presence or absence of the sample inside the instrument itself.

The signal reaches the device through the connector-terminated cable to be plugged into its socket placed on the right wall above the analyzer.

There are two labels to identify the correct connection.

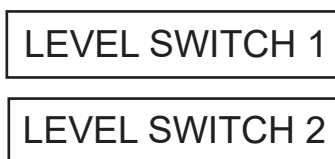

In the single-sample configuration, the level sensor of the single recirculation tank must be connected to the Level Switch 1 socket.

Below the contact logic :

SAMPLE PRESENT	floating element UP	Contact OPEN
SAMPLE NOT PRESENT	floating element DOWN	Contact CLOSED

3.9 Connecting to a RS485 serial data line

The analyzer has a two-wire RS485 serial interface.

There are two screw terminals on the main board, on the top left.

To access them, remove the cover protecting electronic parts (L-shaped metal sheet) by unscrewing the 5 plastic screws holding it closed.

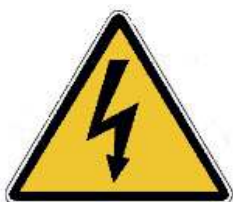

Unplug the power cord before operate !

Connect the wires with an appropriate section to the system network, considering the right polarity:

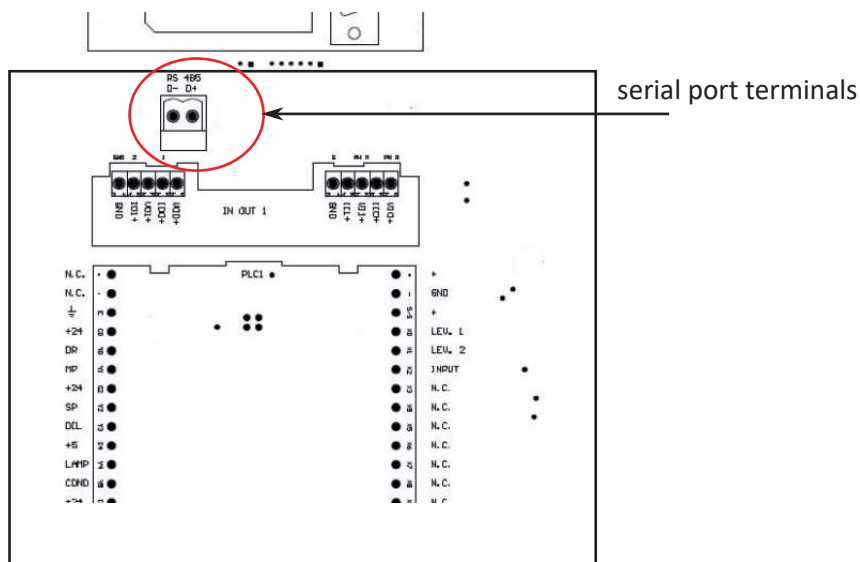

3.10 Modbus serial protocol

The analyzer exchanges information on the serial line via the Modbus RTU protocol in Slave mode.

For the settings and the data exchange table, please follow the steps below.

Baud Rate	9600
Data bits	8
Parity	E
Stop bit	1
Analyzer I.D. (slave , node number) number	the last two digits of the serial (i.e. s/n UV145 = I.D. no. 45)

Address	Format	Alias
900	32-bits float (CD-AB)	result CH1
902	32-bits float (CD-AB)	result CH2
800	bit	“online” condition
801	bit	single cycle running
802	bit	“stopped” condition
803	bit	extra cycle running
806	bit	loss of sample 1
807	bit	loss of sample 2
808	bit	optics alarm
809	bit	callibration alarm

3.11 Sample/Dilution/Standard solution connection

The analyzer takes samples or standard solutions through a peristaltic pump.

The same pump can pick up to 3 different liquids through 3 clamp valves located in the hydraulic power unit.

The possible configurations are shown below:

CONFIGURATION	VALVES	CONNECTIONS
single channel without autocalibration or dilution	0	port 1 : sample
single channel with autocal(zero) or dilution	2	port 1 : sample port 2 : zero water or dilution
single channel with autocal	2	port 1 : sample port 2 : standard solution
dual channel without autocal or dilution	2	port 1: sample 1 port 2: sample 2
dual channel with autocal (zero) or dilution	3	port 1: sample 1 port 2: sample 2 port 3: zero water or dilution
dual channel with autocal	3	port 1: sample 1 port 2: sample 2 port 3: standard solution
single channel with autocal (zero e span) and dilution	3	port 1: sample port 2: dilution port 3: standard solution

For the connection, identify the defined configuration and connect the pipes supplied with the start-up kit (norprene 1/4 OD) to its straight fittings coming out of the 3 inputs on the right side of the hydraulic power unit.

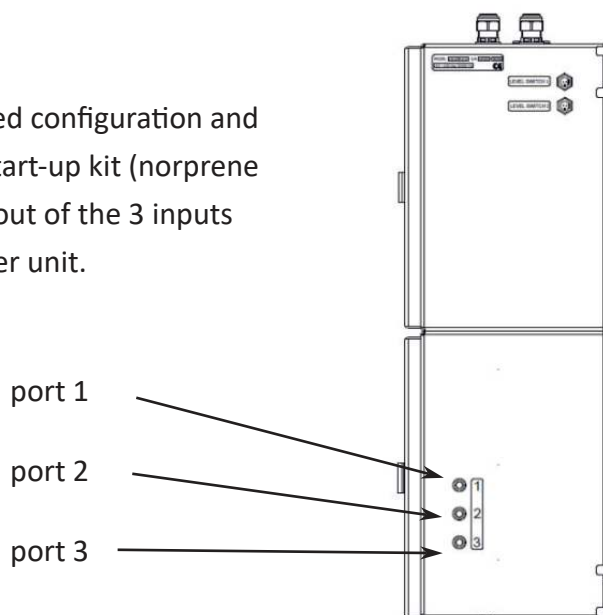

The pump head is designed so as to suck the sample and the calibration liquids contained in the bottles placed at the lower (head) level, and to suck even liquids from bottles placed on the ground.

The tanks can be placed both at the top and bottom of the suction port, while, to ensure dosage precision and prevent any undesired liquid spills onto the hydraulic unit, piping connections to pressure lines must be absolutely avoided if pressure exceeds 0.1 bar (1 meter of water column).

3.12 Reading cell - waste connection

Connection to the drain line is provided by the flexible tube 12 mm OD (0.5 in OD) provided with the start-up kit to be connected to the hose connector located below the analyzer.

Please note that the liquid must be drained by allowing its free fall, therefore any backpressure have to be avoided.

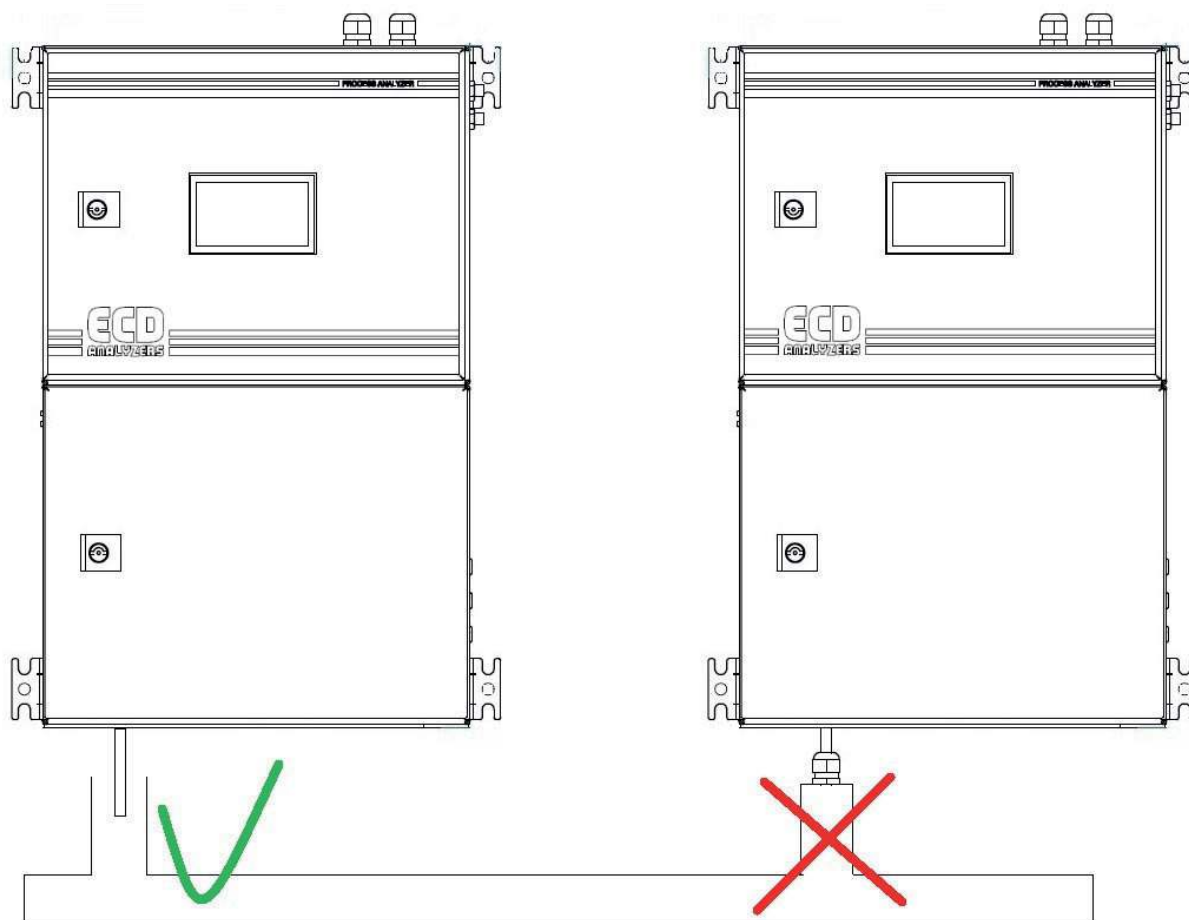

3.13 Reading cell - VENT connection

To ensure the free fall of the liquid contained the reading cell at the end of the analysis or during all rinsing operations, a hose connector is placed on the cell cap and, through a norprene tube 7/16 OD conveys any vapours outside the lower cabinet (left side).

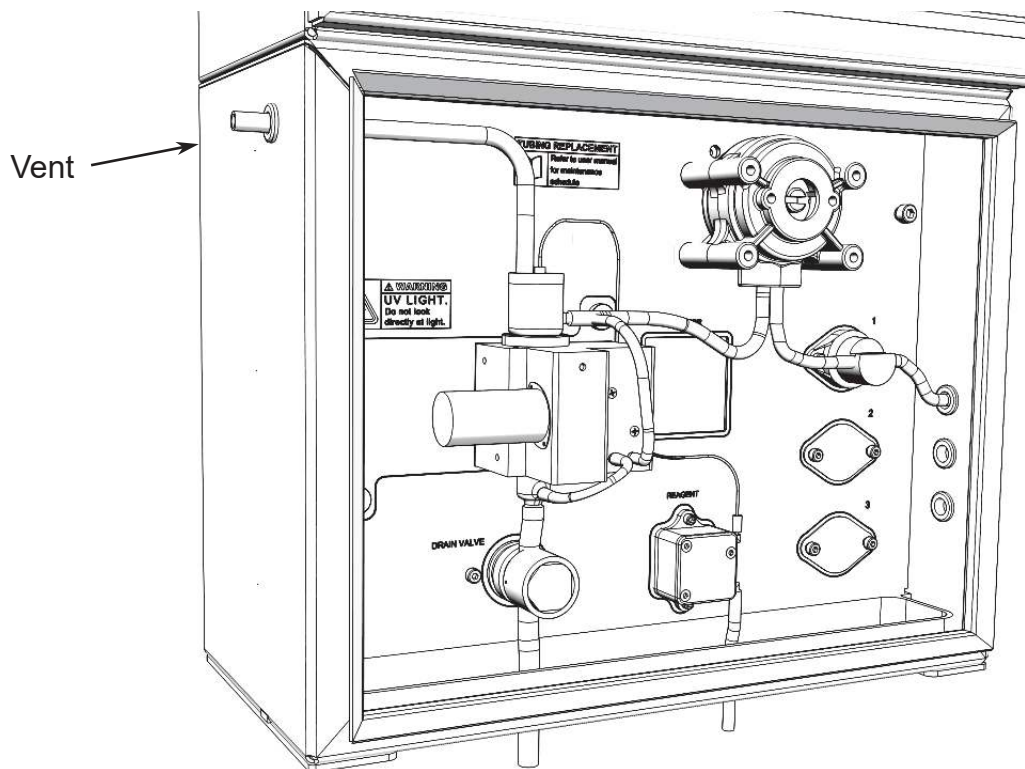

This vent port can may be conveyed out through an extension tubing, preventing corrosion from gas coming from sample or cleaning solution, especially when the analyzer is mounted in a small cabinet

Be aware to avoid counter pression or condensation in the extension tube.

3.14 Cleaning/reagent solution connection

To connect the bottle containing the cleaning solution, use the rigid sampling pipe provided with the start-up kit.

The bottle should be placed below or next to the analyzer at the maximum distance equal to the length of the pipe.

No extension is provided for this pipe, to avoid that the small head of the peristaltic pump is not sufficient to suck the fluid from a too low level.



Please pay close attention when handling the pipe and the cleaning reagent bottle if these have already been filled, at least once, with corrosive liquid. Use protective gloves and goggles to prevent any spilled liquid from coming in contact with the eyes and skin.

3.15 Cleaning/reagent solution consumption

Consumption of the cleaning reagent and its 1 l bottle life depend on the analysis and cleaning frequency, which can be different based on the application and the sample.

In this regard, please consider the two examples below:

Example A : analysis carried out every 5 minute, an EXTRA cycle every 100 cycles

consumption per cleaning (Reagent = 100 sec.) : 5 ml

daily consumption: 15 ml

1 l bottle life : 60 days approximately

Example B : analysis carried out every 10 minutes, an EXTRA cycle every 100 cycles

daily consumption: 7.2 ml

1 l bottle life: 120 days approximately

3.16 Start up kit - material list

These are the material present in the start up kit:

Silicon tubing 2 mt (6.5 ft) for drain connection	n. 1
Norprene tubing size 1/8 OD with 30 cm straw for cleaning/reagent	n. 1
Norprene tubing 1 mt (3.2 ft) size 1/4 OD for port 1 - 2 -3	n. 3
RITTAL key for instrument door	n. 1

4 - START UP OF THE INSTRUMENT

4.1 Power on

After checking for proper power supply, you can turn on the device through the switch located inside the upper compartment.

The analyzer display takes a few seconds to turn on, during which a safety warning screen appears followed by the main screen.

Please note that the device will get back to the configuration set when turned off. If the previous shutdown had been caused by a power loss, and the analyzer was set to ONLINE (continuous consecutive analysis cycles), when restarting the machine, you will get the same configuration with consecutive analysis cycles.

If, on the other hand, the analyzer was set to Stand-by before being turned off, you will get the same configuration when restarting it.

Below is the screen you will see

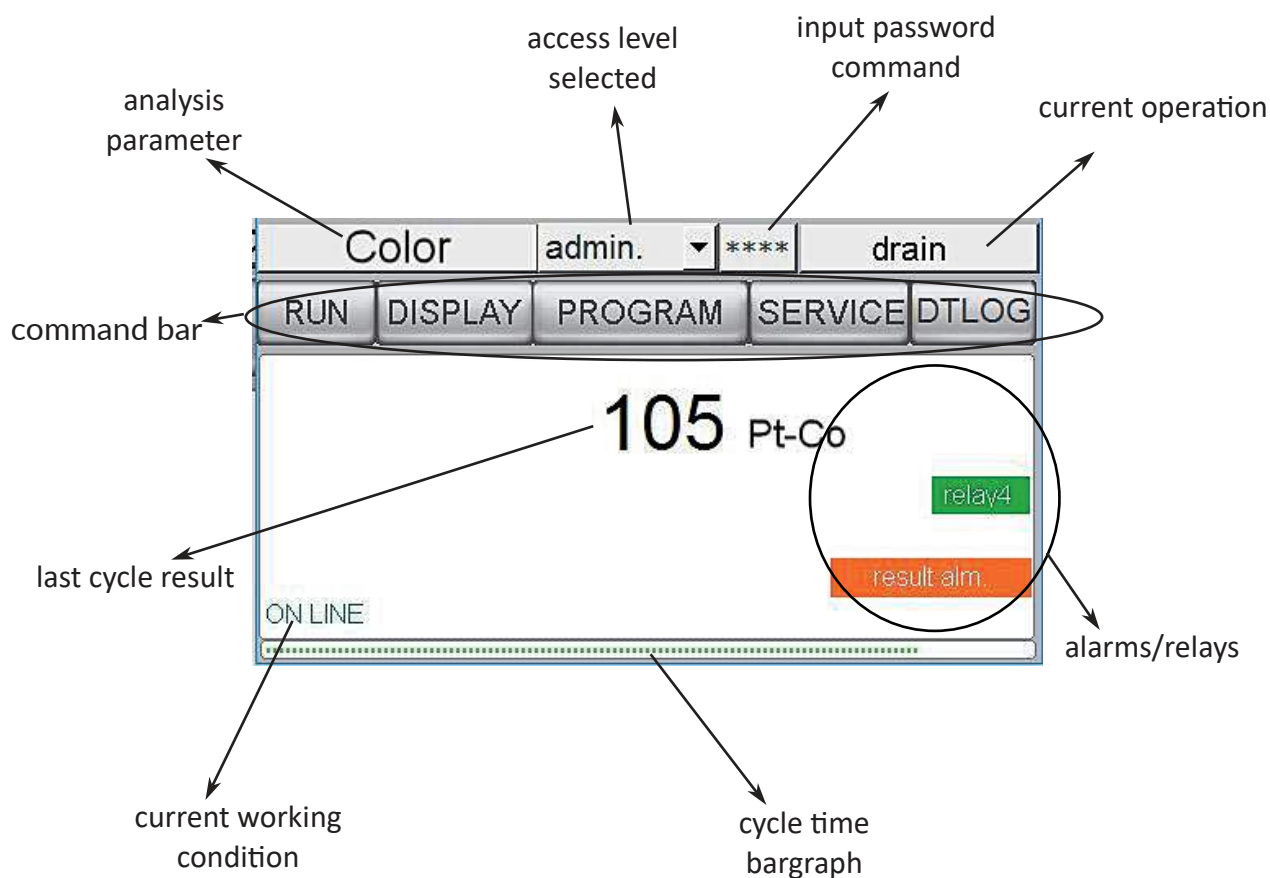

If the device was set to analyse 2 channels, last-cycle result values will be displayed.

According to the display logic:

- if the commands are idle for 1 minute, the result page will be displayed;
- if the commands are idle for 3 minutes, the backlight of the screen will turn off you can restart the display at any time by touching any point on the screen.



Result page (shown after 1 minute of touchscreen inactivity)

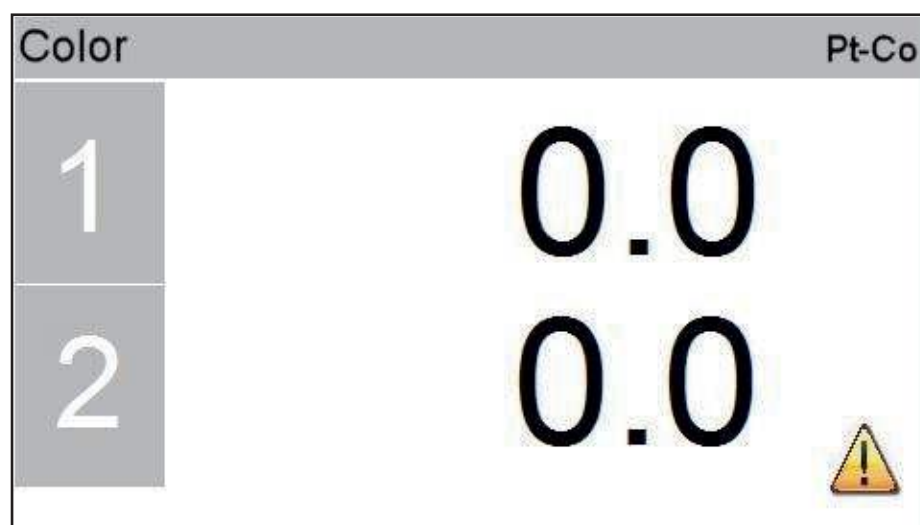

Dual stream result page

4.2 Knowledge of the standard components

In addition to know about the main screen, before using the analyzer, you should identify its standard components.

To do this, open the lower compartment.

Here is what you will see:

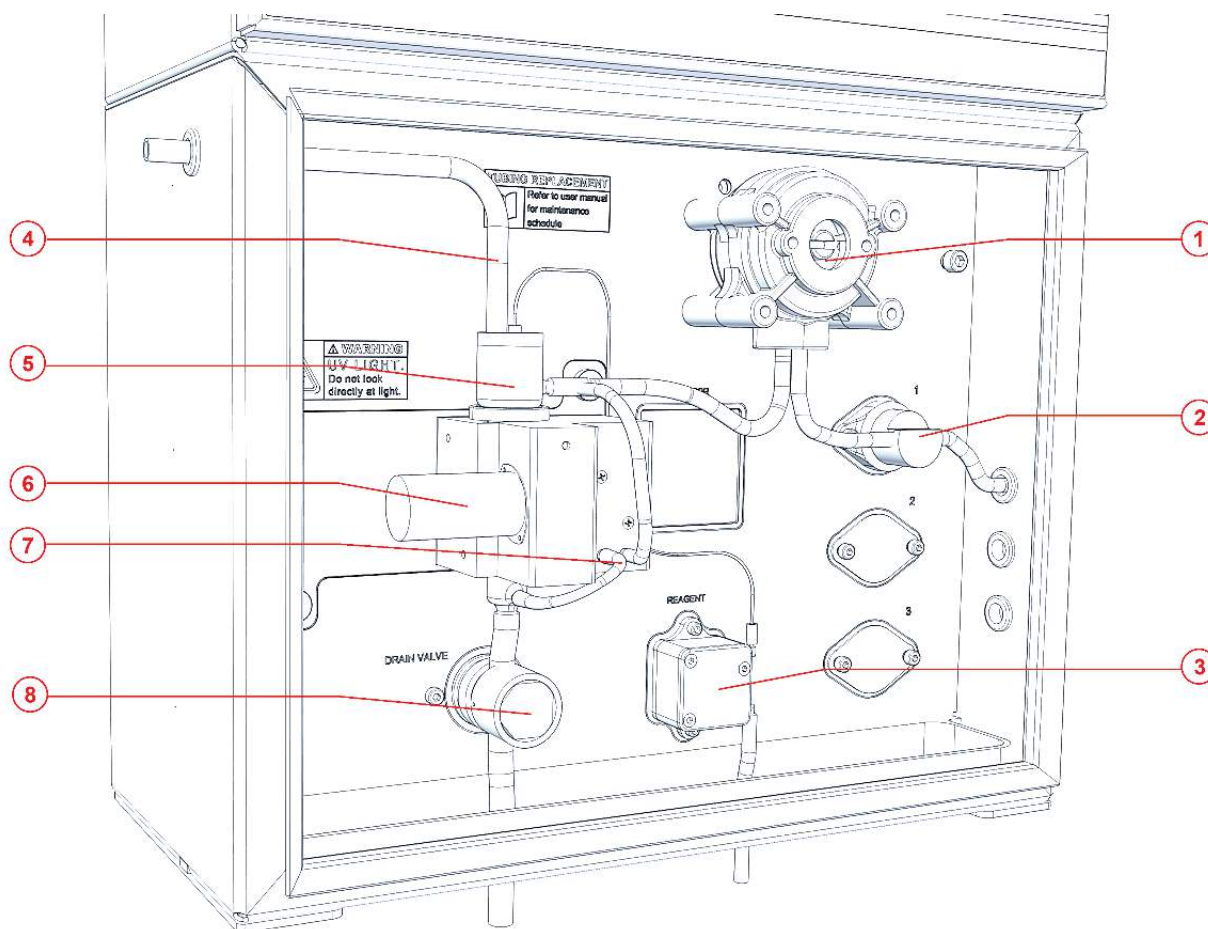

1	SAMPLING PUMP
2	SAMPLE SOLENOID VALVE
3	CLEANING/REAGENT PUMP
4	MEASURING CELL VENT TUBING
5	MEASURING CELL
6	XENON U.V. LAMP
7	MIXING PUMP
8	DRAIN SOLENOID VALVE

4.3 Optional components

Some optional components can be added in the lower hydraulic compartment depending on the application and the measuring range

Here is what you can eventually see:

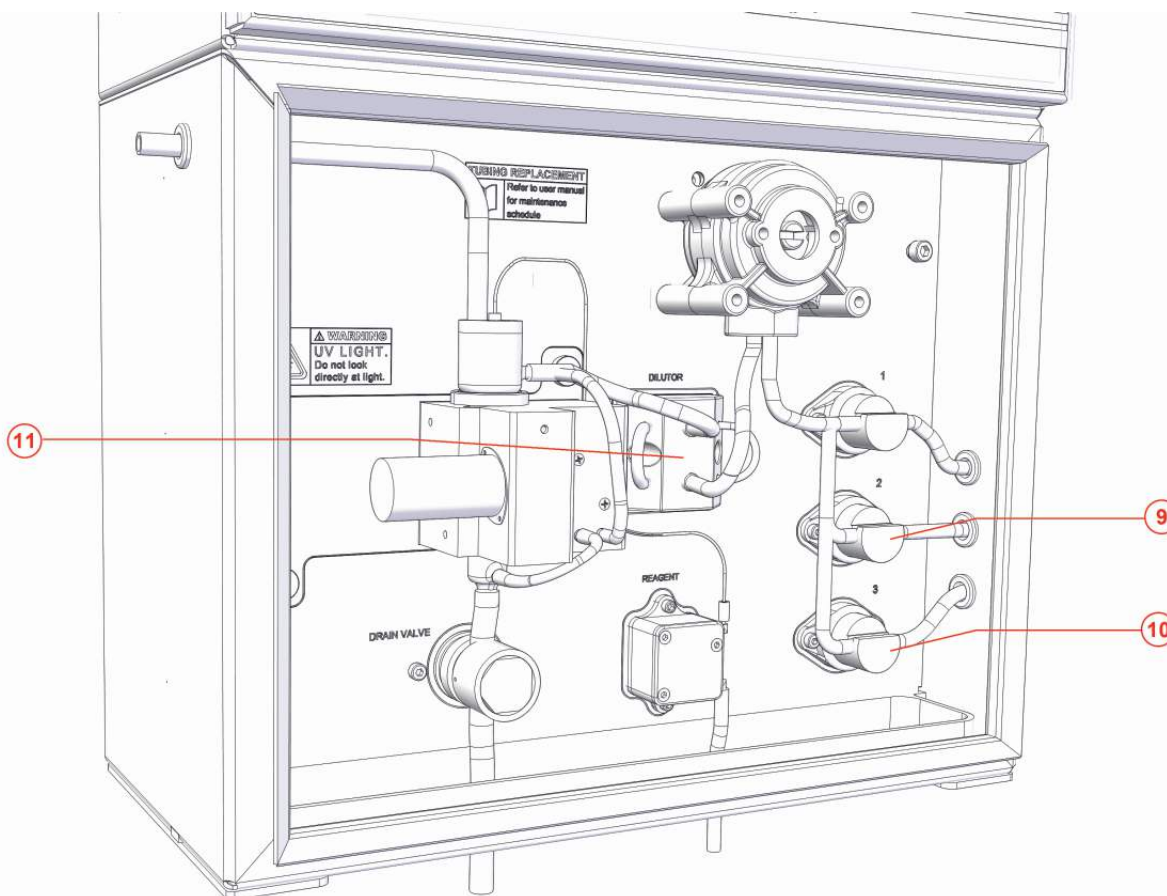

9	VALVE 2 (for second stream, autocalibration or dilution water)
10	VALVE 3 (for autocalibration or dilution water inlet)
11	DILUTOR block

4.4 Take knowledge of the component function

By activating the commands, the following operations can be performed:

- WAIT no operation
- RINSE #1 the sampling pumps, valve 1, the mixer pump and the cell drain valve are activated so that the liquid connected to valve 1 can be sucked and drained. This helps conditioning the sample line 1 by removing any liquid residues in the tube.
- RINSE #2 operation similar to the one above, but through activation of valve 2
- RINSE #3 operation similar to the one above, but through activation of valve 3
- DRAIN the exhaust valve and the recirculation pump are opened so as to empty the measuring cell
- SAMPLE#1 the sampling pump, valve 1 and the mixer pump are activated so as to suck the liquid of line 1 and fill the measuring cell
- SAMPLE#2 operation similar to the one above, but through activation of valve 2
- SAMPLE#3 operation similar to the one above, but through activation of valve 3
- MIX the liquid in the reading cell is mixed and sucked from the bottom and sent back to the top
- LOOP ON the dilutor valves are activated to retain the amount of liquid to be diluted in the sampling pipe section
- LOOP OFF the dilutor valves are turned off to release the liquid previously retained in the LOOP ON phase
- LAMP ON the sequence of 21 flashes at the end of which the results of the sensors are calculated is activated (min. 7 secs)
- REAG the cleaning pump is activated

4.5 Manual activation of functions

It is possible to observe and distinguish, after opening the lower door, the various operations by activating them manually.

This may help when turning on the analyzer for the first time or even later, during maintenance operations.

For example, it is advisable to use this procedure to verify the correct arrival of the sample, after connecting the different parts, or check the correct operation of the drain.

Proceed as follows:

- 1- from the main page, select the SERVICE user and enter the password 1111 followed by ENT;

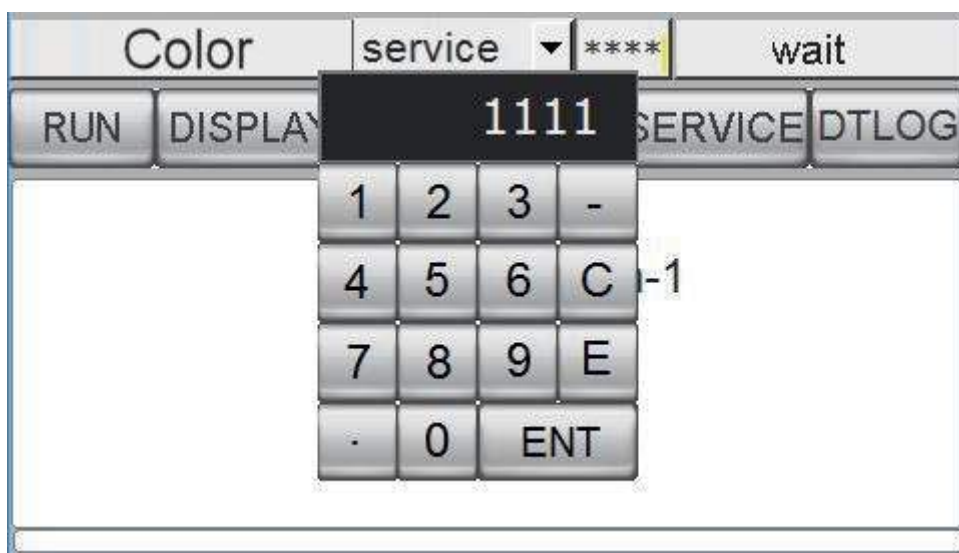

- 2- select the command DISPLAY followed by MANUAL

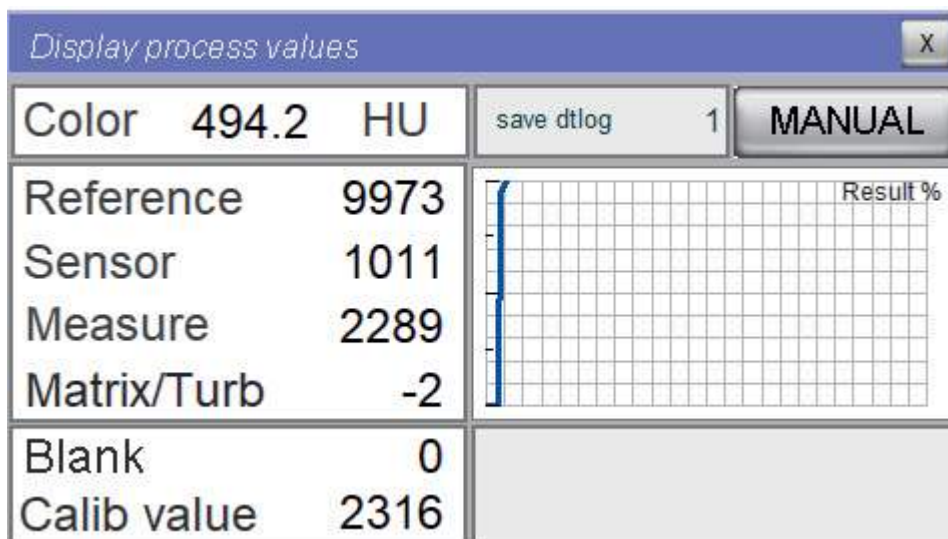

3- from the drop-down menu, select an operation from the previous list of component functions

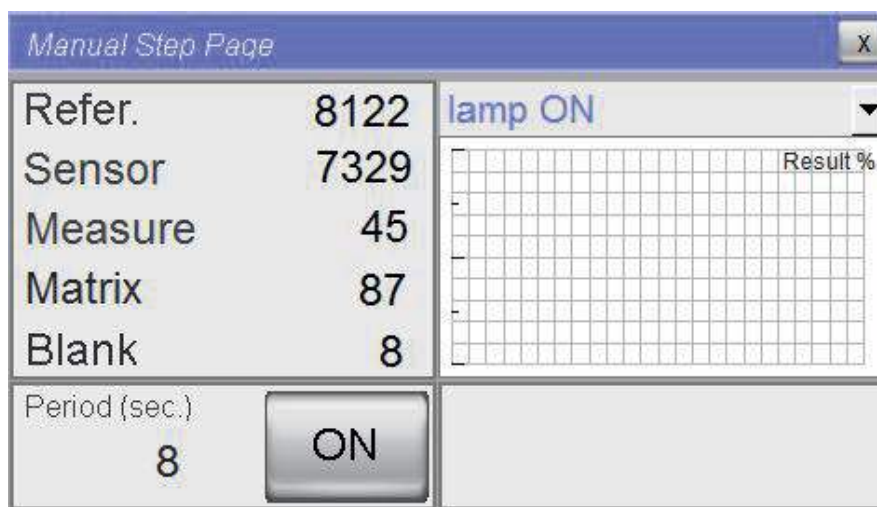

4- on the left, set the activation period in seconds by pressing the previous value and setting the desired time with the keyboard that will appear, followed by ENT

5- press ON and watch the operation reaching the end of the set time before the machine turns off.

4.6 Single cycle, online cycles and extra cycle

The instrument executes analysis cycles consisting of several sequential operations following his cycle step program.

Apart from the function operated by components, there are others like calculation or data managing (see 4.13).

At each end of a cycle a new result value is calculated, shown and transferred out by mean of an analog output or by the serial communication (Modbus protocol)

Under the Online condition the cycle is repeated until the online command is on, between cycles a waiting period can be set.

At a default frequency a cycle that follows a different programming can take place instead of the standard cycle. This is the EXTRA cycle that can be programmed for autocal, cleaning.

For the waiting time setting and the Extra cycle frequency, see the manual section SETTINGS.

The single cycle, meaning one single execution of a cycle is only started by a manual command. Consider that the cycle includes the final waiting period.

4.7 Starting a single cycle

Once performed all the checks required, the first analysis cycle can be started. To do that, press RUN so that the following page can be displayed



Pressing the SINGLE key a single cycle will be performed, once completed (final waiting period included) the analyzer will stop.

4.8 Starting an extra cycle

Similarly to the above, by pressing EXTRA a cycle following special programming for extra cycles will be executed. The analyzer will stop once the cycle is completed.

Please note that if on the SETTINGS page the frequency of extra cycles is set to 0 (zero) you will not even be able to run a manual cycle, and the EXTRA key will be turned off.

Similarly, if another (single or online) process is in progress, it will not be possible to launch a new process until the end of the previous one.

4.9 Starting online operation

From the same page of RUN commands, by pressing START ONLINE the following sequence will be activated: cycle-wait-cycle-wait-extra cycle (if activated and according to the set frequency)-wait-cycle... and so on.

One of the following events must occur to stop the online operation:

- the EMERGENCY STOP key is pressed, resulting in immediate stop.
- the ONLINE key is off, thus causing the machine to stop at the end of the cycle.

4.10 Example of measuring and extra cycle programming

The measurement cycle is a sequence of 25 steps, and an operation (as well as a duration in seconds) is assigned to each of them in the cycle programming (PROGRAMMING).

The same happens for an extra cycle which, however, consists of 15 steps and has a different programming (EXTRA).

Although some changes and customisation are allowed, with the help of the manufacturer’s technical support, the programming (operation + duration in sec.) for the different types of measurement cycles is the following (default):

SINGLE STREAM			DUAL STREAM		
1	RINSE # 1	10	RINSE # 1		10
2	SAMPLE # 1	9	SAMPLE # 1		9
3	DRAIN	3	DRAIN		3
4	SAMPLE # 1	9	SAMPLE # 1		9
5	MIX	10	MIX		10
6	WAIT	10	WAIT		10
7	LAMP ON	10	LAMP ON		10
8	CALCULATION # 1	2	CALCULATION # 1		2
9	DATALOG	2	RINSE # 2		10
10	DRAIN	3	SAMPLE # 2		9
11	WAIT	0	DRAIN		3
12	WAIT	0	SAMPLE # 2		9
13	WAIT	0	MIX		10
14	WAIT	0	LAMP ON		10
15	WAIT	0	CALCULATION # 2		2
16	WAIT	0	DATALOG		2
17	WAIT	0	DRAIN		3
18	WAIT	0	WAIT		0
19	WAIT	0	WAIT		0
20	WAIT	0	WAIT		0
21	WAIT	0	WAIT		0
22	WAIT	0	WAIT		0
23	WAIT	0	WAIT		0
24	WAIT	0	WAIT		0
25	WAIT	(page SETTING)	WAIT		(page SETTING)

Below is the standard programming of dilution methods.

PLEASE NOTE THAT

In this example, filling times (in seconds) refer to the 12 mm cell (corresponding to 9 seconds), while for the 6 mm cell they correspond to 3 seconds.

SINGLE STREAM + DILUTION			DUAL STREAM + DILUTION		
1	LOOP ON	1	LOOP ON	1	
2	RINSE # 1	15	RINSE # 1	15	
3	LOOP OFF	1	LOOP OFF	1	
4	SAMPLE # 2 (WATER)	9	SAMPLE # 3 (WATER)	9	
5	DRAIN	5	DRAIN	5	
6	SAMPLE # 2	9	SAMPLE # 3	9	
7	DRAIN	5	DRAIN	5	
8	LOOP ON	1	LOOP ON	1	
9	SAMPLE # 2	9	SAMPLE # 3	9	
10	LOOP OFF	1	MIX	20	
11	MIX	20	LAMP ON	10	
12	LAMP ON	10	CALCULATION #1	2	
13	CALCULATION #1	2	RINSE # 2	15	
14	DATALOG	2	LOOP OFF	1	
15	DRAIN	3	SAMPLE # 3	9	
16	SAMPLE # 2	9	DRAIN	5	
17	WAIT	0	LOOP ON	1	
18	WAIT	0	SAMPLE #3	9	
19	WAIT	0	MIX	20	
20	WAIT	0	LAMP ON	10	
21	WAIT	0	CALCULATION #2	2	
22	WAIT	0	LOOP OFF	1	
23	WAIT	0	DRAIN	3	
24	WAIT	0	DATALOG	2	
25	WAIT (page SETTING)		WAIT (page SETTING)		

For an EXTRA cycle, even though it is usually characterised based on the sample, after a first operation period, to assess the frequency and dosage of the cleaning reagent, please refer to this default cycle below.

In the case of automatic calibration of the absorbance value, replace the CALIBRATION operation with the one referred to as BLANK.

EXTRA CYCLE (CLEANING + BLANK)		
1	RINSE # 2 (WATER)	15
2	SAMPLE # 2	7
3	REAG	100
4	MIX	120
5	DRAIN	5
6	SAMPLE # 2	9
7	DRAIN	5
8	SAMPLE # 2	9
9	DRAIN	5
10	SAMPLE # 2	9
11	DRAIN	5
12	SAMPLE # 2	9
13	LAMP ON	10
14	BLANK	2
15	DRAIN	3

Here below an example of how it looks a programming page, accessible by the ADMIN user:

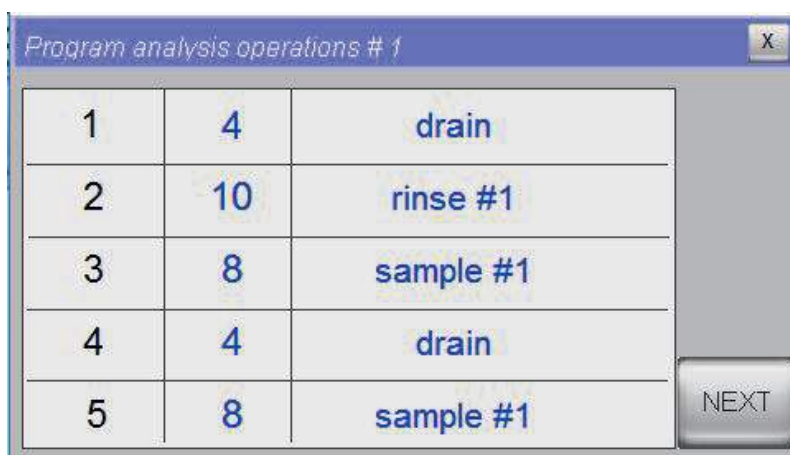

And, similarly (green background instead of yellow), the EXTRA programming page

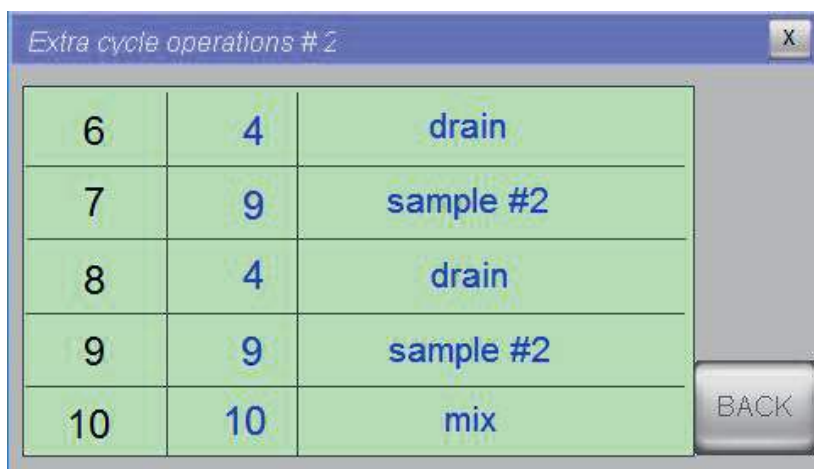

Extra cycle operations #2		
6	4	drain
7	9	sample #2
8	4	drain
9	9	sample #2
10	10	mix

the steps are shown on more pages, that can be scrolled by using

NEXT and **BACK** keys

4.11 Emergency stop

Pressing the EMERGENCY STOP key on the RUN page, any operation will be immediately stopped.

At this point, you must restore the key operation (now set to RESET) from the RUN page.

4.12 Loss of sample

The analyzer accepts two sample presence level contacts (see 3.8) a having the following operating logic:

- Single channel analyzer with sample reservoir level contact. If the absence of the sample is detected during online operation, at the end of the current cycle the analyzer will stop and until the sample level is detected.

It will restart automatically.

- Dual channel analyzer (dual stream) with 2 level contacts on the two sampling reservoirs.

Only if both contacts indicate the absence of the sample the analyzer will stop until at least one of the two contacts is restored.

In any case, in the absence of one or two samples, the CALCULATION #1 or CALCULATION #2 operation corresponding to the missing sample will not be performed.

As a result, the previous analysis value will not be updated and will remain unchanged, to avoid false analysis values, performed with an empty measurement cell.

4.13 Logic operation and display page

In order to complete the knowledge of the analyzer, below the list of those functions that are not related to a specific component, but, when activated, executes calculation and data processing.

ZEROING	this operation requires a software authorization to be executed, it's a kind of factory setting only necessary when replacing optical parts (lamp, filter or detector)
CALCULATION CH1	the calculation of the stream 1 result is performed, and addressed to the analog output 1
CALCULATION CH2	the calculation of the stream 2 result is performed, and addressed to the analog output 2
CALIBRATION	the calculation of the calibration factor is performed starting from the last raw values found. Note that it works on the primary calibration only, while the process calibration has to be done manually only.
BLANK	when executed, the zero offset is stored, therefore the command has to be given after a few cycles done with pure water
DATALOG	a new record reporting the last values is stored in the Datalogger

Below the meaning of the values on the DISPLAY screen

ABS: last absorbance result expressed in m^{-1}

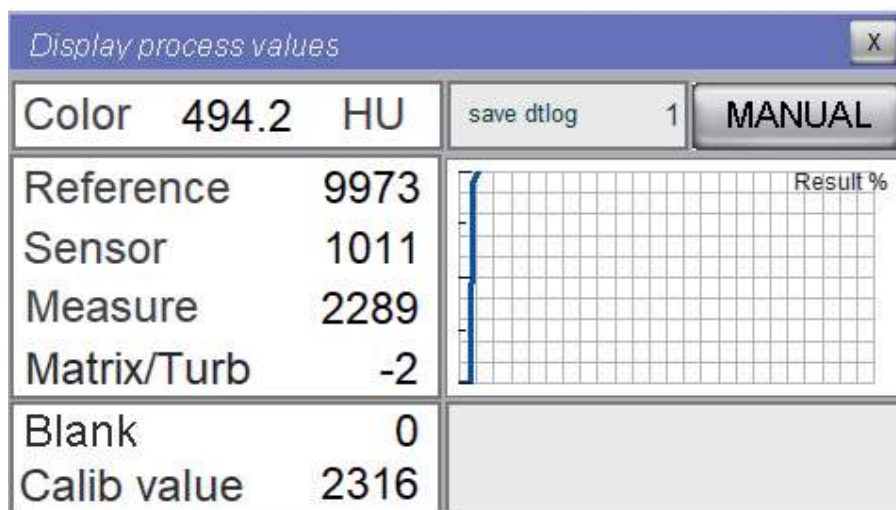

Reference: reference photodiode sensor value expressed as sensor unit with a 0-10000 scale, obtained during the last flashes series.

Sensor: sensor photodiode value expressed as sensor unit with a 0-10000 scale, obtained during the last flashes series.

Measure: value obtained from the last absorbance measurement expressed as sensor unit.

Matrix/turb: value expressed as sensor unit related to turbidity, sample colour or cell dirt obtained from the last measurement performed.

Blank: basic calibration offset, the number shown is the value expressed as sensor unit attributed by the last Blank calibration.

Calib value: calibration value, the number shown is the one (expressed as sensor unit) from the last calibration .

5 - SETTINGS

5.1 Settings page

Pressing PROGRAM from the command bar the below window will be displayed

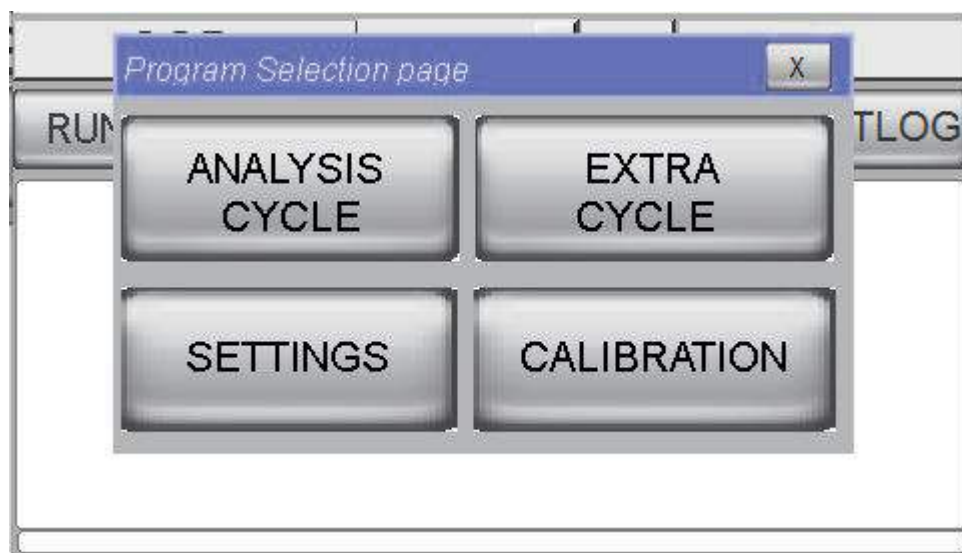

Please note: only ADMIN users will be able to see the full page in this mode, while SERVICE users will only see the two lower keys, and if the user password is not recognised, only the SETTINGS key will be displayed.

Select SETTINGS so that the following page can be displayed:

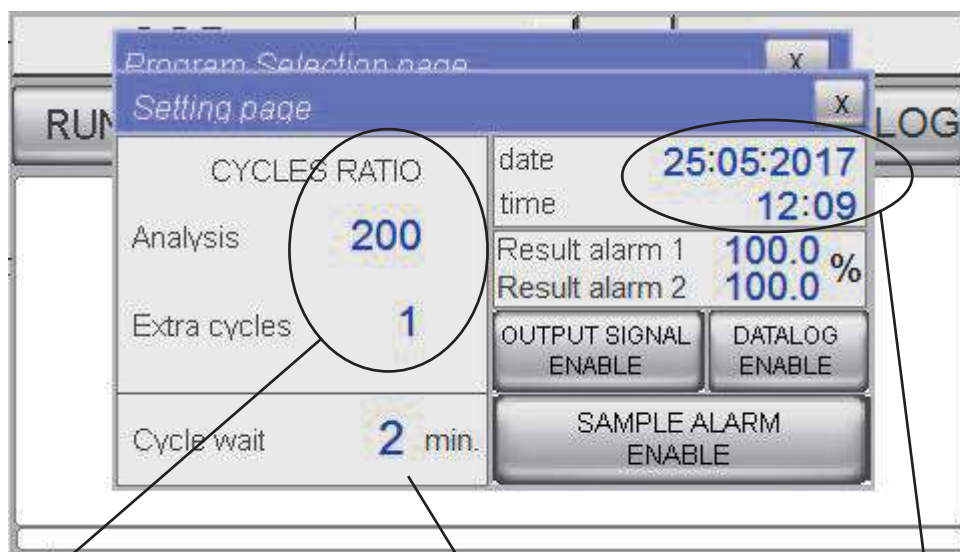

extra cycle frequency.
Example 1 cycle extra
every 200 normal
cycles

waiting period between
two cycles

date and time
setting

Setting the measure alarm value expressed in fullscale percent. For a measured value above the Result Alarm 1 (and 2 if dual) threshold settings, a relay will be triggered if programmed as Result Alarm (par 5.3).

When pressed (disable) the analog signal is frozen to the last value

When pressed (disable) the data recording (datalogger) is paused

when pressed (disable) the level contacts are not active

For numeric settings, press in the screen area displaying the numeric value you want to set/change to access the keyboard. After setting the number required, close the keyboard by pressing ENT.

ENABLE/DISABLE commands are lever key switches. They are usually set during maintenance or calibration operations, to avoid false signaling or recording.

Please note: in case of power failure the DISABLE setting of these keys may return to ENABLE.

5.1 Service page

The configurations on the SERVICE page are important when using the machine, while they are not widely used after the machine start-up, therefore to access this page the ADMIN user must be recognized through its password.

If required, ask the manufacturer for the ADMIN password and write it down in a note.

ADMIN PASSWORD:

After entering the ADMIN log-in information in the command bar, the SERVICE key will appear, which will open the next page.

Service #1			
Version 240517 -13	Unit Pt-Co	Method Color	Ext. Input On line
Back light delay min. 180	Ch1 process ratio 1.00	fullscale 200	Relay #1 loss of sample 1
Modbus slave i.d. 12	Ch2 process ratio 1.00	fullscale 200	Relay #2 loss of sample 2
Output simul. 0 %	Cal. min 0	Cal. max 2000	Relay #3 Fault Alarm
Manual Blank 3	Turb max 100	Blank toler. 50	Relay #4 Result Alarm

Here the list of the service page possible settings:

NAME	INPUT	MEANING
Version	none	software version display and plc
Backlight delay min	keyboard	touchscreen inactivity time (minutes) before the back light goes off
Modbus slave i.d.	keyboard	RS485 modbus node number
Output simul.	keyboard	Only working when the command OUTPUT SIGNAL DISABLE in the Setting page is pressed The analog signals will be set according the % simulated value
Manual Blank	keyboard	Manual set of the Blank value

Unit	scrolling	user can choose one of the following units: m-1 cm-1 mg/l ppm AbsU
Method	scrolling	user can choose one of the following methods ABS Color Pt-Co Hazen
Ch1 Process ratio	keyboard	ratio process/absorbance channel 1
Ch1 full scale	keyboard	full scale analog signal channel 1
Ch2 Process ratio	keyboard	ratio process/absorbance channel 2
Ch2 full scale	keyboard	full scale analog signal channel 2
Cal min	keyboard	calibration alarm low limit expressed in milliAbs unit
Cal max	keyboard	calibration alarm high limit expressed in milliAbs unit
Turb max	keyboard	turbidity high alarm limit expressed in milliAbs unit
Blank tol	keyboard	Blank alarm high limit expressed in milliAbs unit
Remote input	on/off	if ON the remote input will be activated. When input is ON the analyzer goes ONLINE
Relay 1	scrolling	The user can choose one among the below list: -Result alarm -Loss of sample 1 -Loss of sample 2 -Fault alarm -Cycle command -Latch/Unlatch -Power on -Optic failure -Calibr alarm
Relay 2		
Relay 3	scrolling	The user can choose one among the below list: -Result alarm -Loss of sample 1 -Loss of sample 2 -Fault alarm
Relay 4		

5.3 Relays

The 4 external digital contacts (relays) must be configured, as specified in paragraph 5.2, to assign a function to each of them.

These are the functions:

RESULT ALARM	The relay so configured is activated when the last measured value exceeds the set limit. Once the value is within the limits, the alarm is reset.
LOSS OF SAMPLE 1 , 2	the relay so configured is activated when the low contact of the recirculating tank indicates the absence of a sample (1 or 2)
FAULT ALARM	The relay is activated in case of forced stop of the analyzer as a result of an emergency stop.
CYCLE COMMAND	The relay is activated by a command in the cycle programming and can be used for external components and accessories (e.g. external sampling pump, or end/start of analysis contact, etc.)
LATCH/UNLATCH	The relay changes its status according to cycle programming (for example, it is activated at a point in the cycle and is deactivated at another point).
POWER ON	The relay is always active when the analyzer is electrically powered.
OPTIC FAILURE	The relay is activated in the presence of a malfunction alarm involving optical equipment
CALIBR ALARM	The relay is activated when there is an out-of-limits calibration alarm

6 - ANALYSIS CYCLE AND CALIBRATION

6.1 About the method

The analyzer is manufactured and delivered to measure the color of a water sample as from Absorbance @ 350 nm wavelength.

Therefore, at the end of the first measurement cycle, the value resulting from the calculation is expressed in Pt-Co (or Hazel) measurement units of Color, following the calibration done with standard solutions.

The machine is calibrated at the factory using a color standard solution (Pt-Co standard) as described below:

COLOR MOTHER STANDARD SOLUTION 500 Pt-Co units

- Fill a 1000mL graduated flask to 200mL with demineralized water.
- Add 100 mL of concentrated 37% hydrochloric acid while stirring the solution.
- Add 1.00 g of cobalt chloride $\text{CoCl}_2 \cdot 6\text{H}_2\text{O}$ (equivalent to 250 mg of metallic Co)
- Mix the solution until is completely dissolved
- Add 1.246 g of potassium chloroplatinate K_2PtCl_6 (equivalent to 500 mg of metallic Pt)
- Add a little bit of demineralized water and then make up the volume to the gauge line with demineralized water (1000 mL).

By diluting an appropriate volume of the mother solution with DI water, various calibration solutions with a known Pt-Co units may be prepared.

For example: diluted solution 100 Pt-Co units

- To obtain 1L of a 100 Pt-Co units standard solution fill a 1000 mL graduated flask to 2/3rds capacity with demineralized water.
- Add 200mL 500 Pt-Co mother solution.
- Make up the volume to the gauge line with demineralized water (1000 mL).

Depending on the cell size different concentrations can be used.

This primary calibration can be performed at any time, automatically (simply programming the Calibration into the Extra Cycle) or manually (using calibration page). A standard solution should be used to perform primary calibration.

In order to adjust and align the result to process conditions and/or to take into account the dilution of the sample, a Process Calibration will follow.

Initially the alignment factor equals to 1, so the final reading will be calculated based on the Primary Calibration only.

Here is described how to manually perform the primary calibration (blank and full scale value using a standard solution).

6.2 Primary calibration

Proceed as follows:

- 1 remove the tube from the sample recirculation tank through the connector at the end of the pipe coming out from the right side of the machine;
- 2 insert another piece of noprrene tube (to keep it clean from impurities and dust) from which the calibration liquids will be sucked;
- 3 stop the analyser by removing the **START ONLINE** command from the **RUN** window;
- 4 run 3 to 4 analysis cycles using DI water ;
- 5 at the end of the last analysis, and after making sure that you get low values from the DISPLAY menu (1 to 30 abs) enter the Service User password;
- 6 select **PROGRAM** and then **CALIBRATION** so that the calibration page can be displayed;



- 7 press and hold the BLANK button until the page is closed, this way the last calculated absorbance value will be acquired;
- 8 replace the zero bottle with a bottle containing a standard of known concentration corresponding to the full scale of the analyzer;
- 9 run 3 to 4 cycles with **SINGLE** manual start;

11 As already done before, access the **CALIBRATION** page and hold **MANUAL CAL** until the page is closed.

Verify the absence of calibration alarms.

6.3 Process Calibration

As mentioned in par 6.1, the primary calibration done with standard solution often should be followed by a Process Calibration to align to process conditions.

Below 2 different ways to proceed with Process Calibration:

1 - calculate an average ratio value extracted from a series of comparative instrument / laboratory values.

sample day 1 instrument reading = 55 laboratory = 60 ratio = 1.09

sample day 2 instrument reading = 63 laboratory = 74 ratio = 1.17

sample day 3 instrument reading = 62 laboratory = 70 ratio = 1.13

sample day 4 instrument reading = 52 laboratory = 58 ratio = 1.11

average ratio 1.12

Depending on the degree of variability of the different individual ratios found, a more or less wide range of correlations should be considered.

The ADMIN user, then, by accessing the **SERVICE** page, can manually set the value found in the CH1 Process ratio field (or CH2 if considering a dual channel sample of a dual stream device).

2 Take a daily average sample, or even a punctual sample, if it can represent the process variability, and perform a laboratory analysis to determine the value expressed in the desired parameter.

Then, perform 2 to 3 cycles on the same sample to obtain a stable absorbance value.

Now, from the **CALIBRATION** page (see 6.2) the SERVICE user can set the laboratory value in the Process Value 1 field (or two, if using channel 2 of a dual stream device) and then press and hold the **PROCESS CAL 1** key, until the page is closed.

Whether you have used Method 1 or Method 2, after the entering the correlation ratio (the default ratio is 1) the display and the analog output will refer to the new correlated value.

7 - DATA STORAGE

7.1 Datalogger page

At each end reading cycle, the main values of the run cycle are recorded

date hour result 1 result 2 Abs Matrix

This happens automatically unless the key  on the Settings page is enabled (see 5.1).

To view the recorded values, access the Result page using the  key on the main page, in the command bar.

After opening the page, select the required day using the top drop-down menu. The menu list includes all dates related to the days on which at least an analysis cycle has been recorded in the last 30 calendar days .

Dates prior to the 30th calendar day from the current date are deleted according to the first in, first out logic.

Alternatively, you can manually erase all stored data by pressing the  key.

7.2 Saving data on a USB memory device

To get a copy of the data contained in the archive on different days, open the top door and identify the USB port behind it, located on the bottom side of the operator panel.

After inserting a USB memory stick, which will be recognised by the panel (the USB DISK-1 caption will be appear on the screen just for one second), access the Result page and press and hold the SAVE USB key until the page is automatically closed.

The USB stick can be removed without any problems...

Inside it the analyzer will copy, if not already present, the Datalog folder containing as many files as the days memorized by the device.

These files are named yearmonthday.csv (e.g. 20170412.csv) and can be opened as normal spreadsheets (EXCEL).

8 - MAINTENANCE

8.1 Maintenance operation

Here below the list of the preventive maintenance operations:

COMPONENT	OPERATION	FREQUENCY
DRAIN VALVE	tubing replacement	every 4 months
VALVE 1	tubing replacement (if present in the configuration)	every 4 months
VALVE 2	tubing replacement (if present in the configuration)	every 4 months
VALVE 3	tubing replacement (if present in the configuration)	every 4 months
CLEANING PUMP	tubing and rollers replacement	every 8-12 months depending on duty
SAMPLE PUMP	tubing replacement (if present in the configuration)	every 4 months
MEASURE CELL	accurate cleaning	depending on process conditions

The frequency of listed maintenance operations can be modified in the case of heavy applications due to the nature of the material of the tubes, such as presence of sand grains or solvents in the sample.

Important: to replace pinch and peristaltic valve tubing, use only spare parts provided by the manufacturer to ensure proper sealing.

8.2 Dismounting the measure cell

This operation is necessary when the cell is dirty, for example when reading a high matrix value with clean water.

If the cell is often dirty and requires frequent manual cleaning, change time and frequency of the cleaning reagent, or the same chemical of the reagent used.

To disassemble the cell proceed as follows:

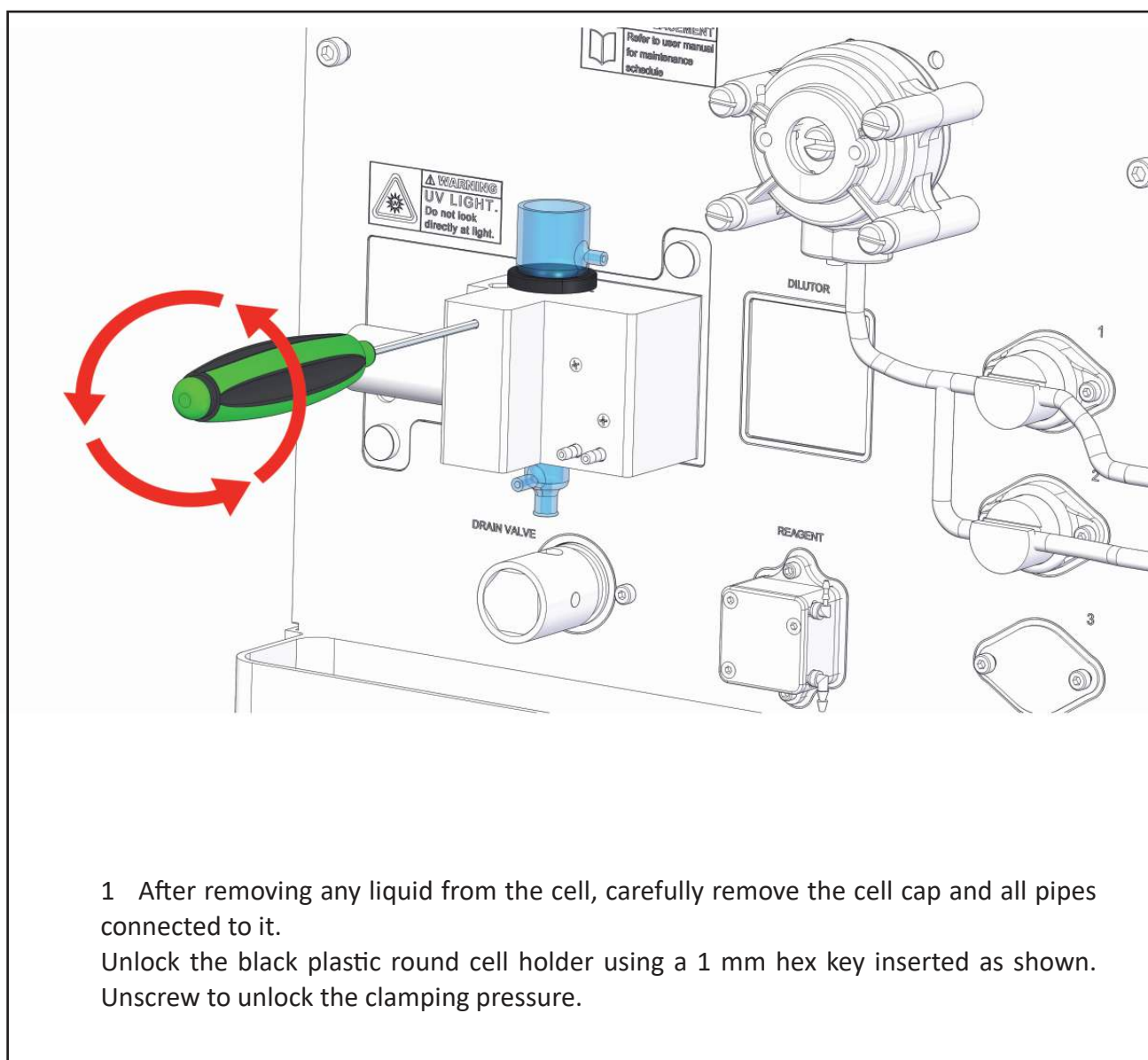

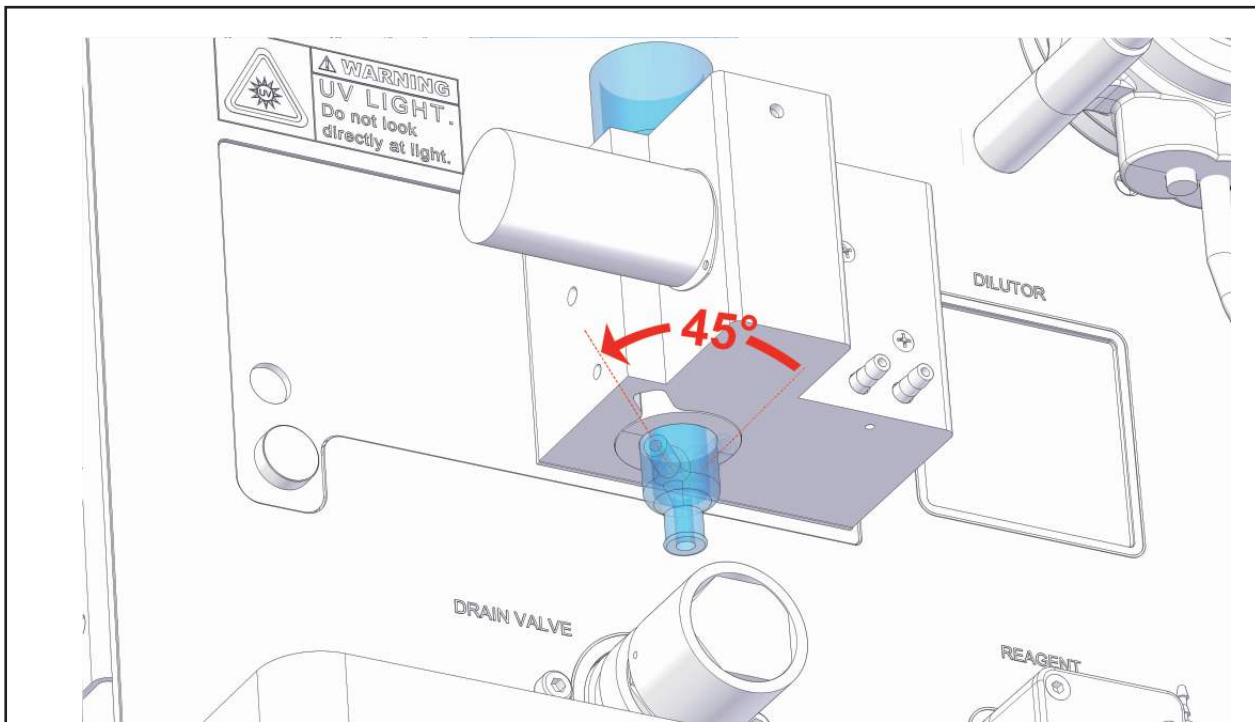

2 Rotate the quartz cell to align the side tang to the slot in the cell block, as shown.

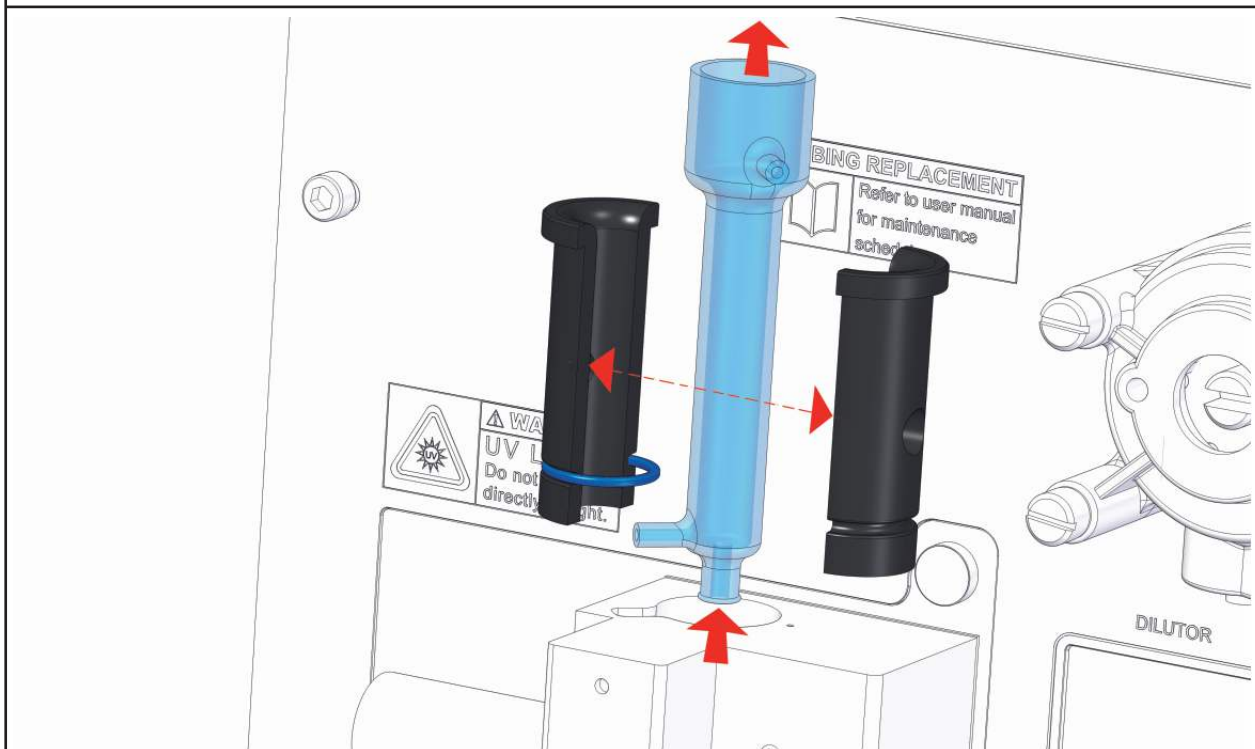

3 Remove the quartz cell by lifting it. Then open the two plastic shells after loosening the O-ring that keeps them sealed on the cell.

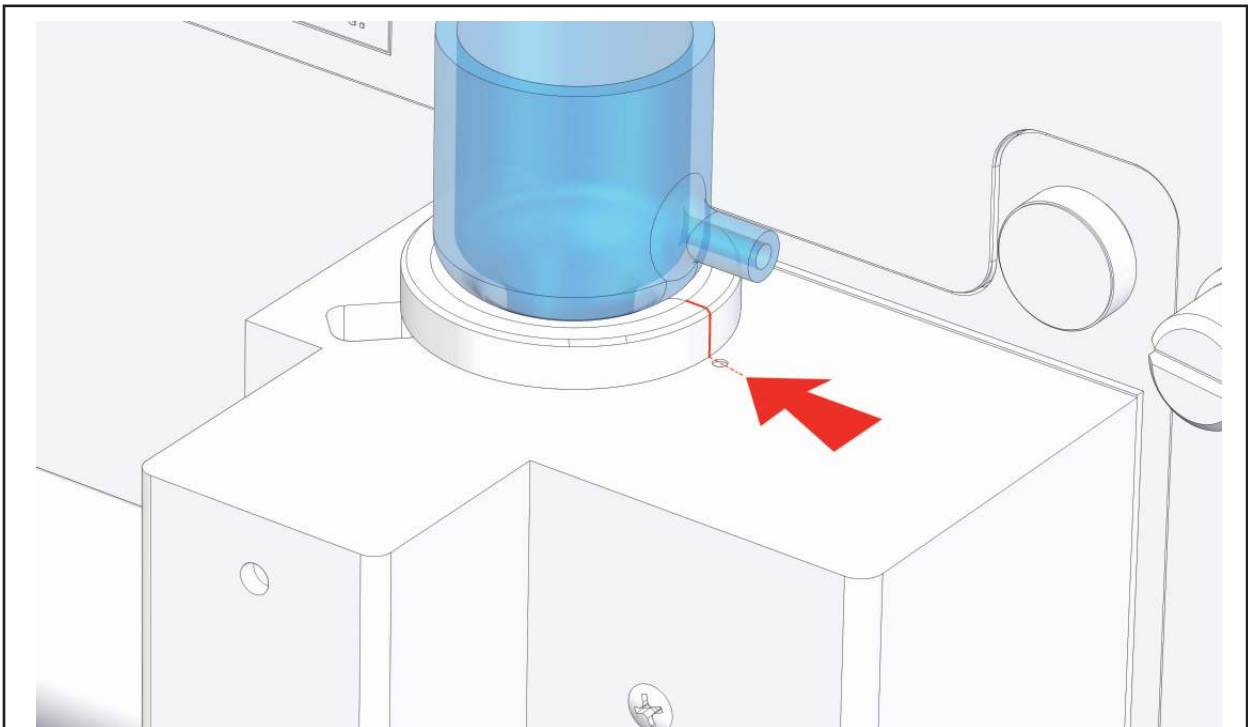

4 After cleaning the cell, reassemble the shells and the O-ring, place them back in the cell holder block and align the windows of the optical path, as shown above.

The separation line between the two black shells should be aligned with the reference point in the cell holder block, otherwise the light will not pass through the liquid as it should.

5 Fix the grub screw with a hexagonal wrench, while exerting a slight pressure so as not to force the plastic shells, but enough to prevent them from rotating.

6 Reconnect the tubes and put the cell cap where it was.

8.3 Reagent pump maintenance

This operation is necessary for the replacement of the cleaning reagent pump tube and rollers.

Although the tube ensures at least 70 hours of operation (it is possible to calculate the operating time considering the frequency of analysis and the operation intervals required by the cycle program), therefore it must be maintained and/or replaced at least every 8-12 months.

Use only the tube provided with the REAGENT PUMP KIT

The kit includes 3 spare tubes and one spare roller.

Proceed as follows:

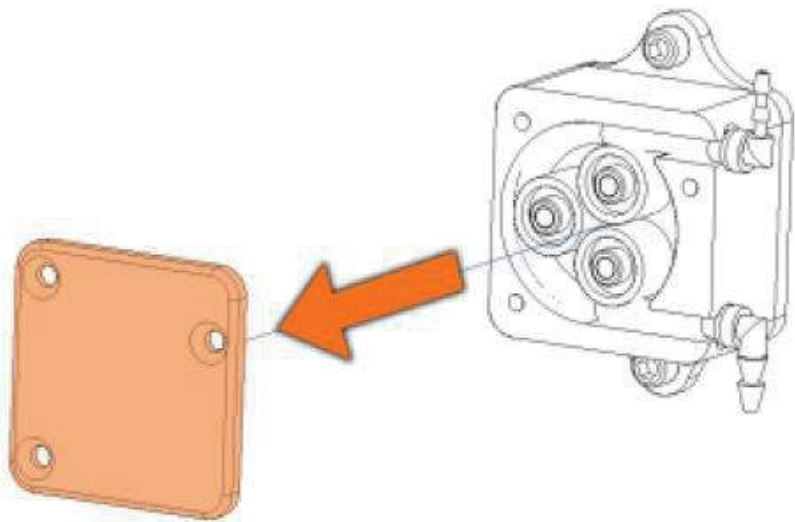

1 Remove the transparent cover by unscrewing the 3 fixing screws with a hexagonal screwdriver



PAY ATTENTION TO THE LIQUID
CONTAINED IN THE TUBE WHILE
REMOVING CONNECTIONS

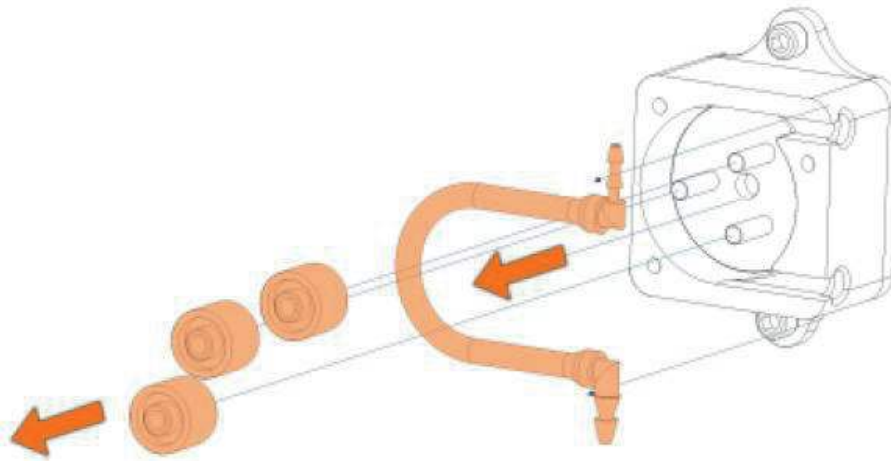

2 Remove the rollers and the tube to be replaced

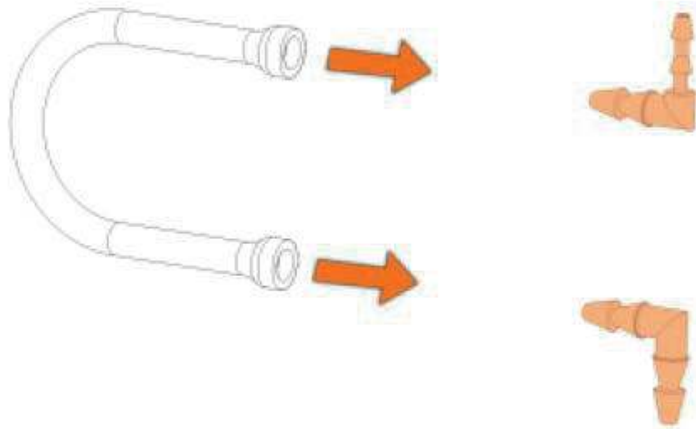

3 Disconnect the fittings and, if necessary, clean or replace them with those provided with the maintenance kit.

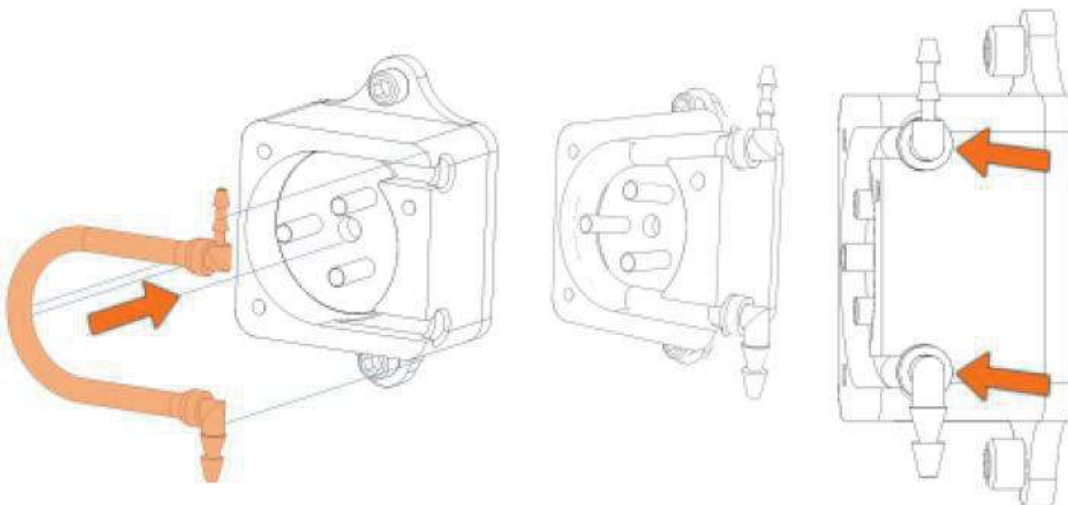

4 Insert the new tube using the fitting (pay attention to the size and direction)

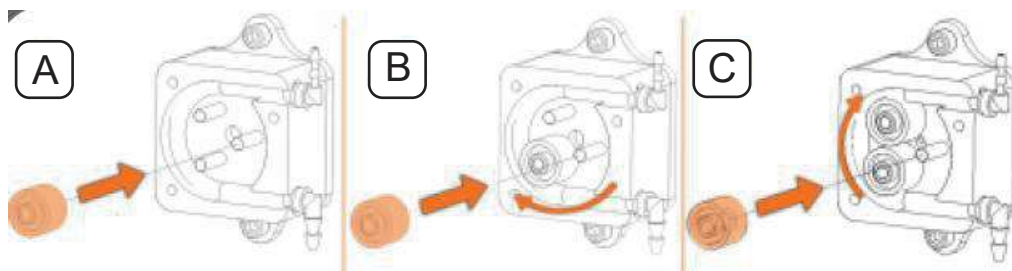

5 Insert the first roller, then operate the pump in manual mode for 1 second (DISPLAY - MANUAL page, see paragraph 4.5) and insert the second roller. Repeat the same operation for the third roller

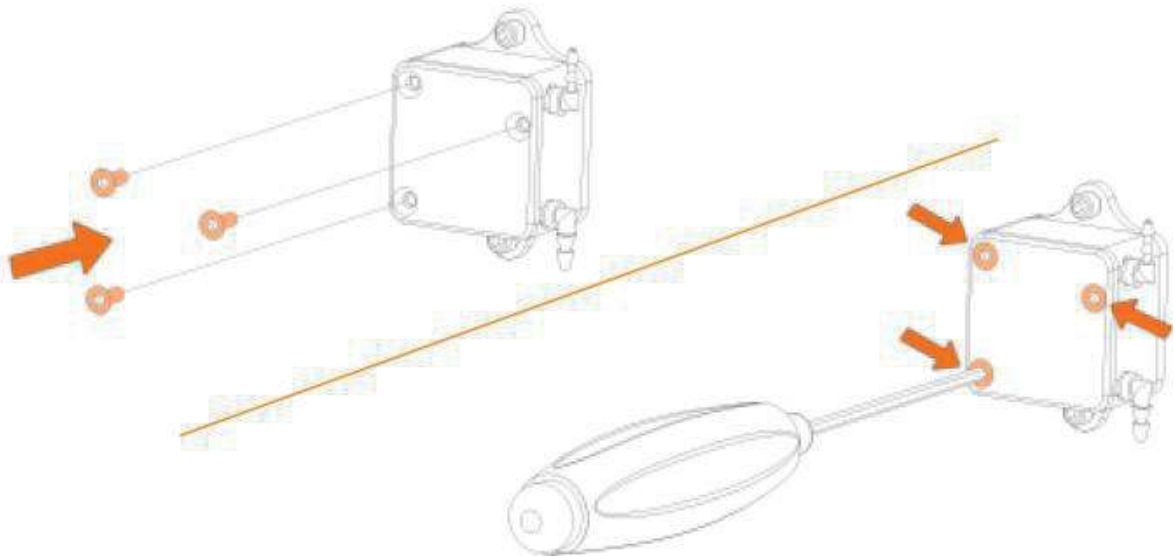

6 Close the transparent cover with the screws.

Reconnect the tubes and operate the pump in manual mode to fill the tube with the cleaning liquid coming from the bottle. Make sure that the liquid reaches the cell.

8.4 Alarms and troubleshooting

The analyzer diagnostic messages can be displayed in 3 different modes/levels.

1 - From the Results Page (the page that appears automatically after the touchscreen display has not been used for one minute)

The blinking warning symbol appears for each occurring event



2 - On the main page, on the right side, the following cumulative alarms are displayed in different colours:

- cal failure
- optic failure
- fault alarm
- result alarm
- no flow 1
- noflow

3 - On the bottom right of the display page there is some space for specific alarm messages

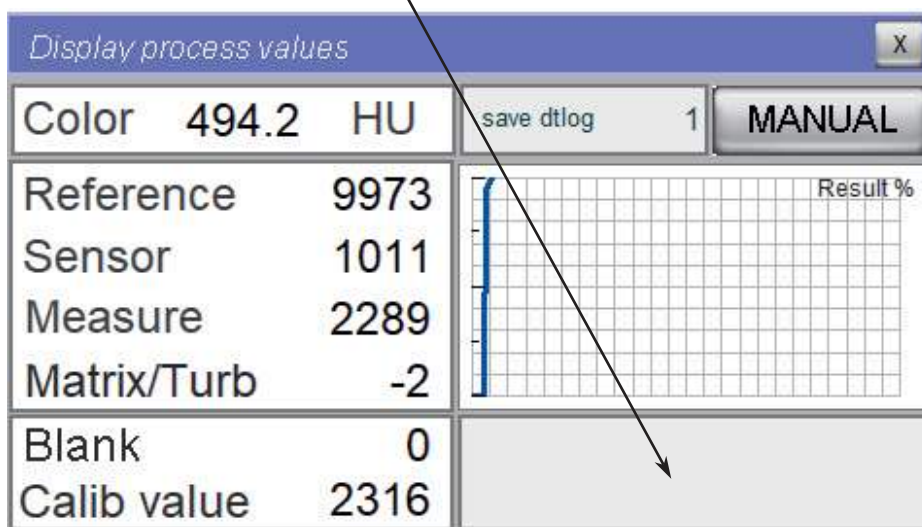

SIGNAL	GROUP	EFFECT
Sensor low	Optic alarm	analyzer stopped
Reference low	Optic alarm	analyzer stopped
Sensor high	Optic alarm	analyzer stopped
Reference high	Optic alarm	analyzer stopped
Sensor zeroing low	Optic alarm	analyzer stopped
Reference zeroing low	Optic alarm	analyzer stopped
Sensor zeroing high	Optic alarm	analyzer stopped
Reference zeroing high	Optic alarm	analyzer stopped
Flashes error	Optic alarm	analyzer stopped
Version error	Optic alarm	analyzer stopped
Turbidity high	Calibr error	only screen report/relay
Blank high	Calibr error	only screen report/relay
Calibr. error	Calibr error	only screen report/relay
Loss of sample 1	No flow 1	waiting/relay
Loss of sample 2	No flow 2	waiting/relay
Result alarm 1	Result alarm	waiting/relay
Result alarm 2	Result alarm	only screen report/relay
Fault alarm	Fault alarm	analyzer stopped

Below are the possible corrective actions required for the different alarm messages

<p>Sensor low</p> <p>Reference low</p> <p>Sensor high</p> <p>Reference high</p>	<p>Try resetting the analyzer from the RUN window, and run a clean water cycle. If necessary, check the cell cleanliness or align the cell shell.</p> <p>If the problem persists, contact the manufacturer's technical support, perhaps by attaching a photo of the DISPLAY page.</p>
<p>Sensor zeroing low</p> <p>Reference zeroing low</p> <p>Sensor zeroing high</p> <p>Reference zeroing high</p>	<p>This alarm is triggered following an attempt to zero the device out of the allowed limits.</p> <p>To set the device to zero, please refer to SERVICE MANUAL documents or contact the manufacturer's technical support.</p>
<p>Flashes error</p>	<p>The period of the LAMP ON operation was not enough to finish the 21 flashes expected, therefore no final calculations and means are available and, as a result, the abs and matrix result was not updated.</p> <p>You can try to activate manually (see 4.5) LAMP ON for 30 seconds and count the number of flashes.</p> <p>Check the electronics, and contact the manufacturer's technical support.</p>
<p>Version error</p>	<p>This signalling can only occur when the firmware is handled, or after replacing some electronic components with incompatible versions.</p> <p>Contact the manufacturer.</p>

Turbidity high	<p>The Matrix value is higher than the one set on the SERVICE page as the upper limit (see 5.1)</p> <p>Causes can be:</p> <ul style="list-style-type: none"> - the sample is actually too turbid - Non-liquid reading within the cell (Sample Level Enable set to Disabled on the SETTINGS page) or leaking cell drain. <p>After identifying the cause, you can remove it if possible or raise the alarm threshold, aware that the measurement error will be high.</p>
Blank high	<p>Blank calibration that has set a value higher than the acceptance values.</p> <p>Verify the cell cleanliness or the purity of the water used and try manually calibrate the Blank (see 6.2)</p>
Calibr. error	<p>Calibration that exceeded the maximum or minimum threshold.</p> <p>Check the standard used, the presence of liquid in the cell when performing the calibration and try manual calibration once again (see 6.2).</p>
Loss of sample 1 Loss of sample 2	<p>Try to identify the cause of the signalling by checking the presence of water, the level switch contacts, or the wrong setting of the level alarm disable key on the SETTINGS page.</p>
Result alarm 1 Result alarm 2	<p>High reading values, exceeding the limits set on the SETTINGS page.</p> <p>Verify with a comparison analysis if the sample is really exceeding the limits.</p>
Fault alarm	<p>If you see this message on the DISPLAY page, it means that the EMERGENCY STOP key has been pressed on the RUN page.</p> <p>To re-enable the key, it must be reset.</p>
***** values	<p>Whenever a value shown exceeds his range, then a ***** appears.</p> <p>Try to understand the reason why the value has reached that condition. Contact the manufacturer support if necessary.</p>

8.4 Electronics checks

When the metal cover is opened by removing the five fixing screws, then it's possible to check a few indicator LEDs, as indicated below

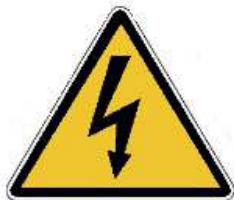

After removing the cover, do not touch the device with your hands or tools without removing the power supply! Switch on without the cover is only allowed for visual inspection.

LED CHECKS - NORMAL CONDITION

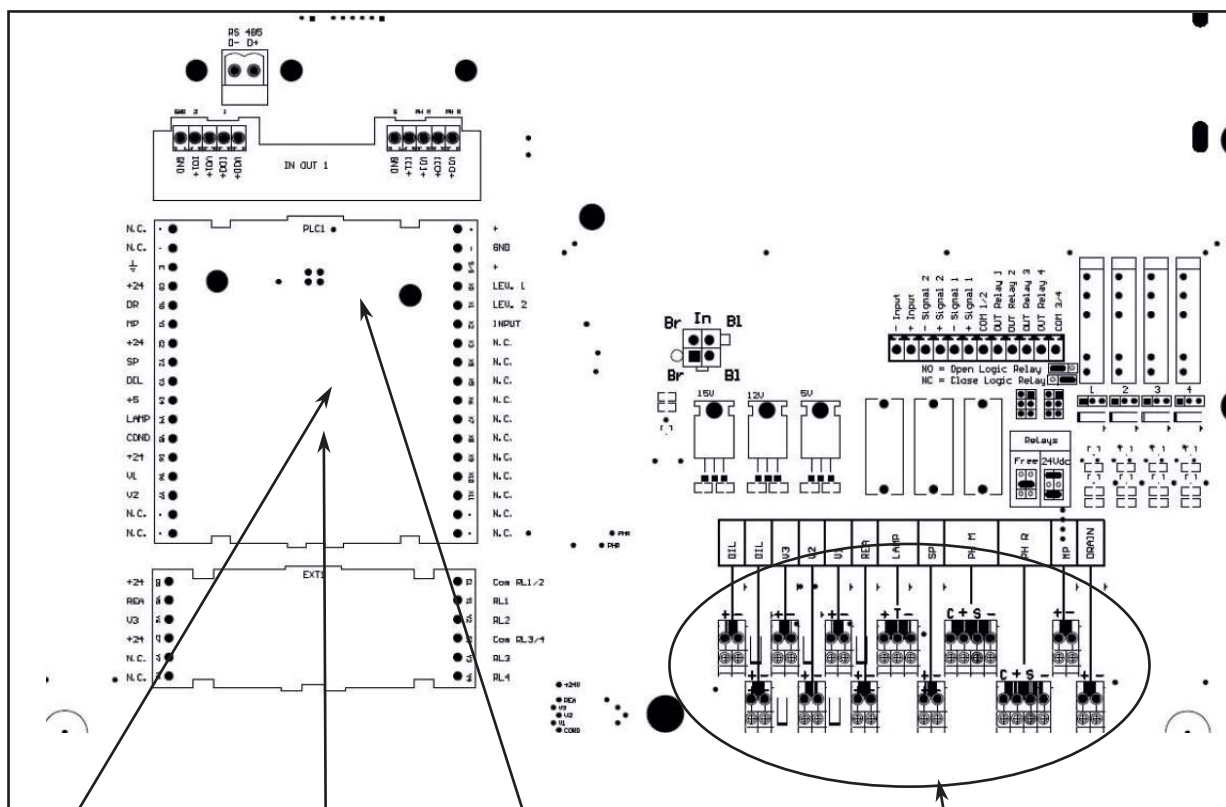

Red LED POW
always lit

green LED meaning RUN
blinking every 2 secs

function LED area, lit when the labeled
component is active

green LED and red LED alternate
and fast blinking showing the
serial communication with the
touchscreen panel

