



# INSTRUCTIONAL MANUAL HYDRA-DS NITRATE ANALYZER



# PREFACE

Purchasing products from Electro-Chemical Devices, Inc. provides you with the finest liquid analytical instrumentation available. If this is your first purchase from ECD, please read the entire manual before installing and commissioning your new equipment.

Manuals are accessible on the ECD website at <https://ecdi.com/product-literature/manuals/>.

If there are any questions concerning this equipment, please contact your local ECD representative, or the factory directly at:

**Electro-Chemical Devices, Inc.**

1500 Kellogg Dr.  
Anaheim, CA 92807 USA





Telephone: +1-714-695-0051

FAX: +1-714-695-0057

Website: [www.ecdi.com](http://www.ecdi.com)

Email: [sales@ecdi.com](mailto:sales@ecdi.com)

## SYMBOLS USED IN MANUAL

	This symbol is used to designate important information, warnings and cautions. Failure to follow this information could lead to harm to the instrument or user.
	No operator serviceable parts, service by authorized service personnel only.
	This symbol is used to designate a WARNING "Risk of Electrical Shock"
	Disconnect supply before servicing
	Equipment protected throughout by double insulation.

Contents of this manual are believed to be correct at the time of printing and are subject to change without notice. ECD is not responsible for damage to the instrument, poor performance of the instrument or losses resulting from such, if the problems are caused by:

- Incorrect operation by the user.
- Use of the instrument in incorrect applications.
- Use of the instrument in an inappropriate environment or incorrect utility program (power supply).
- Repair or modification of the related instrument by anyone not authorized by ECD.
- There are no operator accessible parts. Service and maintenance to be done by authorized personnel only.
- If the equipment is used in a manner not specified by the manufacturer, the protection provided by the equipment may be impaired.

	Read the complete manual before installing or using the equipment.
---	--

© 2019 Electro-Chemical Devices, Inc. All rights reserved. No part of this manual may be used or reproduced in any form or by any means, or stored in a database or retrieval system without prior written permission from Electro-Chemical Devices, Inc. Making copies of any part of this manual for any purpose other than personal use

# TABLE OF CONTENTS

Preface.....	1
Symbols Used in Manual .....	2
Terms and Conditions of Sale .....	6
Return Goods Policy .....	8
Unpacking the Instrument .....	9
1.0 General Description.....	10
1.0.0 Description.....	10
1.0.1 Chloride Ion Compensation .....	10
1.0.2 Optional pH or Ammonium Measurement.....	10
1.0.3 Temperature Compensation.....	10
1.0.4 Cleaning and Maintenance .....	10
1.1 Features .....	11
1.2 HYDRA-DS Sensor Specifications.....	11
1.2.1 Measurement Range .....	11
1.2.2 Operating Temperature .....	11
1.2.3 Min/Max Flow Rate by the sensor.....	11
1.2.4 Wetted Materials.....	11
1.2.5 Accuracy.....	11
1.2.6 Response Time.....	11
1.2.7 Electrode Life .....	11
1.3 Hydra Dimensional Drawing .....	12
1.3.1 Parts List:.....	12
1.4 T80 Transmitter Specifications.....	13
1.6 LQ800 Controller Specifications.....	14
2.0 Installation.....	15
2.1 Unpacking.....	15
2.2 Assembly .....	15
2.2.1 Spray Cleaner .....	15

2.2.2 Immersion/Support Tube .....	15
2.3 Mounting.....	16
2.3.1 HYDRA Sensor Mounting .....	16
2.3.2 T80 Analyzer Mounting.....	16
2.3.3 LQ800 Controller Mounting.....	18
2.4 Wiring.....	19
2.4.1 HYDRA-DS to T80 Transmitter .....	19
2.4.2 HYDRA-DS to LQ800 Controller.....	20
2.4.3 T80 Transmitter Wiring.....	20
2.4.4 LQ800 Wiring .....	24
3.0 Operation .....	27
3.1 T80 Transmitter.....	27
3.2 LQ800 Controller .....	27
3.2.1 Screens.....	27
3.2.2 Menu Structure.....	27
3.2.3 Start Up Guide .....	28
4.0 Calibration .....	29
4.0.1 Recommended Materials.....	29
4.0.2 Temperature Calibration .....	30
4.0.3 Single Point Calibration.....	30
4.0.4 Two Point Calibration .....	31
4.0.5 Chloride Ion Compensation .....	31
4.1 Calibration – T80 Transmitter .....	31
4.1.1 AUTO Calibration Description.....	31
4.1.2 STANDardize Calibration Description .....	32
4.1.3 MANUAL Calibration Description .....	32
4.2 Calibration – LQ800 Transmitter.....	32
4.2.1 AUTO Calibration Description.....	32
4.2.2 STANDardize Calibration Description .....	33

- 4.2.3 MANUAL Calibration Description .....33
- 4.2.4 CAL (Calibration Menu).....33
- 5.0 Maintenance .....34
  - 5.1 Maintenance Schedule.....34
  - 5.2 Cleaning the Sensor .....34
  - 5.3 Replacing the Electrodes.....34
- 6.0 Troubleshooting .....35
- 7.0 Engineering Documentation .....36
  - 7.1 Specifications .....36
    - 7.1.1 Sensor .....36
    - 7.1.2 T80 Transmitter .....36
    - 7.1.3 Model Codes .....38
  - 7.2 Installation .....39
    - 7.2.1 Mounting .....39
    - 7.2 HYDRA-DS Sensor Dimensional Drawing .....40
- 8.0 Ordering Information .....41
  - 8.1 Part Numbers/Model Numbers .....41
  - 8.2 Accessories.....41
  - 8.3 Calibration Solutions .....41
  - 8.4 Spare Parts .....41
- Appendix .....42
  - A. Auto Cal Buffer Tables .....42
  - B. T80 HART Menu .....42
  - C. MODBUS RTU Register Listing .....43

# TERMS AND CONDITIONS OF SALE

1. **ACCEPTANCE.** If this writing differs in any way from the terms and conditions of Buyer's order or if this writing is construed as an acceptance or as a confirmation acting as an acceptance, then Seller's acceptance is **EXPRESSLY MADE CONDITIONAL ON BUYER'S ASSENT TO ANY TERMS AND CONDITIONS CONTAINED HEREIN THAT ARE DIFFERENT FROM OR ADDITIONAL TO THOSE CONTAINED IN BUYER'S WRITING.** Further, this writing shall be deemed notice of objection to such terms and conditions of Buyer. If this writing is construed as the offer, acceptance hereof is **EXPRESSLY LIMITED TO THE TERMS AND CONDITIONS CONTAINED HEREIN.** In any event, Buyer's acceptance of the goods shall manifest Buyer's assent to Seller's terms and conditions. No addition to or modification of these terms will be effective, unless set forth in writing and agreed to by Seller.
2. **WARRANTIES AND REMEDIES**
  - a. **Warranty.** Seller warrants to Buyer that it holds and will pass marketable title to the goods sold hereunder. Seller warrants to Buyer that the items and components manufactured by Seller will be free from defects in material and workmanship (subject, however, to tolerances and variances permitted by the trade hereunder) for a period one (1) year for non-consumable products. Consumable electrodes and sensors have a conditional warranty based shelf life and process conditions and is determined by Seller.
  - b. **Exclusion and Conditions.** Seller's obligations with respect to the express warranties and remedies contained herein are conditioned on the following: (i) Buyer's return of the non-conforming goods, if authorized by Seller; (ii) Buyer shall not assign its rights under these express warranties and any attempted assignment shall render such warranties, but not any disclaimers or limitations, void and the goods sold shall be sold **AS IS**; and (iii) all products shall be carefully inspected for damage by Buyer upon receipt, be properly calibrated for Buyer's particular use, and be used, repaired, and maintained by Buyer in accordance with the instructions set forth in Seller's product literature. Repair and maintenance by non-qualified personnel, product subjected to misuse or negligence, and/or damaged during shipment will invalidate the warranty, as will the use of non-approved consumables or spare parts. As with any other sophisticated product, it is essential, and a condition of Seller's warranty, that all personnel using the product be fully acquainted with its use, capabilities and limitations as set forth in the applicable product literature.
3. **DISCLAIMER OF IMPLIED WARRANTIES.** Seller gives no warranties except those expressly contained herein. Seller **disclaims** all other warranties implied by law usage of the trade, course of dealing or course of performance including, but not limited to, **the implied warranties of MERCHANTABILITY and fitness for a particular purpose.**
4. **LIMITATIONS OF LIABILITY.** The following limitations of Seller's liability are acknowledged by the parties to be fair and reasonable and shall apply to any act or omission hereunder, and to any breach of this contract of which these terms and conditions form a part:
  - a. **Disclaimer of Damage.** In no event shall Seller be liable for special, indirect, consequential or incidental damages whether arising under contract, warranty, tort, strict liability or any other theory of liability. Such damages include but are not limited to loss of profits, loss of use of goods, damage to property, and claims of third parties.
  - b. **Suitability.** Buyer acknowledges that it alone has determined the intended purpose and suitability of the goods sold hereunder. It is expressly agreed by the parties that any technical or other advice given by the Seller with respect to the use of the goods or services is given without charge and at Buyer's risk; therefore Seller assumes no obligation or liability for the advice given or results obtained.
  - c. **Notice and Time of Claims.**
    - i. Buyer agrees to check and inspect all products against shipping papers and for damage or shortage upon receipt of goods at destination.
    - ii. Every claim for shortage, damage in transit, or other cause visible upon inspection shall be deemed waived by the Buyer, or the Buyer's customer in the case of resale, unless delivered in writing to Seller by Buyer thirty (30) days from the tender of delivery of the goods to Buyer, provided, however, that claims for shortage must be made within seven (7) days of receipt.
    - iii. The parties expressly waive the statute of limitations and agree that any legal proceeding for any breach of this contract shall be waived unless filed within one (1) year after the accrual of the cause of action thereof.

5. **FORCE MAJEURE.** Seller shall not be liable for any delay in delivery, or failure to deliver, due to any cause beyond the Seller's control including but not limited to fires, floods, or other forces of the elements; strikes, or other labor disputes; accidents to machinery; acts of sabotage; riots; precedence or priorities granted at the request or for the benefit, directly or indirectly of the federal or any state government or any subdivision or agency thereof; delay in transportation or lack of transportation facilities; restrictions imposed by federal, state or other governmental legislation or rules or regulations thereof. If Seller, in its sole discretion, determines that Seller's performance hereunder would result in a loss to Seller's on this sale as computed under Seller's normal accounting procedures because of causes beyond Seller's control, then the Seller may terminate this agreement in whole or in part without liability for any delay in the delivery of, or failure to deliver, the goods sold hereunder
6. **TAXES AND OTHER CHARGES.** The Buyer will pay, or reimburse Seller if it pays, any and all taxes or tariffs or any other similar charges imposed upon this contract, the goods covered hereby or the delivery or use or resale thereof.
7. **FREIGHT CHARGES.** If the sale hereunder is other than F.O.B. Seller's facility, this acknowledgement is based upon the freight charges now in effect. In the event of an increase or decrease in applicable freight charges before the goods are shipped, such charge in freight will be for the Buyer's account.
8. **PRICES AND DELIVERY.** Prices quoted herein are F.O.B. shipping point. Deliveries specified are only our best estimate and are subject to change. This quotation is based upon freight charges now in effect. Buyer will be invoiced at the freight charge prevailing at the date of shipment. Prices are firm for orders meeting Seller's normal shipping schedules. If shipments are held or postponed for any reason other than Seller's fault, and a price increase becomes effective during the period of such hold or postponement, the increase will apply to all shipments that are held or postponed thirty (30) days or more from the effective date of the increase.
9. **PAYMENTS.** If in the judgment of Seller the financial condition of Buyer at any time prior to shipment does not justify the terms of payment specified, Seller may cancel the order, withhold shipment, and/or require full or partial payment in advance. If payment is not made when due, Seller may suspend all future delivery or other performance with respect to Buyer without liability or penalty and, in addition to all other sums payable hereunder, Buyer shall pay to Seller (i) the reasonable costs and expenses incurred by Seller in connection with all actions taken to enforce collection or to preserve and protect Seller's rights hereunder, whether by legal proceedings or otherwise, including without limitation reasonable attorneys' fees, court costs and other expenses and (ii) interest on all amounts unpaid after 30 days charged at the monthly rate of 1-1/2% or the highest rate permitted by law, whichever is lower.
10. **CANCELLATION OR ALTERATION.** Buyer may not alter or cancel any order without Seller's written consent. For any order altered or cancelled with Seller's consent, Buyer must pay for all expenses and labor incurred up to the time of Seller's consent, plus a reasonable percentage for profit. Any order delayed or deferred by Buyer will be subject to price escalation for increased costs of production, and any other expenses caused by the delay. Material on such orders will be stored at Buyer's risk. Seller reserves the right to invoice Buyer and require payment before shipment of any delayed or deferred order.
11. **TITLE AND RISK OF LOSS.** Title and risk of loss shall pass to buyer at Anaheim, California, unless otherwise specified in the contract. If delivery is made by common carrier, risk of loss shall pass upon delivery to the carrier. Claims for loss or damage in transit must be made by Buyer to the carrier. Seller accepts no responsibility for loss or damage to product in transit.
12. **PATENT OR TRADEMARK INFRINGEMENT.** If the goods sold hereunder are to be prepared for manufacture according to Buyers specification, Buyer shall indemnify Seller against any claim or liability for patent, trademark, service mark or trade name infringement on account of preparation, manufacture and/or sale.
13. **NON-WAIVER.** If Government Contract Regulations require the addition, deletion, or modification of these terms and conditions upon prior notification to Seller and Seller's written acceptance thereof, such changes shall become a part of these terms and conditions. Seller shall not be bound by any Government Contract Regulations applicable to Buyer's contracts with the U.S. Government unless Buyer has expressly acknowledged, on the face of this document, the applicability of such Regulations to the transaction between Buyer and Seller contemplated herein. Absent such acknowledgement, Seller is making the assumption in issuing this document that no such Regulations apply.
14. **JURISDICTION.** All such disputes shall be resolved in a court of competent jurisdiction in Orange County, California. Buyer hereby consents to the jurisdiction of the State and Federal Courts sitting in Orange County. Notwithstanding the above, should either party contest the jurisdiction of such courts, the other party may institute its suit in any court of competent jurisdiction.
15. **APPLICABLE LAW.** All questions arising hereunder or in connection with the quotations or any order submitted in connection therewith and/or the performance of the parties hereunder shall be interpreted and resolved in accordance with the laws of the state of California without regard to its conflict of law provisions and excluding the United Nations Convention on the International Sale of Goods.



# RETURN GOODS POLICY

All requests for returned goods must be initiated through our Customer Service Department. Please call our phone number (714) 695-0051 with the specifics of your request. The following conditions must be satisfied for consideration of applicable credit for the return of products purchased from Electro-Chemical Devices:

- 1) The item is unused and in the original package.
- 2) The item was shipped directly from Electro-Chemical Devices.
- 3) The item has not been damaged in shipment to Electro-Chemical Devices.
- 4) Items containing date-sensitive parts such as electrodes, must be returned within 1 month of the invoiced date.
- 5) Items without date-sensitive parts must be returned within 3 months of the invoiced date.

A Return Merchandize Authorization Number must be obtained from Customer Service and be provided on all paperwork and packaging. To obtain a Return Merchandize Authorization Number, please provide the reason for return, the date of purchase, your original purchase order number, and either our order number or our invoice number. The issuance of a Return Merchandize Authorization Number is a verbal approval for return only and does not guarantee credit or allowance. Returned goods must be received within 30 days of the issuance date of the Return Merchandize Authorization Number or it will become null and void.

Necessary physical and mechanical inspection is completed upon receipt of the item. Applicable credit or equivalent allowance is determined after inspection of the returned item. If all of the above conditions are met, and the item has been approved to return to our stock, a restocking charge of 25% of the purchase price is deducted from the applicable credit.

# UNPACKING THE INSTRUMENT

Your Electro-Chemical Devices instrument has been carefully packaged to protect it from damage during shipment and dry storage. Upon receipt please follow the procedure outlined below.

1. Before unpacking, inspect the condition of the shipping container to verify proper handling by the carrier. If damage is noted, save the shipping container as proof of mishandling for the carrier.
2. Check the contents of the shipping container with the items and quantities shown on the packing list. Immediately report any discrepancies to ECD.
3. Save the original packing material until you are satisfied with the contents. In the event the product(s) must be returned to ECD, the packing material will allow you to properly ship it to ECD.
4. Familiarize yourself with the instrument before installation, and follow proper installation and wiring procedures.



WARNING Electrical installation must be in accordance with the National Electrical Code (ANSI/NFPA-70), Canadian Electrical Code and/or any other applicable national or local codes.

## Installation and Wiring

Failure to follow the proper instructions may cause damage to this instrument and warranty invalidation. Use only qualified personnel to install, operate and maintain the product.

The Model DO82 Sensor should only be used with equipment that meets the relevant IEC, American or Canadian standards. ECD accepts no responsibility for the misuse of this unit.

# 1.0 GENERAL DESCRIPTION

## *1.0.0 DESCRIPTION*

The HYDRA-DS Nitrate Analyzer measures the concentration of dissolved nitrate ion as nitrogen (NO<sub>3</sub>-N) in water. The sensor uses two electrodes to determine the NO<sub>3</sub>-N concentration, a Nitrate Ion Electrode, and a Chloride Ion Electrode. An optional pH or Ammonium electrode is available for additional process information. It is designed for use in all kinds of water. Typical applications include monitoring environmental waters, lakes, streams, and wells as well as wastewater treatment in aeration basins, sludge digesters, and effluent.

## *1.0.1 CHLORIDE ION COMPENSATION*

The Nitrate Ion Electrode provides the primary measurement. Any Chloride ion in the sample, due to its similar size, and charge to the Nitrate ion, causes a positive interference in the measurement. The Chloride Ion Electrode measures the amount of chloride ion present in the sample and HYDRA-DS Analyzer subtracts the appropriate amount of signal from the Nitrate Measurement.

## *1.0.2 OPTIONAL PH OR AMMONIUM MEASUREMENT*

An optional pH or ammonium electrode is available in the HYDRA-DS NO<sub>3</sub> sensor providing additional information about the process solution. The HYDRA-DS Analyzer provides an additional 4-20 mA output to transmit this information.

## *1.0.3 TEMPERATURE COMPENSATION*

Temperature is also measured and used to compensate each of the three electrode measurements. While the pH electrode response is well defined with respect to temperature, the ion electrode tends to be less well behaved. For the best results calibrate the sensors near the process temperature.

## *1.0.4 CLEANING AND MAINTENANCE*

The HYDRA-DS Nitrate Analyzer is configured to periodically actuate a cleaning cycle using the integral spray cleaner in the sensor. The period and duration of the cleaning cycle is user configurable. The 4-20 mA output is held at either the last value or a preset value during the cleaning. This minimizes the formation biofilms or other coatings on the electrodes keeping maintenance to a minimum.

The rugged HYDRA-DS sensor has a 1 ¼" NPT rear facing thread for attaching an extension/immersion tube for easy installation from catwalks or handrails. The HYDRA-DS sensor is submersible with an IP68 degree of ingress protection. A removable electrode guard facilitates easy electrode replacement when necessary. The HYDRA-DS sensor features internal signal conditioning that allows the sensor to be mounted up to 200 meters from the analyzer.

## 1.1 FEATURES

- Separate, economical, easily replaceable Nitrate, Chloride, and optional pH electrodes
- Fast and Accurate Nitrate Measurement  $\text{NO}_3$  or  $\text{NO}_3\text{-N}$
- Automatic compensation for Cl interference
- Temperature compensated  $\text{NO}_3\text{-N}$  measurement
- Rugged PVC design with removable electrode guard for easy maintenance
- Integral Spray Head Cleaner
  - Cleans sensor in situ with turbulence caused by pressurized air
- Internal Signal Conditioning allows up to 200 meters between Sensor and Analyzer

## 1.2 HYDRA-DS SENSOR SPECIFICATIONS

- Three Electrode System with spray cleaner
- Nitrate ISE ( $\text{NO}_3\text{-N}$ ) is the primary measurement
- Chloride ISE is used for compensation of the  $\text{NO}_3$  signal
- Optional pH or  $\text{NH}_4^+$  electrode
- The Sensor is waterproof with an ingress rating of IP68

### 1.2.1 MEASUREMENT RANGE

- $\text{NO}_3\text{-N}$  0.1 to 1000 ppm
- Cl 0.1 to 10,000 ppm
- pH 2-12 ph
- $\text{NH}_4^+$  0.1 to 1000 ppm

### 1.2.2 OPERATING TEMPERATURE

- 0 °C to 40 °C (32 °F to 104 °F)

### 1.2.3 MIN/MAX FLOW RATE BY THE SENSOR

- Minimum 0.1 m/s
- Maximum 3.0 m/s

### 1.2.4 WETTED MATERIALS

- PVC, PEC, PVDF, PTFE, Viton, Glass, 316 SS

### 1.2.5 ACCURACY

- $\pm 3\%$  of reading, dependent on Calibration

### 1.2.6 RESPONSE TIME

- T90 approximately 1 minute

### 1.2.7 ELECTRODE LIFE

- ISEs: 4-6 months, typical
- pH electrode: 6-12 months, typical

## 1.3 HYDRA DIMENSIONAL DRAWING

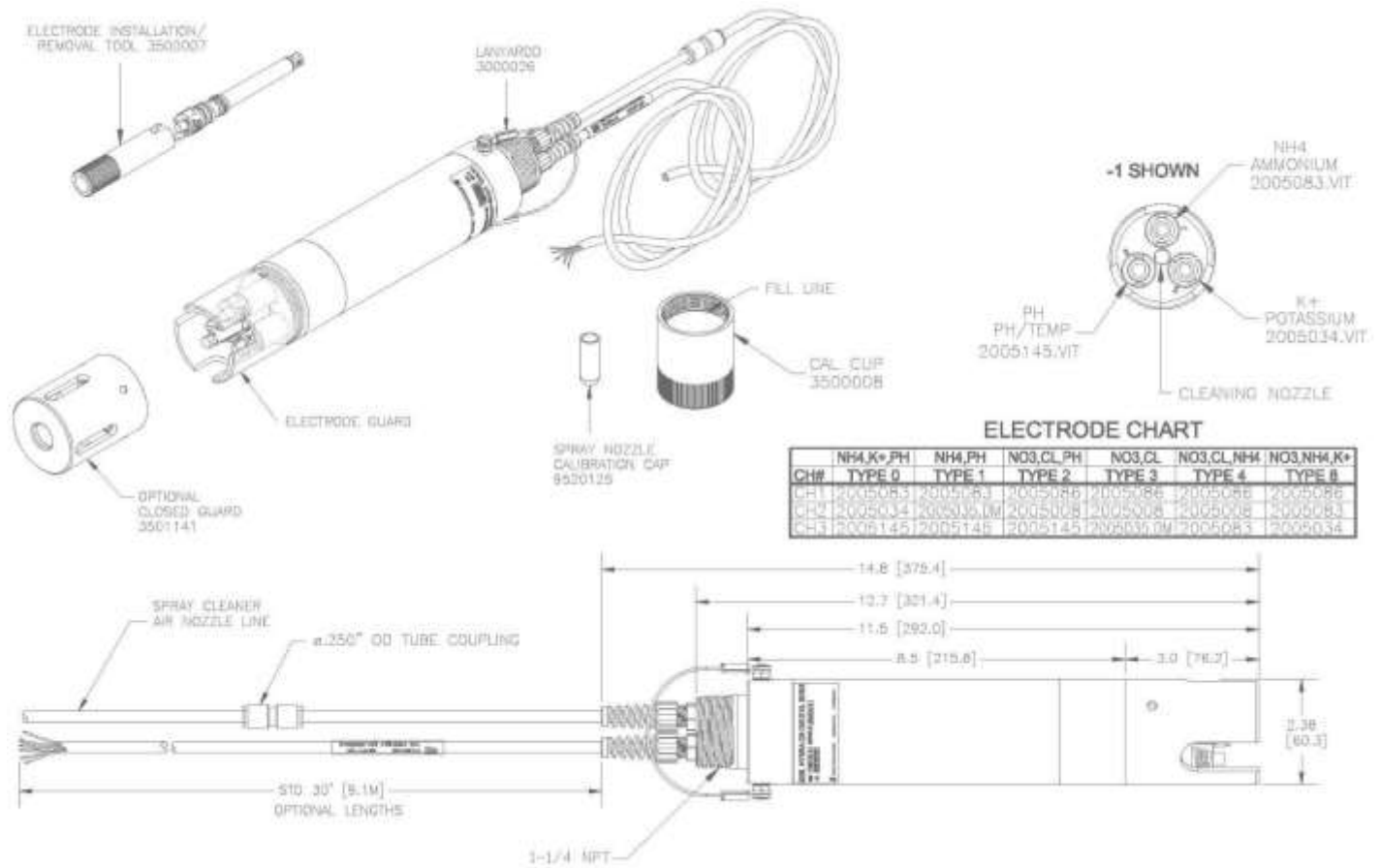

### 1.3.1 PARTS LIST:

- HYDRA-DS Sensor with Electrodes, Calibration Cap
- 30' of 1/4" air tubing, Electrode Removal Tool

## 1.4 T80 TRANSMITTER SPECIFICATIONS

The ECD Model T80 transmitter is an intelligent single or dual channel multi-parameter transmitter designed for the online continuous measurement of pH, ORP, pION, conductivity, resistivity, or Dissolved Oxygen in a general purpose industrial environment. The Model T80 transmitter digitally communicates with any ECD S80 digital sensor. The measurement identity is contained in the sensor's memory. Then an S80 sensor is connected to the transmitter it automatically configures the transmitter's menus and display screens to the measured parameter.

The Model T80 transmitter can be loop powered, 24 VDC powered, or 100-240 VAC line powered. The standard configuration has a 4-20 mA output and an RS485 serial communication port with MODBUS® RTU output. A HART® communication version (single channel version only) is also available. Alarm relays are optionally available on either line powered transmitter.

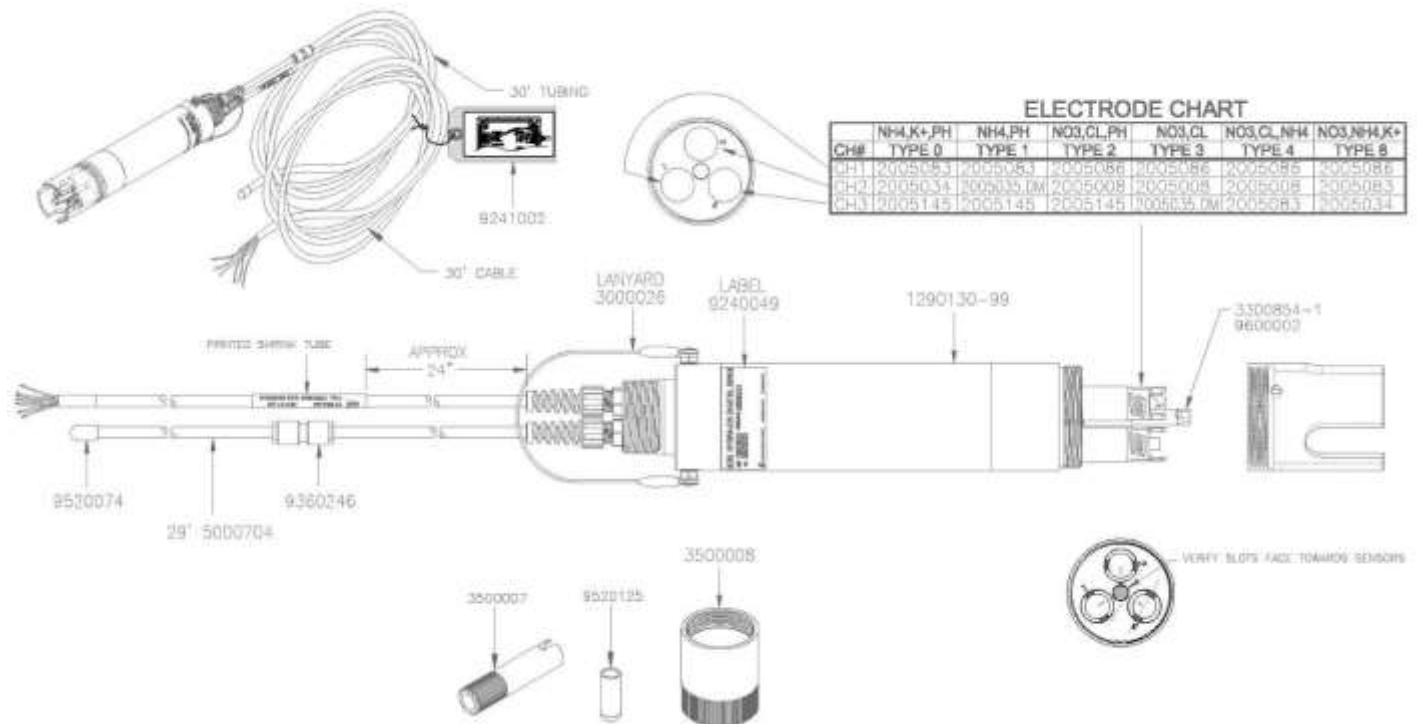

### Features:

- Multi-Parameter, pH, ORP, Specific Ion, Dissolved Oxygen, Conductivity, Resistivity
- Simple, user friendly menu structure
- Noise free digital communication with sensor
- Reads and writes calibration data to sensor
- Dual Channel option has interactive channels, pH compensated reading, and interfering ion corrections
- Non-isolated 4-20 mA output and MODBUS® RTU standard, optional HART®

## 1.6 LQ800 CONTROLLER SPECIFICATIONS

The ECD LQ800 transmitter is a one to eight channel, intelligent, multi-parameter transmitter designed for the online continuous measurement of pH, ORP, pION, dissolved oxygen, conductivity, resistivity, turbidity, flow, level, and many others in carrying configurations for a given application. The Model LQ800 Controller digitally communicates with any ECD DS80 digital sensor, automatically configuring the transmitter's menus and display screens to the measured parameter.

The Model LQ800 Controller can be 24 VDC powered or 100-240 VAC line powered. Available options include, (8) 4 to 20 mA outputs, (8) configurable Relays (for Alarm, activated timers, control, and Fault), and Ethernet communication.

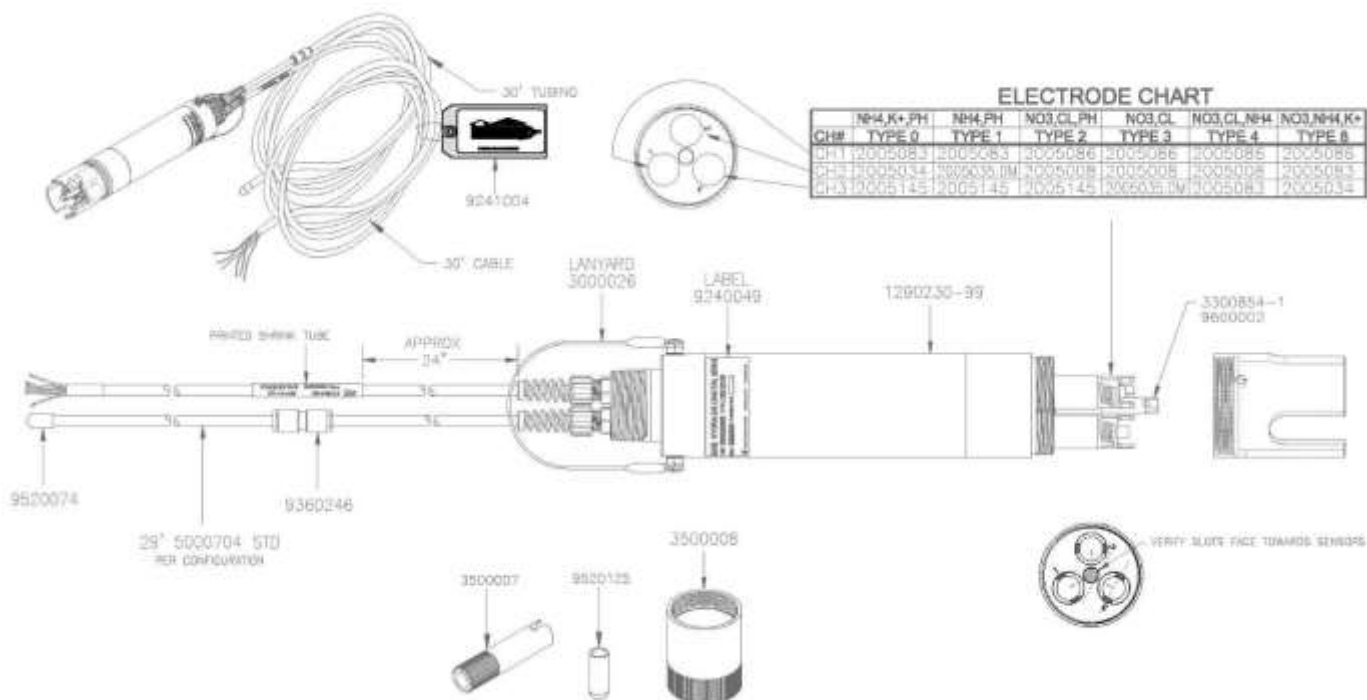

### Features:

- Multi-Parameter, pH, ORP, Specific Ion, Dissolved Oxygen, Conductivity, Resistivity, Turbidity, Flow, and Level
- Simple, user friendly menu structure
- Noise free digital communication with sensors
- Reads and writes calibration data to sensor
- Multi-channel option has interactive channels, pH compensated readings, interfering ion corrections
- Non-Isolated 4-20 mA output and Ethernet

## 2.0 INSTALLATION

### 2.1 UNPACKING

Carefully remove the HYDRA-DS sensor from its shipping container. Inspect the sensor for damage. Verify the electrodes, Ammonium, Potassium, and pH and the Spray Cleaner Nozzle are installed in the sensor housing. The electrodes should be hand tightened into place so that the sealing o-rings are not visible. The electrodes are supplied with protective caps that must be removed before start up. Do not remove the caps until ready to use.

**\*\*\*Never support the HYDRA-DS Sensor by the cable, irreparable damage will occur\*\*\***

### 2.2 ASSEMBLY

The Hydra-DS Sensor is shipped completely assembled. Before use, it must be connected to the analyzer and an air supply. Connect the spray cleaner feed tube to a compressed air supply controlled by a solenoid valve (not supplied). Attach an immersion/support tube (not supplied). Finally connect the sensor wires and 110 VAC power to the analyzer as shown on the wiring diagram. Connect the Cleaner Relay to the solenoid, and connect the 4-20 mA Output(s) and Alarm Relays to the Control System (PLC or DCS). The HYDRA-DS is then ready to use.

#### 2.2.1 SPRAY CLEANER

The Spray Cleaner uses compressed air to create turbulence around the electrodes which removes dirt and films from the measurement surfaces. Depending on the process being measured the cleaner should be actuated for 15-30 seconds every 0.25-2 hour period. The spray cleaner connection is a ¼" compression fitting and requires between 35-75 psi air pressure. The air supply is controlled with a user supplied solenoid valve through Relay 1 in the T80 analyzer. The solenoid valve should be a 110 AC powered, < 10 watt devices. Wire the solenoid to Relay 1 as described in Section 2.4.4 below.

If no air supply is available use the ECD Model AC10 Air Blast Spray Cleaner compressor. The AC10 uses redundant intake air filters and redundant fuses on both the relays and the compressor. A highly reliable high current contactor assures years of trouble free service. The 115 VAC 3.0 Amp or 220 VAC 1.3 Amp Air Compressor is housed in a rugged, corrosion resistant, hot compression molded, fiberglass reinforced polyester enclosure with a stainless steel piano hinge to secure the cover to the base. The AC10 can be wall mounted or use the optional 2" handrail mounting system that uses stainless steel support rails with two 2" galvanized pipe clamps.

**\*\*\*Never support the HYDRA-DS Sensor by the cable, irreparable damage will occur\*\*\***

#### 2.2.2 IMMERSION/SUPPORT TUBE

Feed the cable and compressed air line through the immersion/support tube (not supplied). Connect a support tube to the 1 ¼" MNPT thread at the rear of the sensor. The HYDRA-DS Sensor weighs approximately 5.3 lbs. The support tube must be able to support the weight of the HYDRA-DS Sensor in the user's installation, whether vertical or angled. The recommended material for the immersion tube is 1.5" Schedule 80 PVC pipe with a reducer fitting to 1 ¼" FNPT.



## 2.3 MOUNTING

### 2.3.1 HYDRA SENSOR MOUNTING

Install the sensor where the measured sample is representative of the entire process. Although the sensor will function in a quiescent sample, flow improves the measurement. The recommended minimum flow is 0.1 m/sec.

Securely mount the HYDRA-DS sensor with the measuring end at least 6" away from the tank wall and bottom. Ensure that the sensor is immersed at least 6" at all times.

Use care when servicing the sensor to ensure that the sensor does not hit the tank wall or bottom, which could break the sensing electrodes.

### 2.3.2 T80 ANALYZER MOUNTING

Mount the T80 in a location where there is easy access to the analyzer and sensor. Install the system in an area where vibrations, electromagnetic, and radio frequency interference are minimized or absent. So not mount in direct sunlight or areas of extreme heat (temperature > 120°F). The IP65 T80 is suitable for outdoor use but it is best to mount it with a protective cover or sunshield to prevent discoloring over the years.

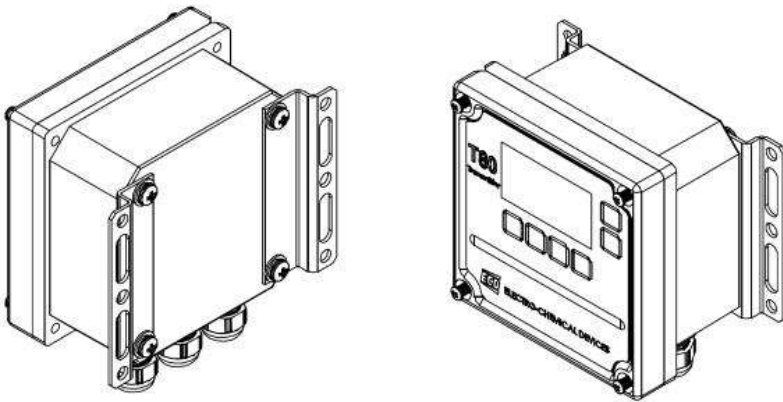

Universal Mounting Brackets

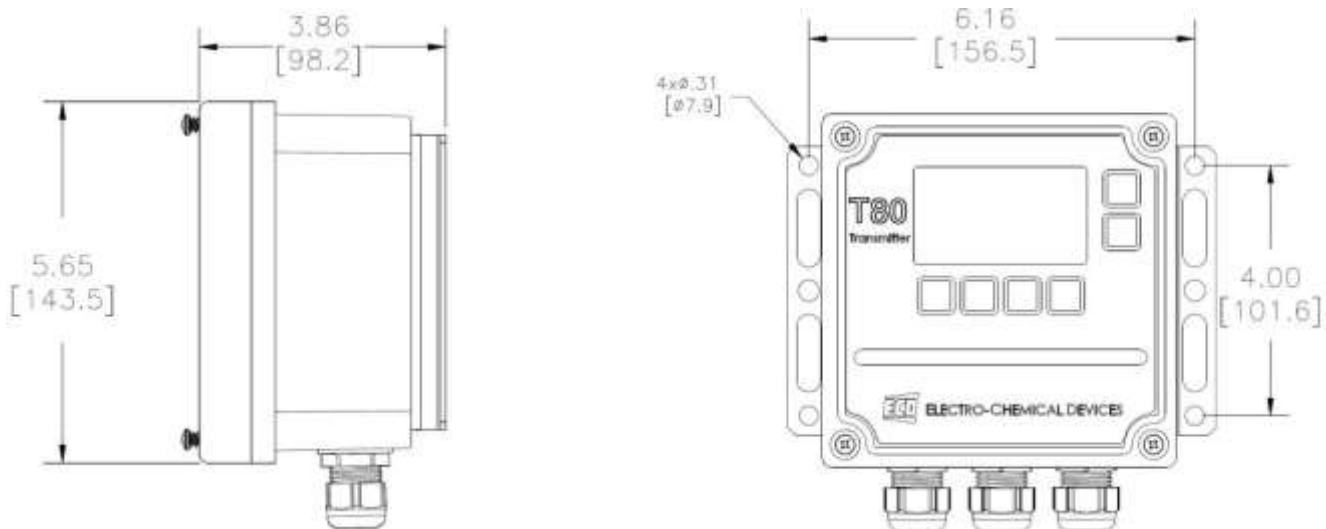

Rail Mounting

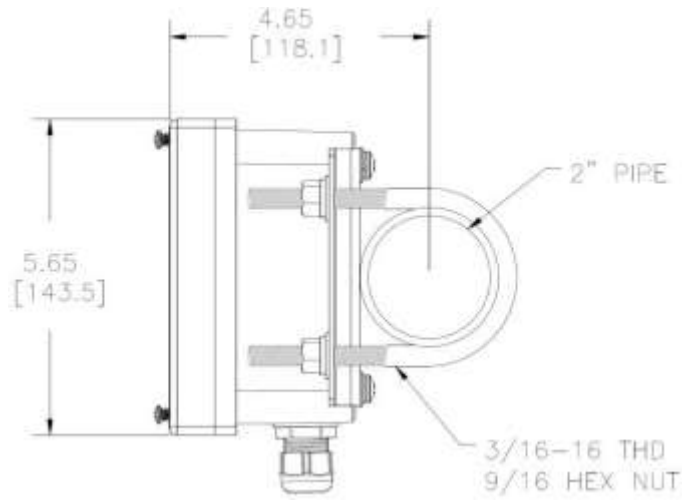
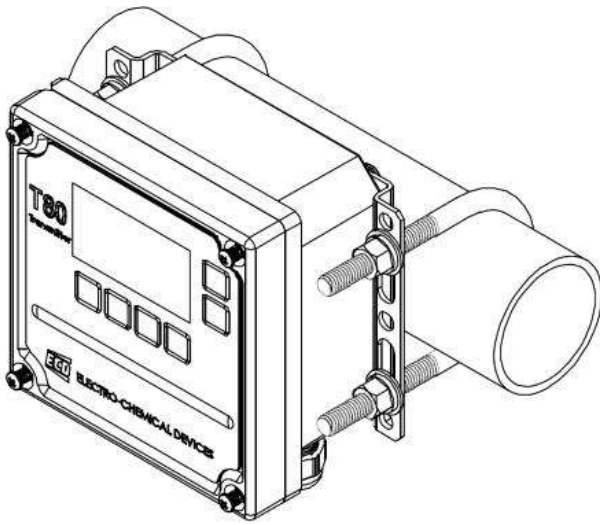

Panel Mounting

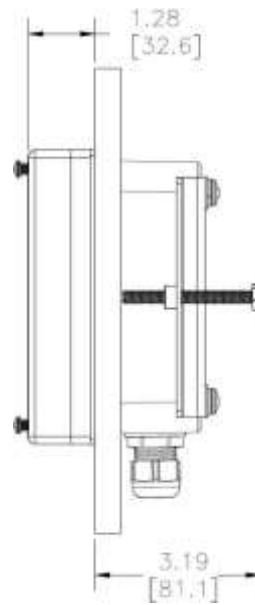
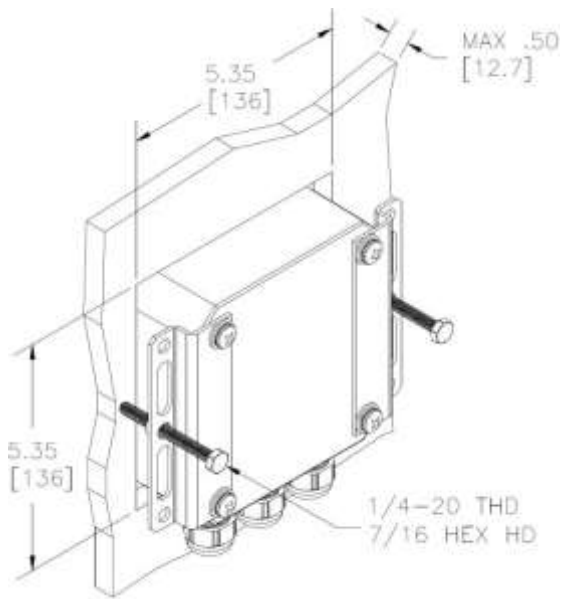

Cut Out: 5.35" x (13.6cm x 13.6cm)

### 2.3.3 LQ800 CONTROLLER MOUNTING

Mount the LQ800 in a location where there is easy access to the analyzer and sensors. Install the system in an area where vibrations, electromagnetic, and radio frequency interference are minimized or absent. Do not mount in direct sunlight or areas of extreme heat (temperature > 120°F). The IP65 LQ800 is suitable for outdoor use but it is best to mount it with a protective cover or sunshield to prevent discoloring over the years.

#### Universal Mounting Brackets

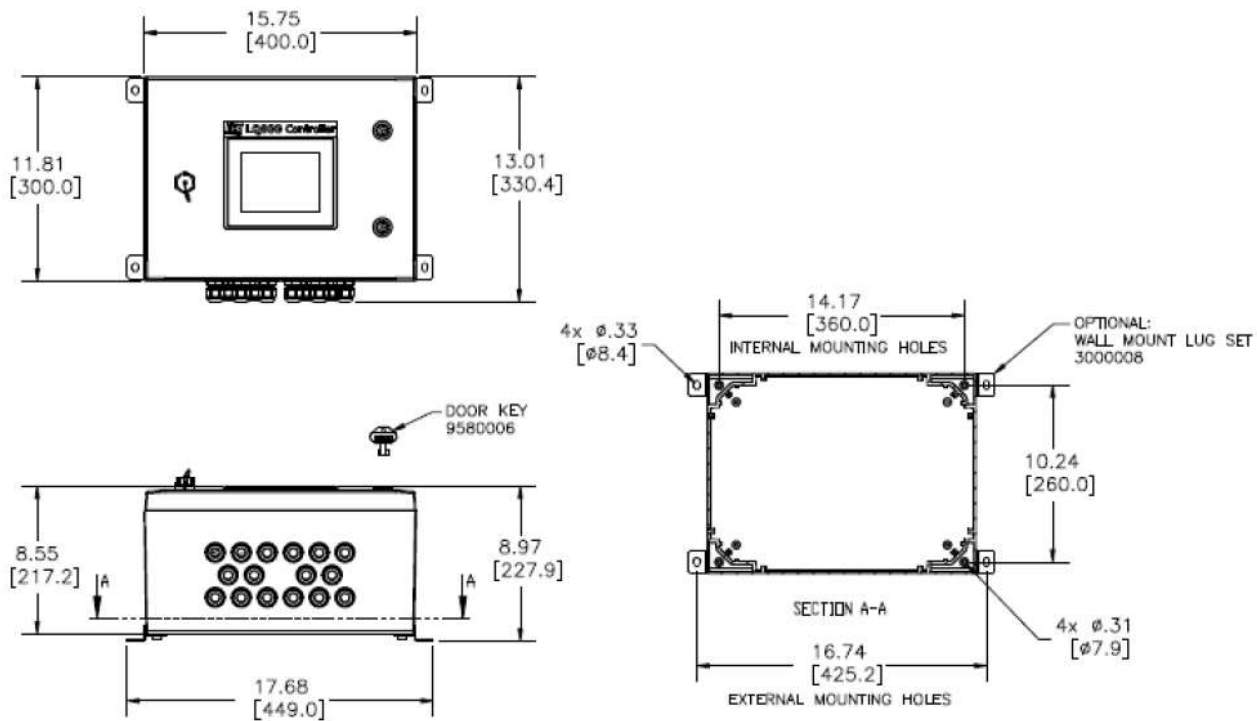

## 2.4 WIRING

### 2.4.1 HYDRA-DS TO T80 TRANSMITTER

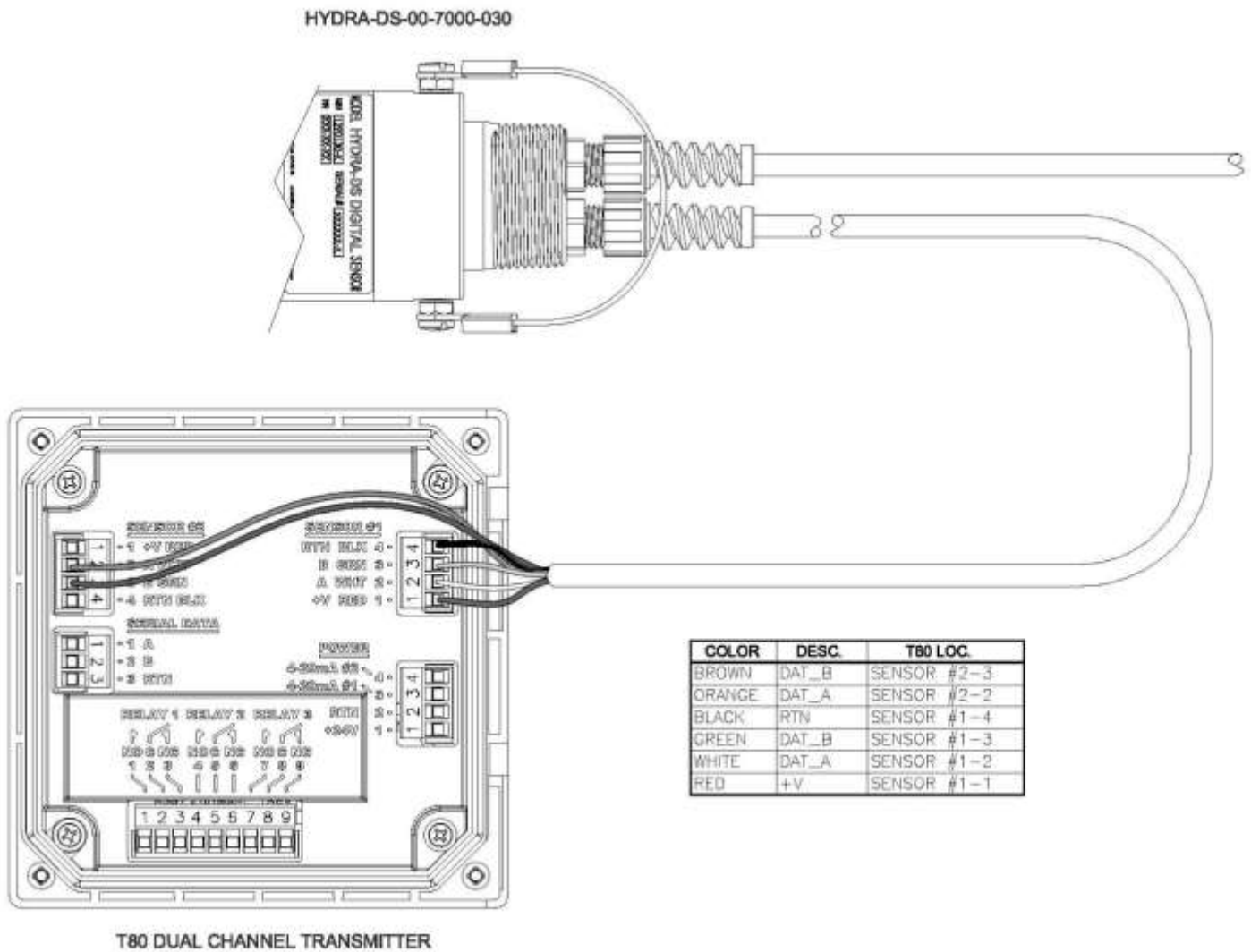

## 2.4.2 HYDRA-DS TO LQ800 CONTROLLER

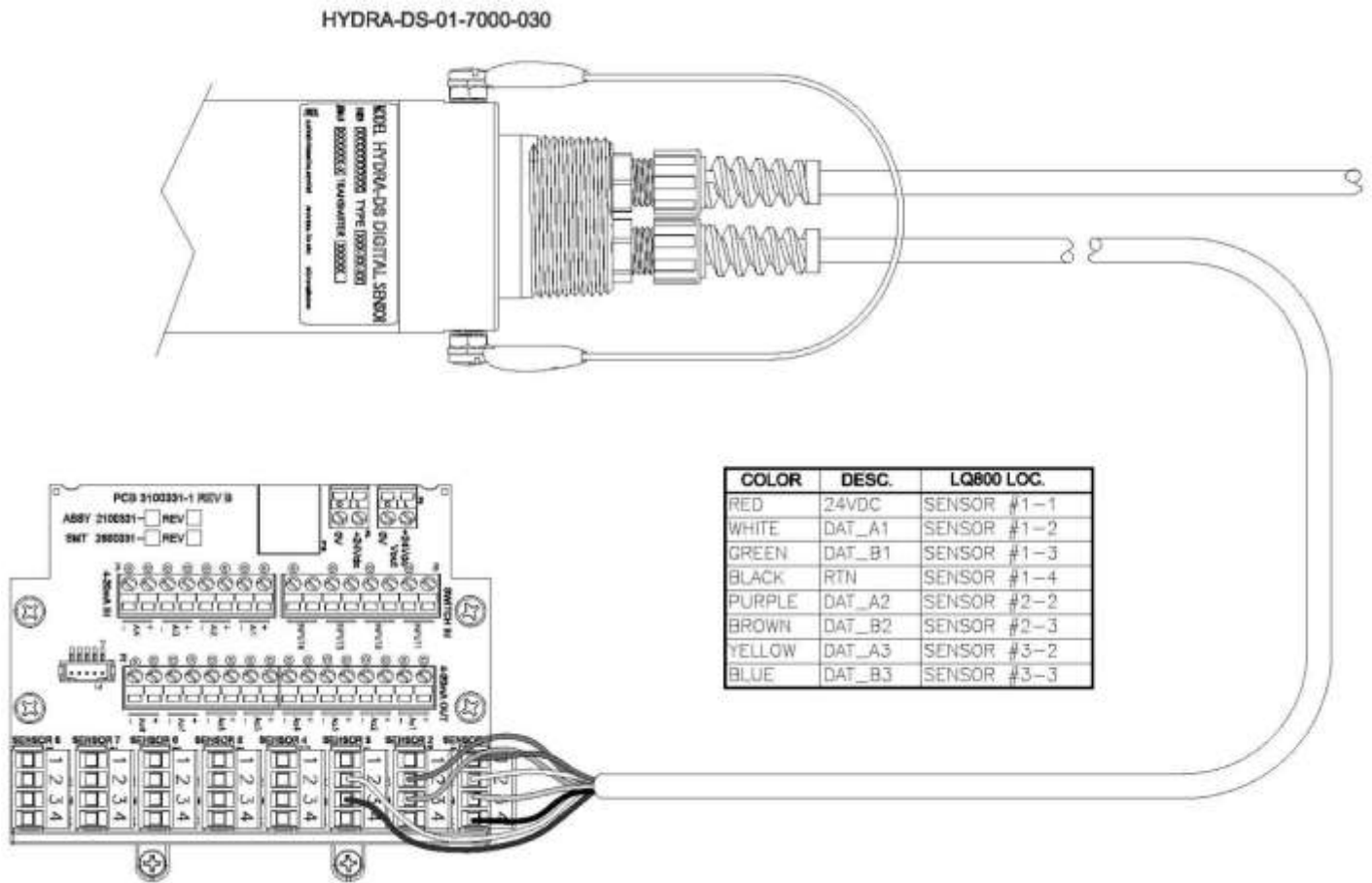

## 2.4.3 T80 TRANSMITTER WIRING

Electrical wiring should only be conducted by qualified personnel. See the following T80 wiring diagrams.

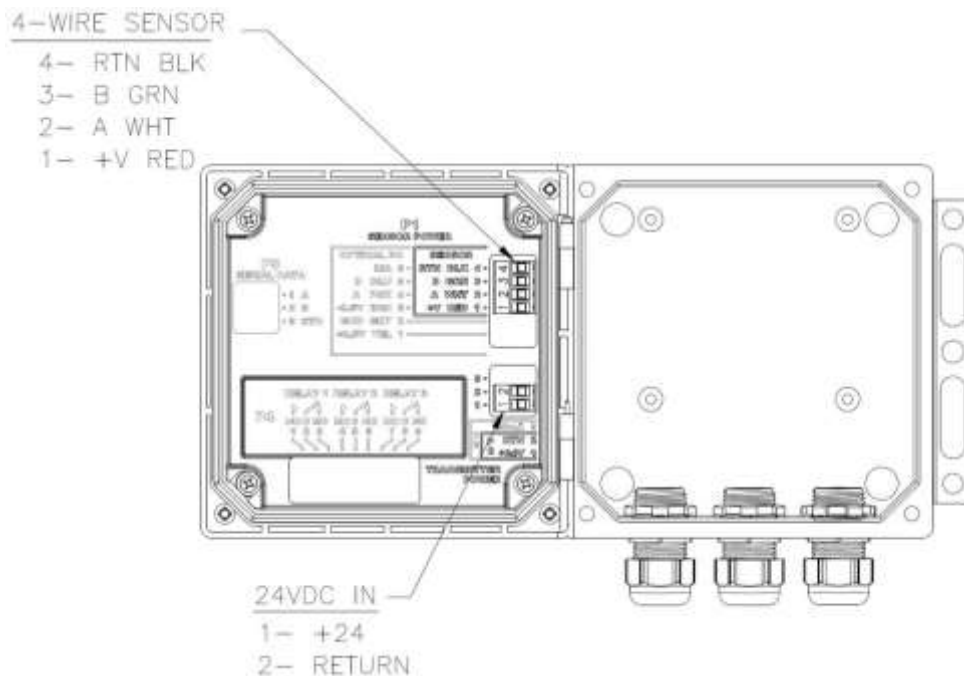

Figure 2.4.3.1 - Loop Powered Transmitter

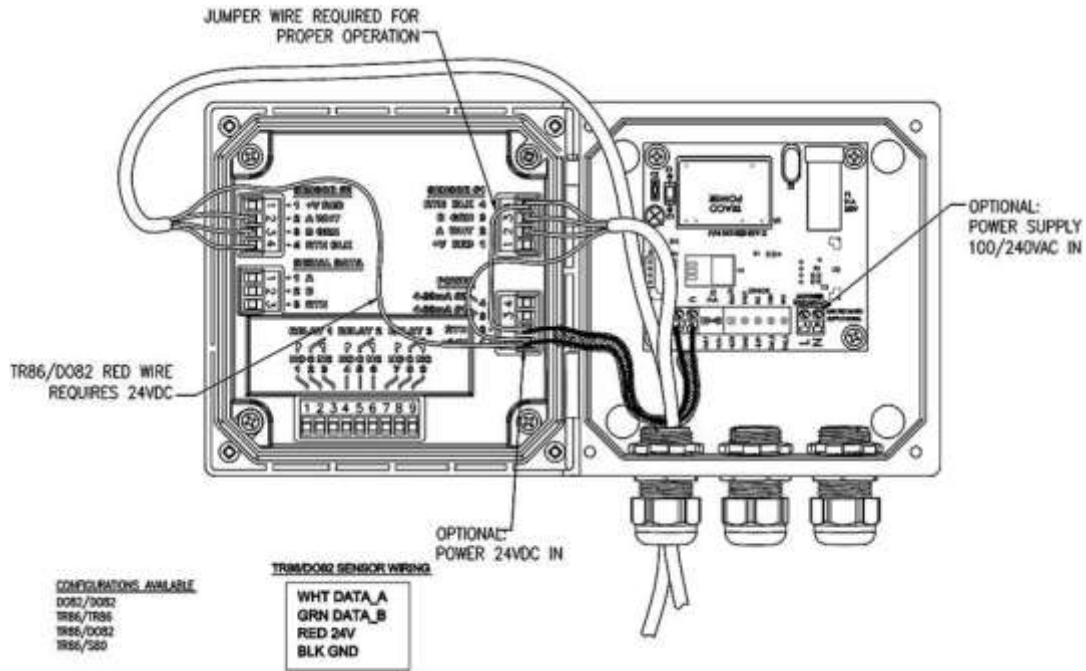

Figure 2.4.3.2 - 4-Wire Transmitter, Model TR86 turbidity and Model DO82 Dissolved Oxygen sensors

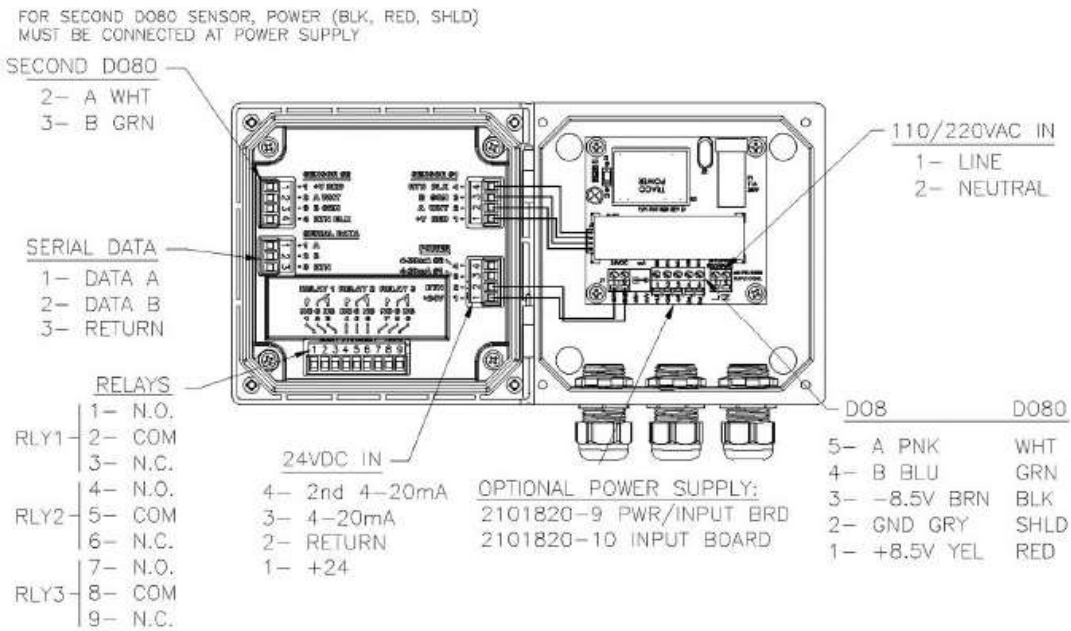
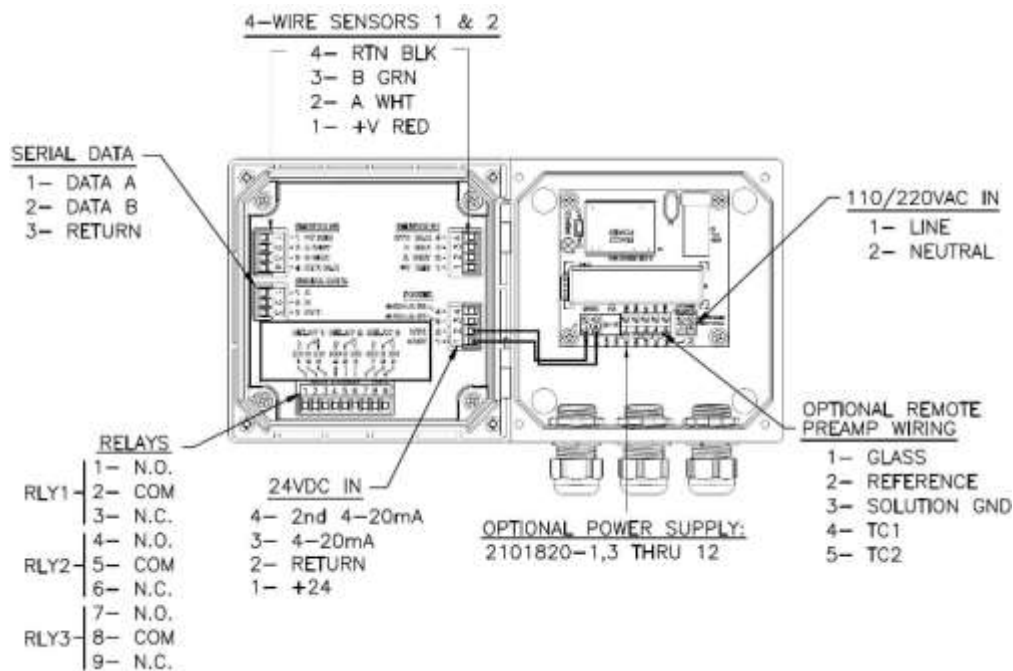

Figure 2.4.3.3 - 4-Wire Transmitter, 24VDC or /110/220 VAC, MODBUS, Relays/Optional Digital Preamp



Warning: RISK OF ELECTRICAL SHOCK



Disconnect Power before opening instrument



WARNING Electrical installation must be in accordance with the National Electrical Code (ANSI/NFPA-70) Canadian Electrical Code and/or any other applicable national or local codes.

#### 2.4.3.1 WIRING, POWER

ECD recommends using a thermoplastic, outdoor sunlight resistant jacketed cable, we location rated and ½” flexible conduit. The power should be hard wired with a switch or breaker to disconnect the analyzer from the main power supply. Install the switch or breaker near the analyzer and label it as the Power Switch for the analyzer.

##### LOOP POWERED (2 wire configuration)

Attach the 24VDC signal cable to terminals #1 and #2 as shown in Figure 2.4.3.1 and on the diagram inside of the T80 cover. Feed the cable through the gland fitting on the right hand side of the T80. Tighten the cable gland to provide a good seal to the cable. The instrument can be powered up at this point, with no harm to the analyzer, but it is best to wait until the sensor is installed.

##### 24VDC (4 wire configuration)

Attach the 24VDC power cable to terminals #1 and #2 as shown in Figure 2.4.3.2 and on the diagram inside of the T80 cover. Attach the 4-20 mA1 cable to terminals #3 (out) and #2 (return) single channel unit and attach the 4-20 mA2 cable to terminals #4 (out) and #2 (return) for a two channel instrument. Feed the cable. The instrument can be powered up at this point with no harm to the analyzer but it is best to wait until the sensor is installed.

### 110/220 VAC (4 WIRE CONFIGURATION)

Attach power cable as shown in Figure 2.4.3.2 or as on the diagram inside the T80 cover. Feed the sensor cable through the gland fitting on the left hand side of the T80. Do not use the same gland fitting for the AC power or the Alarm/Relays. The green terminal strip connectors are detachable from the circuit boards. Remove the connector by pulling straight back from the circuit board.

### 2.4.3.2 WIRING, 4-20 MA OUTPUTS

#### LOOP POWERED INSTRUMENTS:

Connect the 4-20mA cable to terminals #1 (+24V) and #2 (-24V), Model T80-XX-0 X-XX.

#### 24 VDC OR 110/220 VAC POWERED INSTRUMENTS:

For instruments powered with 24VDC or the internal power supply, Model T80-XX-1X-XX (24VDC) and T80-XX-2X-XX (110/220 VAC), connect the 4-20 mA cable(s) to terminals #3 (out) for channel 1 and #2 (return) and to terminals #4 (out) for channel 2 and #2 (return).

Transmitters with the HART® Communication can be wired as shown in Section 2.4.3. See HART® Communication menu in Appendix B.

### 2.4.3.3 WIRING, CONTACT RELAY OUTPUTS

The standard configuration has three SPDT 230V 5 A relays that can be wired either **normally open (NO)** or **normally closed (NC)**. The default is set to use the relays as normally open.

### 2.4.3.4 WIRING, SERIAL OUTPUT MODBUS RTU

Attach the sensor wires as shown in Figure 2.4.3.2 or as described on the diagram inside the the T80 cover. Feed the sensor cable through the gland fitting on the left hand side of the T80. Do not use the same gland fitting for the AC power or Alarm/Relays. See MODBUS command register in Appendix C.

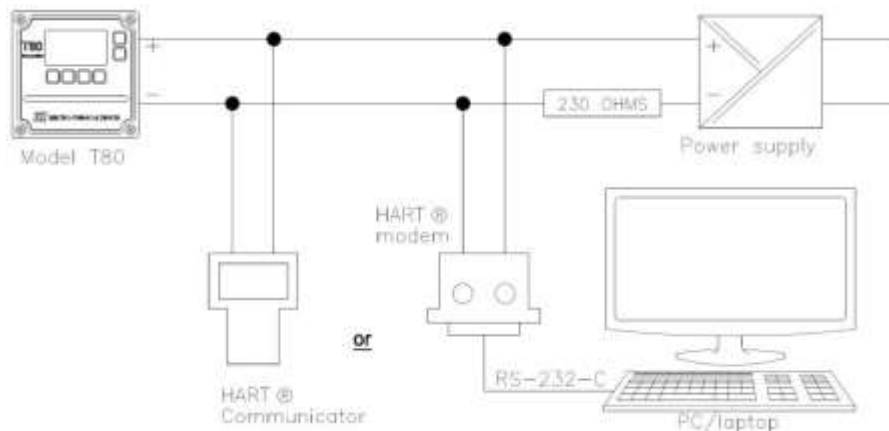



### 2.4.4 LQ800 WIRING

Electrical wiring should only be conducted by qualified personnel.

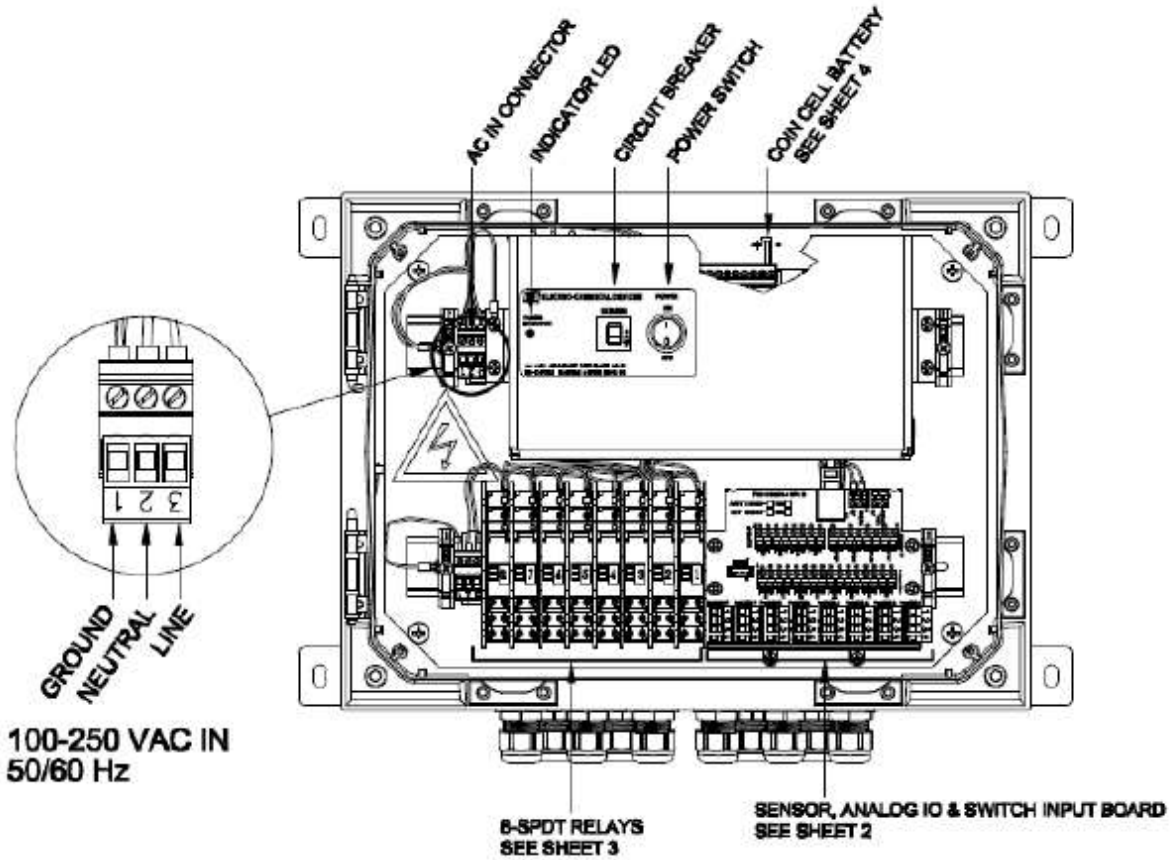

Figure 2.4.4.1 - 110-250 VAC wiring diagram

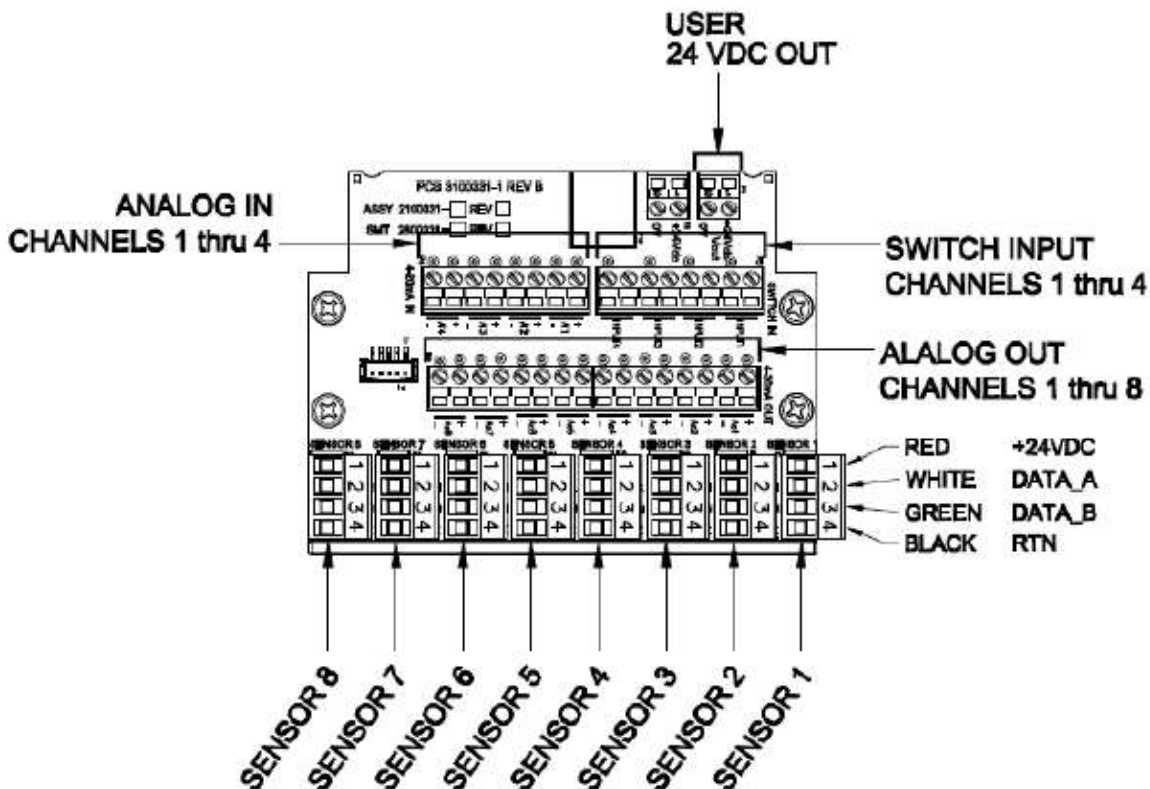

Figure 2.4.4.2 - 4-Wire Transmitter, 24VDC or /110/22 VAC, Sensor 1-8, Analog Output, Switch Input, Analog Input

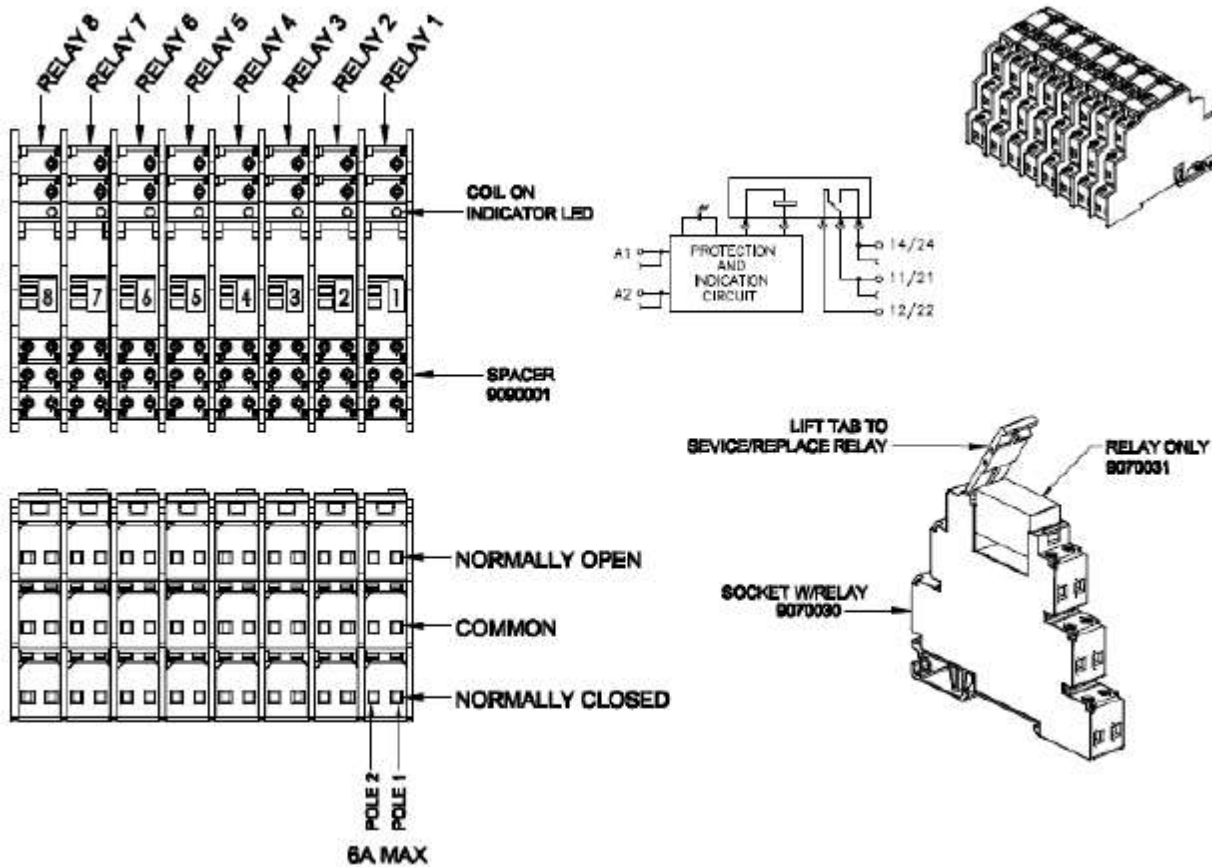





Figure 2.4.4.3 - Relay Configuration

	<p>WARNING: Risk of Electrical Shock</p>
	<p>Disconnect Power before opening instrument</p>
	<p>WARNING: Electrical installation must be in accordance with the National Electrical Code (ANSI/NFPA-70), Canadian Electrical Code, and/or any other applicable national or local codes.</p>

#### **2.4.4.1 WIRING, POWER**

ECD recommends using a thermoplastic, outdoor sunlight resistant jacketed cable, wet location rated and ½" flexible conduit. The power should be hard wired with a switch or breaker to disconnect the analyzer from the main power supply. Install the switch or breaker near the analyzer and label it as the Power Switch for the analyzer.

#### **110/220 VAC (4 wire configuration):**

Attach power cable as shown in Figure 2.4.4.1. Feed the cable through the gland fitting on the left hand side of the LQ800. Tighten the cable gland to provide a good seal to the cable. The instrument can be powered up at this point with no harm to the analyzer, but it is best to wait until the sensor is installed.

#### **2.4.4.2 WIRING, SENSOR**

Attach the sensor wires as described on Figure 2.4.4.1. Feed the sensor cable through the gland fitting on the left hand side of the LQ800. Starting with Sensor 1 is located on the far bottom right side of the circuit board and will go in numerical succession with sensor 8 on the far bottom left. The green terminal strip connectors are detachable from the circuit boards. Remove the connector by pulling straight back from the circuit board.

#### **2.4.4.3 WIRING, 4-20 MA OUTPUTS**

#### **110/220 VAC powered instruments:**

The analog Output is shown in Figure 2.4.4.2. It is located above the Sensor connections on the circuit board. The analog output are labeled as **Ao1** to **Ao8**. Ao standing for analog out, Ao1 will be located on the right side of the circuit board and will go in numerical succession with sensor 8 on the left side.

#### **2.4.4.4 WIRING CONTACT RELAY OUTPUTS**

The standard configuration has 8 SPST 230V 6A relays that can be wired either normally open (NO) or normally closed (NC). Diagram of the relays can be shown in Figure 2.4.4.3.

#### **2.4.4.5 WIRING, ANALOG INPUT**

The analog Input is shown in Figure 2.4.4.2. It is located above the analog output connections on the circuit board. The analog inputs are labeled as Ai1 to Ai8. Ai standing for analog in, Ai1 will be located on the right side of the circuit board and will go in numerical succession with Ai8 on the left side.

#### **2.4.4.6 WIRING, DIGITAL INPUT**

The Digital Input is shown in Figure 2.4.4.2. It is located above the analog output connections on the circuit board. The digital inputs are labeled as Di1 to Di8. Di standing for digital in, Di1 will be located on the right side of the circuit board and will go in numerical succession with Di8 on the left side.

## 3.0 OPERATION

### 3.1 T80 TRANSMITTER

The ECD Model T80 transmitter is an intelligent, single or dual channel multi-parameter transmitter designed for the online continuous measurement of pH, ORP, pION, conductivity, resistivity or Dissolved Oxygen in a general purpose industrial environment. The Model T80 transmitter digitally communicates with any ECD S80 digital sensor. The measurement identity is contained in the sensor's memory. When an S80 sensor is connected to the transmitter, it automatically configures the transmitter's menus and display screens to the measured parameter.



The functions associated with each key are displayed on the screen, above the key for the Selection Adjustment Keys and to the left of the key for the HOME and BACK keys. **Press any Selection Adjustment key twice within one second to enter the HOME Menu Screen.**

### 3.2 LQ800 CONTROLLER

The ECD Model LQ800 transmitter is an intelligent, single to eight channel multi-parameter controller designed for the online continuous measurement of pH, ORP, pION, conductivity, Resistivity, Dissolved Oxygen, Flow, and Level in a general purpose industrial environment.

The model LQ800 controller digitally communicates with any ECD DS80 digital sensor. The measurement identity is contained in the sensor's memory. When a DS80 sensor is connected to the controller, it automatically configures the controllers, menus, and display screens to the measured parameter.



#### 3.2.1 SCREENS

The LQ800 has a touch screen interface that is easy to use. To access Sensor menu screen, tap or press on the Channel Box of the sensor you would like to access. To access the LQ800 Controller menus and functions, tap or press on the MENU on the screen.

The **Home Screen** displays the Controllers Menu button, channels, measurement type, numerical value, the engineering units, alarms, date and time.

#### 3.2.2 MENU STRUCTURE

Pressing the **Menu** button on the home screen will prompt you to the **Menu Home** Screen. You will be able to set the analyzer on Hold, and access the **Alarm logs**, **CONFIGuration** settings, and Info Screens.

##### 3.2.2.1 HOLD (OUTPUT HOLD)

Pressing the **Menu** button on the screen will prompt you.

- Freezes the 4-20 mA output at the last value prior to activation
- Freezes optional Alarm Relays in the current state
- Will let you set up the Timeout of the hold system which is configurable with the number entry screen

Pressing HOLD again turns the hold function off, Hold is OFF, displayed. The HOLD function remains ON until it is turned OFF.

### 3.2.2.2 ALARM LOG

Pressing the Alarm log button will give you the screen which will inform you of the triggered alarms. It will state the occurrence of the alarm, the message associated with the occurrence.

Fault	Definition	Recommendation

### 3.2.2.3 CONFIG (CONFIGURATION MENU)

Three options are available in the Configure Menu, Display, Ethernet Settings, and Re-Scan Sensors.

- Configure Display
  - Screen Save ON/OFF
  - Timeout (20 min)
    - Configurable using number entry screen
  - Beep ON/OFF
  - Brightness level
    - Configurable using the left and right arrow keys
  - Menu Timeout (2 min)
    - Configurable using number entry screen
  - Time/Date
    - Time and date is set up as:
      - Hours: Minutes: Seconds
      - Month: Day: Year
- Ethernet Settings
  - IP Address configuration
  - Subnet Mask configuration
  - Default Gateway Configuration
- Re-Scan Sensors
  - The Controller will re-scan and refresh sensor inputs

### 3.2.2.4 INFO (INFORMATION MENU)

The Information Menu provides two choices:

- System Information: details the Firmware Revision, HMI, PLC, Serial Number, and System Runtime
- System Information: Ethernet, IP Address, Subnet Mask, Default Gateway

### 3.2.3 START UP GUIDE

Install and wire the LQ800 Transmitter as described in Sections 2.3 and 2.4 above. Connect the sensor to the transmitter as described in Section 2.4. Supply power to the Model LQ800 transmitter.

Verify the proper measurement type is displayed, pH, ORP, pION, turbidity, DO, Level, or other parameter. The sensor automatically uploads the measured parameter, the calibration data, and the range of measurement to the transmitter. The default configuration of the 4-20 mA output is the range of the sensor, 0-14 pH for pH sensors, -1500 - +1500 for ORP or 0-XXXX ppm for a pION Sensor. To change the 4-20 mA range, follow the instructions in Section 3.2.3.1 below.

### 3.2.3.1 CONFIGURE 4-20 MA OUTPUT RANGE

1. Press on top left hand corner of the channel box you would like to configure. Select Ao for Analog out
2. Press on the channel box to bring up the menu channel window
3. Press CONFIG and press on the top left blue box to manually select which Analog out you would like to configure (1 to 4 Ao)
4. Press on the blue box next to Name and manually name the Analog out
5. Press on the blue box next to Assigned to, to manual select which output should be used (Sensor, mA Inputs, Dig Inputs, COM)
6. Press on the blue box next to 4 mA. Select the value you would like to set the 4 mA output
7. Press on the blue box next to 20 mA. Select the value you would like to set the 20 mA output
8. Press save

### 3.2.3.2 SENSOR START UP

All sensors are supplied with protective caps over the sensing end. Remove the cap(s) from the sensor before installing in the process. All sensors were calibrated at the factory before shipment, no calibration should be necessary before use. Allow the sensor to equilibrate to the process solution conditions for ½ hours before verifying the reading against a grab sample. If calibration is required, follow the instruction in Section 4.0 below.

## 4.0 CALIBRATION

The HYDRA-DS Nitrate Analyzer was calibrated at the factory using the Two Point Calibration described below, and was assembled and placed beaker of equilibration solution for 8-12 hours before starting the calibration. The Chloride Ion and Nitrate Ion electrodes sensing membranes require several hours to properly hydrate/equilibrate to the measured solution. The calibration sets the zero potential and slope for each of the sensors into the analyzers memory.

Since the factory calibration characterizes the complete measurement system the initial user calibration should only require a standardization of the Nitrate Ion Electrode once the HYDRA-DS has equilibrated to the process solution.

The Factory Calibration and all subsequent calibrations should be performed in the following sequence:

1. Temperature Calibration
2. Chloride Electrode calibration in 1 ppm (or 10 ppm) and 100 ppm solutions (2 point)
3. Nitrate Electrode calibration in 1 ppm (or 10 ppm) and 100 ppm solutions (2 point)

Calibration checks should be performed weekly by comparison to a grab sample or immersing the HYDRA-DS sensor into a standard solution with known pH, Cl, and NO<sub>3</sub>-N values. Performing a Single Point Calibration will eliminate any offset found in the calibration check. Continuous drifting of the potassium or ammonium ion reading may indicate the electrode to be replaced (see Section 6.0 Troubleshooting below).

Two Point Calibration is required whenever an electrode is replaced, pH, Chloride, or Nitrate. Two Point Calibrations are also recommended every two months to verify the response of the electrodes is greater than 50 mV/decade.

### 4.0.1 RECOMMENDED MATERIALS

#### Ion Calibration Solutions

- 1 ppm Cl, 500 ml (Part# 2020453)
- 100 ppm Cl, 500 ml (Part# 2010454)
- 1 ppm NO<sub>3</sub>-N, 500 ml (Part# 2010451)
- 100 ppm NO<sub>3</sub>-N, 500 ml (Part# 2010452)

### pH Calibration Solutions (optional)

- pH 4.01, 500 ml (Part# 2010100) or 1.00 ppm NH<sub>4</sub>-N (Part# 2010445)
- pH 7.00, 500 ml (Part# 2010101) or 100 ppm NH<sub>4</sub>-N (Part# 2010446)

### Accessories

- 1 liter plastic beakers
- Distilled Water for rinsing
- Calibrated thermometer with 0.1 °C graduations
- Stir plate with magnetic stir bars

#### 4.0.2 TEMPERATURE CALIBRATION

Place the HYDRA-DS sensor in a beaker of water so that the bottom 3 inches (7.6 cm) of the body is immersed. Allow the sensor to equilibrate for 10 minutes. Verify the displayed temperature agrees with the thermometer. If not, then adjust the temperature in the Configure/Trim > °C/°F & temp cal > 1 Trim °C menu to agree with the thermometer. This calibration was performed in the factory calibration, but it is advisable to perform a temperature check every 2-3 months.

#### 4.0.3 SINGLE POINT CALIBRATION

Single Point Calibrations are used to standardize the sensor's reading to a known value typically to eliminate errors caused by drift or large changes in the makeup of the measured solution. A Single Point Calibration adjusts the base potential of the sensor by shifting the response curve to a higher or lower level, but it does not affect the slope (mV/ppm) of the curve.

Single Point Calibration is available for each of the measured parameters in the appropriate Buffer Menu, Channel 1 Buffer for the NO<sub>3</sub>-N, Channel 2 Buffer for the Cl and Channel 3 Buffer for pH or NH<sub>4</sub><sup>+</sup> (see the Single Point Calibration Screen table below).

Immerse the front end of the sensor into a container of the calibration solution, enter the value of the calibration solution or the value derived from a grab sample into the "1 (ion) xxx ppm" line of the Buffer Menu. Accept the reading when stable by pressing either of the MENU SELECT keys. The lower line in the menu, the Cal line will show the new mV value associated with the entry.

**\*\*\*Important Note for Ammonium Calibrations\*\*\*** When using the 1 ppm and 100 ppm NO<sub>3</sub>-N calibration solutions to calibrate the HYDRA-DS analyzer the potassium ion compensation, the "Cl comp" line in the Channel 1 Setup menu should be turned on, it is on by default.

If the Single Point Calibration is the first point in a Two Point Calibration it is customary to use the solution with the lowest value for the single point calibration. There are no restrictions on the value entered in the "1 (ion) xxx ppm" line of the Buffer menu it can be higher or lower than the value in line 2 of the menu. For the pH calibration the zero point is set with pH 7.0 calibration buffer and the slope is set with the pH 4.01 calibration buffer.

### Single Point Calibration Screens

Channel	Screen	Recommended Solution
Ch1 Buffer (NO <sub>3</sub> -N)	1NO <sub>3</sub> -N 1.000 ppm	1.0 ppm NO <sub>3</sub> -N (Part# 2010451) or Grab Sample value
	Cal 460.0 mV	
Ch2 Buffer (Cl <sup>-</sup> )	1 Cl <sup>-</sup> 1.000 ppm	1.0 ppm Cl (Part# 2010453) or Grab Sample value
	Cal 165 mV	
Ch3 Buffer (pH)	1 pH 7.00 pH	pH 7.0 Buffer (Part# 2010101) or Grab Sample value
	Cal 3.1 mV	
Ch3 Buffer (NH <sub>4</sub> -N)	1NH <sub>4</sub> -N 1.000 ppm	1.0 ppm NH <sub>4</sub> -N (Part# 2010445) or Grab Sample value
	Cal 320.0 mV	

#### 4.0.4 TWO POINT CALIBRATION

The second point of a Two Point Calibration sets the slope of the sensor, the mV per decade. The slope is calculated by comparing the millivolt values and ppm values in the “1NO<sub>3</sub>-N 1.00 ppm” line to the values in the “2NO<sub>3</sub>-N 100 ppm” line of the Buffer Menu. The concentration of the solution used for the second point should be at least 10 times higher than the value used in the first point of the calibration. The recommended calibration standards for both the ammonium ion and potassium ion calibrations are 1 ppm and 100 ppm. Perform a two point calibration whenever an electrode is replaced.

After completing the single point calibration, see Section 4.0.3 above, rinse the sensor with distilled water and gently dab it dry with a paper towel or soft tissue. Carefully cleaning the sensor prevents either in the calibration due to carryover from the first solution. Place the sensor in the second solution, either the pH 4.01 buffer or one of the 100 ppm solutions and wait for the reading to stabilize before accepting the value.

#### 4.0.5 CHLORIDE ION COMPENSATION

Chloride ions have a positive interference on the Nitrate Ion Electrode, the nitrate reading is higher than the actual value. The Chloride Ion Compensation, Cl comp, adjusts the measured nitrate ion concentration using the measured chloride concentration and the interference/selectivity value, the Cl coef, and subtracts the resulting amount from the Nitrate Ion Signal. The Cl coef value in the NO<sub>3</sub>-N Set Up screen allows the interference ratio to be adjusted as needed. The default setting is Cl coef = .004 which is 250 chloride ions produce the same signal as 1 nitrate ion, K<sub>s</sub> = 0.04 would change the correction to 25:1. The 0.004 correction factor is good for most solutions with levels of chloride greater than 50 ppm.

Each Chloride Ion Electrode should have similar characteristics but adjustments are necessary when the chloride electrode is replaced or when low levels of chloride are present in the solution. If the nitrate ion concentration is less than expected when compared to a grab sample measurement then adjust the Cl coef value to a smaller value. Adjusting from 0.004 > 0.002 for example would increase the chloride to nitrate ion ratio from 250:1 to 500:1 thereby slightly increasing the displayed nitrate ion concentration by subtracting less in the compensation.

### 4.1 CALIBRATION – T80 TRANSMITTER

The Model T80 transmitter provides three methods of calibration:

#### 4.1.1 AUTO CALIBRATION DESCRIPTION

AUTO calibration is the primary calibration method for all measurements. AUTO calibration automatically recognizes the calibration solution the sensor is in, and proposes the actual temperature compensated value for acceptance. AUTO calibration can be a single point or two point calibration. A single point calibration sets the zero point or offset value of the sensor. The second calibration sets the slope or span of the sensor.

When the AUTO key is pressed, the transmitter displays the PV (Process Value) and the associated mV signal from the sensor. When the reading has stabilized a calibration value is automatically proposed (i.e. 7.00 pH, 10 ppm Fluoride ion, 0.00 mg/L Dissolved Oxygen). **The user is prompted to accept the proposed calibration value or enter and accept another value.** Once Cal 1 is accepted, the user is asked to continue to Cal 2 (YES/NO). If yes, then a second calibration is proposed. When the sensor has stabilized in the second calibration solution, accept the value and the calibration is complete.

At the end of each calibration, the Offset and Slope are displayed in the respective units: pH, mV, ppm, and mg/l.



#### 4.1.2 STANDARDIZE CALIBRATION DESCRIPTION

A Standardize Calibration is a single point calibration where the transmitter's reading is adjusted to agree with a solution of known value, either a calibration standard, a grab sample or laboratory determined value. In many cases the constituents and the pressure and temperature of the process solution are very different from calibration solution. In these cases, once the sensor has equilibrated, the Zero Point or Offset value may have shifted from the original calibration point. Standardization allows for correction of this type of offset.

When the STAND key is pressed, the user is prompted to ENTER VALUE. The user enters the value they want the transmitter to read and press OK. The user is then prompted to accept the value (YES/NO), and the calibration is complete. Standardizations are single point calibrations.

At the end of each calibration, the Offset and Slope in the respective units: pH, mV, ppm, and mg/l.

#### 4.1.3 MANUAL CALIBRATION DESCRIPTION

Manual calibration allows the user to enter calibration data for an electrode into the transmitter without performing a calibration. A MANUAL Calibration requires the entry of three pieces of data, (1) A **concentration** with the (2) **corresponding mV** value, and (3) a **slope** for the electrode. This allows laboratory generated calibration data for an electrode to be entered in a remote analyzer where calibration is difficult or impractical.

Example: MANUAL Calibration for a pH electrode

1. Calibrate the pH electrode in the laboratory
2. Record the mV value of some pH Standard, pH 7.00 buffer = 6.8 mV (any pH – mV pair will work)
3. Calculate and Record the slope of the electrode, -58.2 mV/pH
4. Install the electrode into the field mounted sensor
5. **Press MANUAL** and enter the pH value, 7.00 pH, **press mV**, and enter the corresponding mV value, 6.8 mV, press OK, Accept Offset?, press YES, enter slope – 58.2 mV/pH, **press OK**, Accept Slope?, **Press YES**
6. The Calibration is complete, the Offset and Slope values are displayed, **press OK** to exit.

## 4.2 CALIBRATION – LQ800 TRANSMITTER

The Model LQ800 transmitter provides three methods of calibration:

#### 4.2.1 AUTO CALIBRATION DESCRIPTION

Auto Calibration is the primary calibration method for all measurements. AUTO calibration automatically recognizes the calibration solution the sensor is in, and proposes the actual temperature compensated value for acceptance. AUTO calibration can be a single or two point calibration. A single point calibration sets the zero point, or offset value, of the sensor. The second calibration sets the slope of the sensor.

When the AUTO keys is pressed, the transmitter displays the PV (Process Variable) and the associated mV signal from the sensor. When the reading has stabilized a calibration value is AUTOMATICALLY proposed, i.e. 7.00 pH, 100 ppm Fluoride ion, 0.00 mg/L Dissolved Oxygen. The user is prompted to accept the proposed calibration value or enter and accept another value. Once Cal 1 is accepted, the user is asked to continue to Cal 2 (YES/NO). If yes, then a second calibration value is proposed when the sensor has stabilizes in the second calibration solution. Accept the value and the calibration is complete.

At the end of each calibration, the Offset and Slope are displayed in the respective units, pH, mV, ppm, mg/l.

#### 4.2.2 STANDARDIZE CALIBRATION DESCRIPTION

A Standardize Calibration is a single point calibration where the transmitter's reading is adjusted to agree with a solution of known value, either a calibration standard, a grab sample, or a laboratory determined value. In many cases the constituents, the pressure, and the temperature of process solution are very different from the calibration solution. In these cases, once the sensor has equilibrated the Zero Point, or Offset value, may have shifted from the original calibration point. Standardization allows for correction of this type of offset.

When the STAND key is pressed, the user is prompted to ENTER VALUE. The user enters the value they want the transmitter to read and press OK. The user is then prompted to accept the value (YES/NO), and the calibration is complete. Standardizations are single point calibrations.

At the end of each calibration the Offset and Slope are displayed in the respective units: pH, mV, ppm, or mg/l.

#### 4.2.3 MANUAL CALIBRATION DESCRIPTION

Manual calibration allows the user to enter calibration data for an electrode into the transmitter without performing a calibration. A MANUAL Calibration requires the entry of three pieces of data: (1) A concentration with the (2) corresponding mV and (3) a slope for the electrode. This allows laboratory generated calibration data for an electrode to be entered in a remote analyzer where calibration is difficult or impractical.

Example: MANUAL Calibration for a pH electrode

1. Calibrate the pH electrode in the laboratory
2. Record the mV value of some pH Standard, pH 7.00 buffer = 6.8 mV (any pH – mV pair will work)
3. Calculate and Record the slope of the electrode, -58.2 mV/pH
4. Install the electrode into the field mounted sensor
5. Press MANUAL and enter the pH value, 7.00 pH, press mV, and enter the corresponding mV value, 6.8 mV, press OK, Accept Offset?, press YES, enter slope -58.2 mV/pH, press OK, Accept Slope?, Press YES
6. The Calibration is complete, the Offset and Slope values are displayed, press OK to exit

#### 4.2.4 CAL (CALIBRATION MENU)

Four options are available, **AUTO**, **STAND**, **MANUAL**, and **TEMP**.

- **AUTO** is a two point calibration. The calibration proceeds in two steps, AutoCal 1 is an offset calibration and AutoCal 2 is a slope calibration. Auto Cal provides automatic solution recognition of the calibration solutions used for each measurement in accordance with the following list:

1. pH Calibration Buffers (US Standard), pH 4.01, pH 7.00, and pH 10.00 (see Appendix A)
2. ORP Calibration Solutions: Quinhydrone saturated: pH 7.00 = +89 mV, pH 4.01 = +266 mV
3. Ion Calibration Solutions: 1.00, 10.00, 100.00 ppb, ppm, ppt (thousand)
4. Dissolved Oxygen: Zero ppm (Sodium sulfite, Na<sub>2</sub>SO<sub>3</sub> in water), Air saturated water, 8.25 ppm

Any two solutions can be used for AUTO calibration however if solutions other than those listed above are used for calibration then the calibration values must be entered manually.

- **STAND** is standardization, a single point calibration. Standardizations are typically used to adjust the process reading to agree with a laboratory determined "grab sample" reading.
- **MANUAL** is a data entry screen. Manual calibration allows the user to enter a concentration with the corresponding mV value, and a slope for an electrode. Laboratory generated calibration data for an electrode can be input to a remote analyzer where calibration is difficult or impractical.
- **TEMP** allows the displayed temperature to be trimmed to agree with actual process temperature.

## 5.0 MAINTENANCE

### 5.1 MAINTENANCE SCHEDULE

The HYDRA-DS sensor requires little maintenance since most of the required cleaning is accomplished by the Air Blast Spray Cleaner. Determining the proper cleaning cycle and duration for the application will keep the front end of the sensor clean for extended periods, but **weekly inspection of the sensing end** is recommended.

**Weekly calibration checks** versus a grab sample are recommended to minimize any drift in the sensor. Once the stability of the sensor has been established in the process, the time between calibration checks can be adjusted. A calibration check must occur at least one per month.

The HYDRA-DS should be checked monthly in calibration solutions for proper span of both the ammonium and potassium electrodes. The electrodes start life with a span in the 55 mV/decade range and drop off into the 40 mV/decade range as they age. Readings below 40 mV/decade indicate the electrode should be replaced. Depending on the characteristics of the water being measured the Ion Selective electrodes should last 3-6 months.

### 5.2 CLEANING THE SENSOR

The HYDRA-DS sensor can be rinsed with water and wiped with a soft brush or cloth to remove most coatings. **DO NOT** clean the potassium or ammonium ion electrodes with a stiff brush or vigorous wiping as the sensing membrane is easily torn. **DO NOT** use strong detergent solutions or Spray Class cleaners to clean the sensor, the potassium and ammonium electrodes will be irreparably harmed. The sensor can be soaked in dilute HCl, 2-3%, for 15 minutes to help remove stubborn coatings. Use a weak detergent solution, a couple of drops detergent per liter of water, to remove any oily coatings. The pH electrode and HYDRA-DS housing can be cleaned in a more rigorous manner since the plastic body and glass membrane are more durable than the Ion Selective Electrodes.

### 5.3 REPLACING THE ELECTRODES

The three electrodes—Nitrate, Chloride, and pH—are easily replaceable by simply removing the electrode guard, screwing out the old sensor and screwing in the new one using the supplied installation tool. **Make sure no water gets inside the sensor** when removing the electrodes. Water will cause the internal electronics to fail. If the electronics are compromised the HYDRA-DS sensor must be replaced.

The nitrate electrode, the chloride, and pH electrodes are combination electrodes. The reference electrodes are combined to a single signal which is for all the measurements.

Apply a thin film of o-ring lubricant to the o-rings on the electrode before installing it into the sensor housing. Use the supplied electrode installation tool to remove or install electrodes into the sensor. The use of pliers or other tools is not recommended as they may crack the electrode housing.

## 6.0 TROUBLESHOOTING

Problem	Possible Cause	Remedy
NO <sub>3</sub> -N Reading Low	Dirty Coated electrode	Clean sensor:  Soak in 2% HCU for 5 minutes to remove algae or rinse with weak detergent 10-15 seconds solution to remove oils.  Soak in tap water for 30 minutes after either cleaning method. Increase frequency of the air blast cleaner
	Old Expired NO <sub>3</sub> ISE	Perform two point calibration, the slope > 40 mV/decade if not replace NO <sub>3</sub> Sensor
	Inaccurate Potassium compensation	Verify Chloride ISE reading with single point calibration.  Adjust <b>Cl coef</b> (see section 4.0.5)
NO <sub>3</sub> -N Reading High	Ammonium Sensor has drifted	Perform a single point calibration
	Low or No Chloride ion Compensation	Verify Cl comp is ON  Verify Chloride ISE reading with single point calibration  Adjust <b>Cl coef</b> (see section 4.0.5)
	Interfering Ions Present in Sample	Influx of interfering ions causing error, wait for ions to clear the process, Iodide, Bromide, HS-, Chlorate, Chlorite, Carbonate, Bicarbonate, Nitrite
No Response to Changing Nitrate	Bad Electrode	Visual inspect membrane for cuts, if torn replace electrode  Remove the electrode examine for breakage, torn o-rings, corrosion or moisture, if any of these issues are present:  Switch out old electrode with a new electrode, check response, if good recalibrate the HYDRA-DS
	Bad Sensor	Switch out old electrode with a new electrode, check response, if still bad examine electrode tube for signs of moisture.  If present remove sensor from installation and allow the sensor to dry out. Retest with a new electrode, if it still fails return it to the factory for refurbishment.

# 7.0 ENGINEERING DOCUMENTATION

## 7.1 SPECIFICATIONS

### 7.1.1 SENSOR

Three Electrode system with spray cleaner, Nitrate ISE (NO<sub>3</sub>-N) is the primary measurement. The Chloride ISE is used to compensate the NO<sub>3</sub> signal. An optional pH electrode is available for pH measurement. The Sensor is waterproof with an ingress rating of IP 68.

#### Measurement Range

NO<sub>3</sub>-N: 0.1 to 1000 ppm

#### Operating Temperature

0°C to 40°C (32°F to 104°F)

#### Min/Max Flow Rate

Minimum 0.1 m/s

Maximum 3.0 m/s

#### Wetted Materials

PVC, PES, PVDF, PTFE, Viton, Glass, 316 SS

#### Accuracy

± 3% of reading, dependent on Calibration

#### Response Time

T90 1 minute

#### Electrode Life

ISEs: 4-6 months, typical

pH electrode: 6-12 months, typical

### 7.1.2 T80 TRANSMITTER

#### 7.1.2.1 INPUT SPECIFICATION

- Digital protocol, all ECD S80 sensors
- Optional analog to digital converter, 5 inputs [mV+, mV-, solution ground, temp + temp – (100 K-ohm)]

#### 7.1.2.2 INPUT RANGES

pH	-1.00 – 15.00 pH
ORP	-1500 – +1500 mV
pION	000.1 – 999.9, Auto Ranging: ppb ↔ ppm ↔ ppT (thousand)
Dissolved Oxygen	000.1 – 999.9, Auto Ranging: ppb ↔ 20.00 ppm, % SAT, mg/L
Conductivity	0.000 – 2.000, Auto Ranging: μS ↔ mS ↔ S TDS 0.00 – 9999ppm
Resistivity	0.00 – 50.00 MΩ
Turbidity	0 – 4000 NTU/FNU, 0 – 9999 ppm, mg/l, 0 – 100% % solids
Temperature	100 K-ohm TC, -30°C – 140°C

### 7.1.2.3 ACCURACY

<b>PH</b>	-1.00 – 15.00 PH
<b>ORP</b>	-1500 – +1500 MV
<b>PION</b>	000.1 – 999.9, AUTO RANGING: PPB ↔ PPM ↔ PPT (THOUSAND)
<b>DISSOLVED OXYGEN</b>	000.1 – 999.9, AUTO RANGING: PPB ↔ 20.00 PPM, % SAT, MG/L
<b>CONDUCTIVITY</b>	0.000 – 2.000, AUTO RANGING: μS ↔ MS ↔ S TDS 0.00 – 9999 PPM
<b>RESISTIVITY</b>	0.00 – 50.00 MΩ
<b>TURBIDITY</b>	0 – 4000 NTU/FNU, 0 – 999 PPM, MG/L, 0 – 100% % SOLIDS
<b>TEMPERATURE</b>	100 K-OHM TC, -30°C – 140°C

### 7.1.2.4 OUTPUT SIGNALS

- Non-isolated 4-20 mA output (standard, one per Channel), Fault Condition: 3.5 mA, 22 mA, or none
- Modbus RTU (standard)
- HART® (optional)

### 7.1.2.5 CONTACT RELAYS

(Optional) Three (3) SPDT, 1 form C, 250 VAC, 10 Amp resistive maximum, relays, user configurable as Hi/Lo alarms with expiration timer, Periodic Timers or Fault alarms

### 7.1.2.6 DISPLAY

128 x 64 pixels (2.75" x 1.5") LCD, Black on Grey background on loop powered instruments, Blue on White background with LED backlight on 100-250 VAC and 24 VDC powered instruments, English or icon based menus, numeric and graphical displays.

### 7.1.2.7 ENCLOSURE

Beige Polycarbonate, IP65, weatherproof, ½ DIN, (L x W x D) 5.7" x 5.7" x 3.5" (14.4cm x 14.4cm x 9.0cm)

### 7.1.2.8 POWER

- Code -0 Loop powered, 24 VDC 600 Ω maximum load (18-36VDC @ 0.3W Maximum)
- Code -1 24 VDC (18-36 VDC @ 4W Maximum)
- Code -2 100-240 VAC, 50/60 Hz, 4W, protected with 250V, 1A, Slow Blow fuse

### 7.1.2.9 ENVIRONMENTAL CONDITIONS

Outdoor use (IP65)	
Ambient Temperature	-20°C – 70°C (24 VDC Models) -20°C – 60°C (100-240 VAC Models)
Storage Temperature	-30°C – 85°C
Relative Humidity	0 – 80%, up to 31°C Decreasing linearly to 50% RH a 40°C
Altitude	Up to 2000 m (6500 ft)
Mains Supply Voltage	Fluctuations up to ±10% of the nominal voltage Transient over voltages: CAT II Pollution Degree: 2

### 7.1.2.10 SHIPPING

Size	8" x 8" x 5" (20.5cm x 20.5cm x 12.7cm)
Weight	1.6 lbs. (0.75 kg)

7.1.3 MODEL CODES

Model T80-							
1 <sup>st</sup> Channel	1 (S80) S80 Digital Sensor, pH, ORP, pION, DO, DO90 ppb DO, Conductivity, Resistivity						
	2 Internal Preamp, Digital to S10/S17 pH, ORP, pION (+mV, -mV, 100K TC, SG)						
	3 Internal Preamp, Digital to SGTC Conductivity/Resistivity (CSX2 or 2 electrode contacting)						
	4 Internal Preamp, Digital to SGTC Dissolved Oxygen (Steam Sterilizable Products)						
	2 <sup>nd</sup> Channel	0 No Second Channel					
		1 (S80) S80 Digital Sensor, pH, ORP, pION, DO Conductivity, Resistivity					
		Power Supply	-0 Loop Powered Transmitter				
			-1 24 VDC Powered Transmitter				
			-2 100-240 VAC Powered Transmitter				
		Relay Option	0 No relays				
			1 (3) form 1C 250 V 3A relays				
		Outputs	0 4-20 mA output and MODBUS				
			1 HART®				
			2 2 x 4-20 mA & MODBUS				
Mounting Hardware		00 No Mounting					
		01 Universal					
		02 Panel Mount					
	03 Handrail Mount						
	04 Sunshield Pole						
05 Sunshield Rail							
<b>Model T80-</b>	<b>1</b>	<b>1</b>	<b>-2</b>	<b>1</b>	<b>2</b>	<b>01</b>	

Example above shows # T80-11-212-01, a two channel T80 transmitter for use with two S80 sensors, 110/220 VAC powered with two 4-20 mA outputs and MODBUS RTU and a universal mounting bracket.

## 7.2 INSTALLATION

### 7.2.1 MOUNTING

Mount the T80 in a location where there is easy access to the analyzer and sensors. Install the system in an area where vibrations, electromagnetic and radio frequency interference are minimized or absent. Do not mount in direct sunlight or areas of extreme heat (temperature > 120°F). The IP65 T80 is suitable for outdoor use but it is best to mount it with a protective cover or sunshield to prevent discoloring over the years.

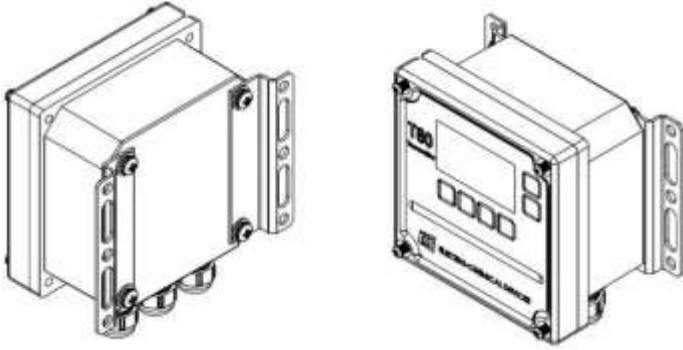

Universal Mounting Brackets

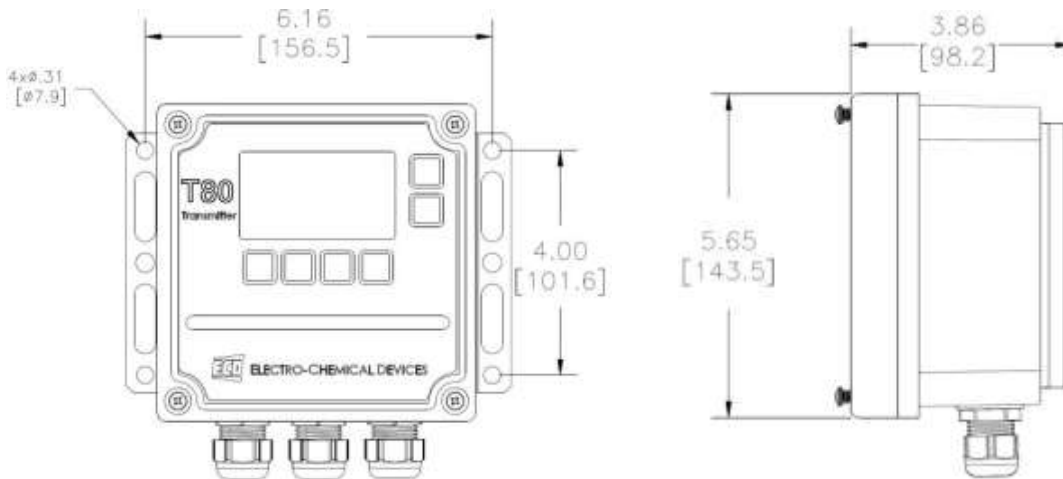

Rail Mounting

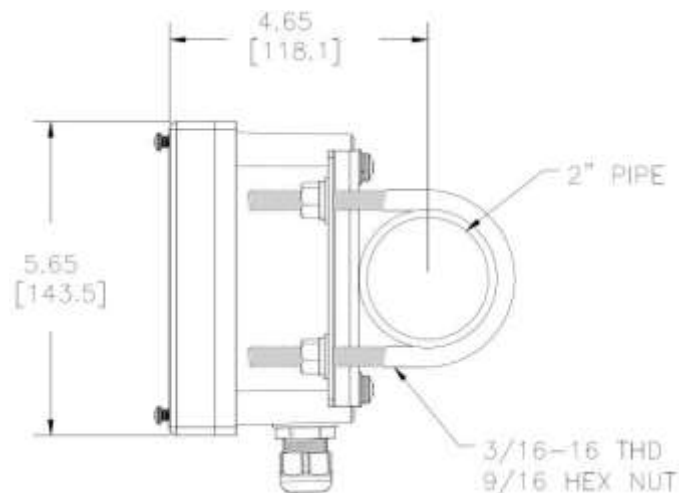
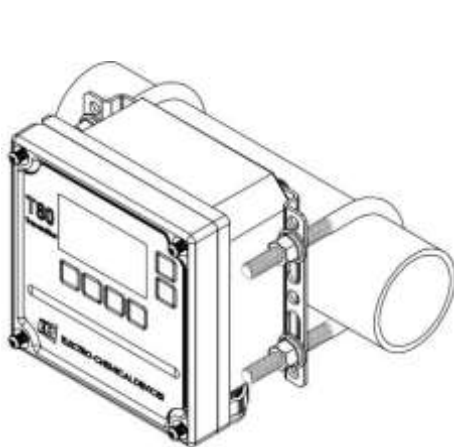

Panel Mounting



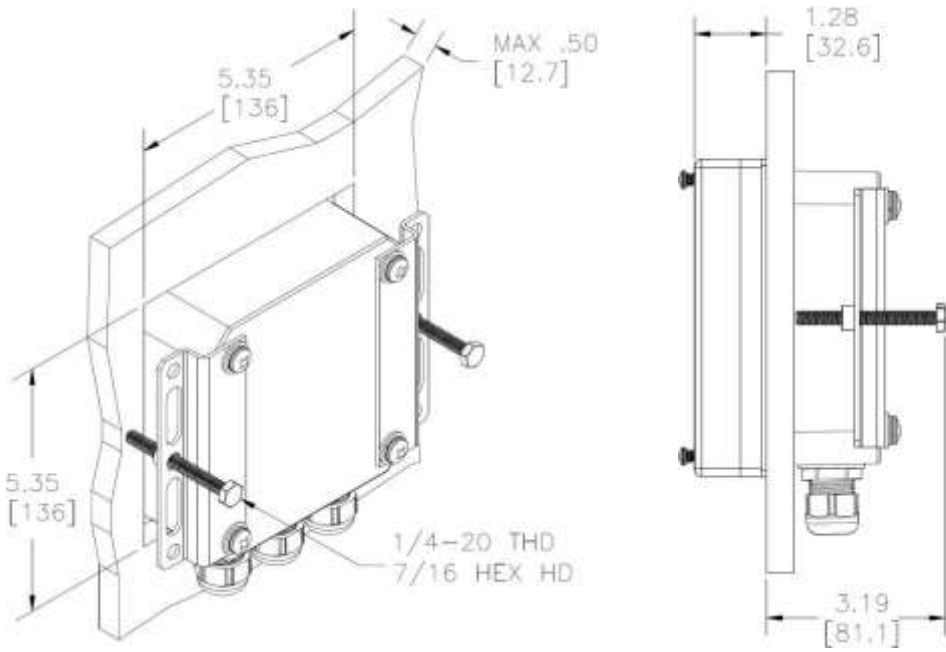

Cut Out: 5.35" x 5.35" (13.6 cm x 13.6 cm)

## 7.2 HYDRA-DS SENSOR DIMENSIONAL DRAWING

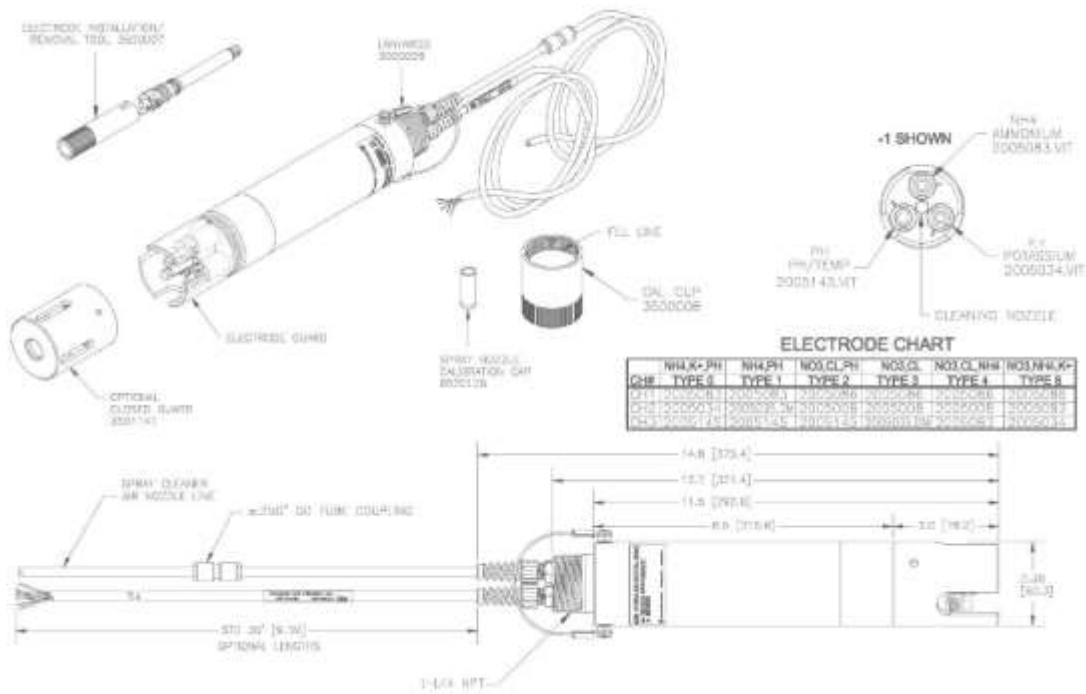

ELECTRODE CHART

GH#	TYPE 0	TYPE 1	TYPE 2	TYPE 3	TYPE 4	TYPE 5
NH4K-PH	NH4PH	NO3CLPH	NO3CL	NO3CLNH	NO3NHLY	
2000000000	2000000000	2000000000	2000000000	2000000000	2000000000	2000000000
2000000000	2000000000	2000000000	2000000000	2000000000	2000000000	2000000000
2000000000	2000000000	2000000000	2000000000	2000000000	2000000000	2000000000

## 8.0 ORDERING INFORMATION

### 8.1 PART NUMBERS/MODEL NUMBERS

Part No.	Models and Products Description
1290130-3	HYDRA-DS NO3-N Digital Sensor Complete NO3, Cl-, pH, Temp, Spray Cleaner head, and 30 ft. cable
1290130-4	HYDRA-DS NO3-N Digital Sensor Complete NO3, Cl-, Temp, Spray Cleaner head, and 30 ft. cable

### 8.2 ACCESSORIES

Part No.	Accessories Description
1000254-XX	Immersion Assembly, 1 ¼" Slip x 45°, 1 ¼" NPT sensor connection and 1 ½" Slip x Cable feed through Elbow End Cap, <b>XX = Length in ft.</b>
1000254-99	Immersion Assembly, 1 ½" Slip by 45° 1 ¼" NPT sensor connection and 1 ½" Slip x Cable feed through Elbow End Cap, <b>Fittings Only, User supplied Pipe (1 ½" Pipe)</b>
2000255-1	2" Handrail Swivel Mounting Bracket
9860002	Clamp Pipe Mount 2" HYDRA-DS

### 8.3 CALIBRATION SOLUTIONS

Part No.	Accessories Description
2010444-1	Solution K+ 100 ppm HYDRA
2010446-1	Solution NH4-N 100 ppm HYDRA
2010476-1	NH4-N Sol 10 ppm HYDRA
2010500-1	Kit, Calibration, HYDRA, NH4, K and pH
2010500-2	Kit, Calibration, HYDRA, NH4 and pH
2010510-1	Kit, Calibration, HYDRA, NO3, CL, and pH
2010510-2	Kit, Calibration, HYDRA, NO3, CL
2010510-3	Kit, Calibration, HYDRA, NO3, CL, NH4

### 8.4 SPARE PARTS

Part No.	Accessories Description
2005008.VIT	Chloride Electrode Cartridge (recommended spare)
2005084.VIT	Ammonium Electrode Cartridge (recommended spare)
2005086.VIT	Nitrate Electrode Cartridge (recommended spare)
2005145.VIT	pH Electrode Cartridge (recommended spare)
3000026	Lanyard HYDRA Assembly
3300854-1	Replacement Spray Nozzle
3500007	Electrode Replacement Tool
3500008	Cal Cup HYDRA
3501050-1	Guard HYDRA 2.5in PVC
3501078-1	PVC Front Sensor Guard
3501078-1	Guard HYDRA Clear PVC
3501141	Closed Guard HYDRA Gray PVC

# APPENDIX

## A. AUTO CAL BUFFER TABLES

°C	pH	pH	pH
0	4.00	7.115	10.32
5	4.00	7.085	10.25
10	4.00	7.06	10.18
15	4.00	7.04	10.12
20	4.00	7.015	10.06
25	4.005	7.00	10.01
30	4.015	6.985	9.97
35	1.025	6.98	9.93
40	4.03	6.975	9.89
45	4.045	6.975	9.86
50	4.06	6.97	9.83
55	4.075	6.97	
60	4.085	6.97	
65	4.10	6.98	
70	4.13	6.99	
75	4.14	7.01	
80	4.16	7.03	
85	4.18	7.05	
90	4.21	7.08	

## B. T80 HART MENU

T80 Root Menu						
	1 DEVICE SETUP	DEVICE SETUP	CALIBRATION			
	1 CALIBRATION		1 AUTO			
			2 STANDARDIZE			
			3 MANUAL			
			4 TEMP			
	2 BASIC SETUP		CONFIG			
			1 XMTR	XMTR CONFIG	ANALOG CONFIG	
			1 ANALOG		1 SCALE	ANALOG SCALE
					1 UPPER	
					2 LOWER	
			2 PID		PID CONFIG	
					1 P Term	
					2 I Term	
			3 CALIBRATE		3 D Term	
CALIBRATE						
1 Zero cal						
1 Gain cal						
			3 Save			

			2 ALARMS	ALARM CONFIG				
				1 Alrm 1 thresh				
				2 Alrm 1 hyst				
				3 Alrm 1 dly on				
				4 Alrm 2 thresh				
				6 Alrm 2 hyst				
				7 Alrm 2 dly on				
				8 Alrm 2 dly off				
				9 Alrm 3 thresh				
				10 Alrm 3 hyst				
				11 Alrm 3 dly on				
				12 Alrm 3 dly off				
				3 Address				
	2 Device information			2 Device information	DEVICE INFORMATION			
					1 Distributor			
					2 Model			
					3 Dev ID			
					4 Cfg chng count			
					5 Tag			
					6 Long tag			
7 Date								
9 Descriptor								
10 Message								
11 Final asmbly num								
3 INFORMATION				INFORMATION				
				1 XMTR			1 XMTR	XMTR INFO
								1 Serial #
								2 FW Rev
								3 HW Rev
								4 Fld dev rev
				2 SENSOR			2 SENSOR	SENSOR INFO
								1 Serial #
								2 FW Rev
				3 DEVICE			3 DEVICE	DEVICE INFORMATION
								1 Distributor
								2 Model
								3 Dev ID
								4 Cfg chng count
								5 Tag
								6 Long tag
								7 Date
9 Descriptor								
10 Message								
11 Final asmbly num								
2 PV								
3 Temperature								
4 Output %								
5 Sensor Name								

## C. MODBUS RTU REGISTER LISTING

### 03 (0x03) Read Holding Registers

This function code is used to read the contents of a contiguous block of holding registers in a remote device. The Request Protocol Data Unit specifies the starting register address and the number of registers. In the Protocol Data unit Registers are addressed starting at zero. Therefore registers numbered 1-16 are address as 0-15.

The register data in the response message are packed as to byte per register, with the binary contents right justified within each byte. For each register, the first byte contains the high order bits and the second contains the low order bits.

Request		
Modbus ID (Slave Address)	1 Byte	1 to 247 (0x01 to 0xF7)
Function code	1 Byte	0x03
Starting Address	2 Bytes	0x0000 to 0xFFFF
Quantity of Registers	2 Bytes	1 to 125 (0x01 to 0x7D)
CRC	2 Bytes	calculated

Request		
Modbus ID (Slave Address)	1 Byte	1 to 247 (0x01 to 0xF7)
Function code	1 Byte	0x03
Byte Count	1 Byte	2 x N*
Register Value(s)	*N x2 Bytes	
CRC	2 Bytes	calculated

\*N = Quantity of Registers

Error		
Modbus ID (Slave Address)	1 Byte	1 to 247 (0x01 to 0xF7)
Error Code	1 Byte	0x86
Exception Code	1 Byte	01, 02, 03, or 04
CRC	2 Bytes	calculated

### 06 (0x06) Write Single Register

This function code is used to write a single holding register in a remote device. The Request Protocol Data Unit specifies the address of the register to be written. Registers are addressed starting at zero. Therefore register number 1 is addressed as 0. The normal response is an echo of the request, returned after the register contents have been written.

Request		
Modbus ID (Slave Address)	1 Byte	1 to 247 (0x01 to 0xF7)
Function code	1 Byte	0x06
Register Address	2 Bytes	0x0000 to 0xFFFF
Register Value	2 Bytes	0x0000 to 0xFFFF
CRC	2 Bytes	calculated

Response		
Modbus ID (Slave Address)	1 Byte	1 to 247 (0x01 to 0xF7)
Function code	1 Byte	0x06
Register Address	2 Bytes	0x0000 to 0xFFFF
Register Value	2 Bytes	0x0000 to 0xFFFF
CRC	2 Bytes	calculated

\*N = Quantity of Registers

Error		
Modbus ID (Slave Address)	1 Byte	1 to 247 (0x01 to 0xF7)
Error Code	1 Byte	0x86
Exception Code	1 Byte	01, 02, 03, or 04
CRC	2 Bytes	calculated

## Registers

Per the Modbus Application Protocol Specification (V1.1b)

Name	Meaning (2 bytes each register)	Number of Registers	Return Data Format	Read Write	Requires Storage Initiate	Register #	
						dec	hex
Modbus ID (slave address)	Defined as 1 to 247 per the Modbus Application Protocol Specification (V1.1b)	1	16 bit Integer	RW		0	00
Data Format	Data Format of the User Bus to the T80 (0-DF8N2, 1-DF8O1, 2-DF8E1, 3-DF8N1)	1	16 bit Integer	RW		1	01
Baud Rate	Baud Rate of the User Bus to the T80 (0-1200, 1-2400, 2-4800, 3-9600)	1	16 bit Integer	RW		2	02
BusMessage	total message count detected by the slave (remote device)	1	16 bit Integer	R		3	03
BusCommunicationsError	total CRC error count	1	16 bit Integer	R		4	04
SlaveExceptionError	total count of exceptions detected	1	16 bit Integer	R		5	05
SlaveMessage	total messages addressed to the slave (remote device)	1	16 bit Integer	R		6	06
SlaveNoResponse	total count of messages not responded to by the slave (remote device)	1	16 bit Integer	R		7	07
SlaveNAK	total Negative Acknowledges returned by slave (remote device)	1	16 bit Integer	R		8	08
SlaveBusy	total count of "slave busy" was returned for an address message	1	16 bit Integer	R		9	09
BusCharacterOverrun	count of messages that couldn't be handled due to character over-run condition	1	16 bit Integer	R		10	0A
Reset all Modbus Error Counters	Resets all of the Modbus Error counters (defined in Modbus spec) to 0, Write any value.	1	16 bit Integer	W		11	0B
Product T80 Model Number (Modbus)	The Model Number of the Unit polled	1	16 bit Integer	R		12	0C
T80 Serial Number (hi word)	Unit Serial Number (32 bit integer hi word, bytes 3 and 2)	2	32 bit Long Integer	R		13	0D
T80 Serial Number (lo word)	Unit Serial Number (32 bit integer lo word, bytes 1 and 0)					14	0E
T80 Mode	Unit operating mode (1-Startup, 2-Sensor Search, 3-Operate)	1	16 bit Integer	R		15	0F
T80 Fault Status	Unit Fault flags, bit defined	1	16 bit Integer	R		16	10
T80 2nd Fault Status	Unit Fault flags (2nd word reserved, currently not used)	1	16 bit Integer	R		17	11
T80 Warning Status	Unit Warning flags, bit defined	1	16 bit Integer	R		18	12
T80 2nd Warning Status	Unit Warning flags (2nd word reserved, currently not used)	1	16 bit Integer	R		19	13
T80 FW Rev	Firmware revision of the Control BD in ASC, ex. " 1".	1	16 bit Integer	R		20	14
Relay Number to read/write	Relay number to access data (0 - Relay 1, 1 - Relay 2, 2 - Relay 3)	1	16 bit Integer	RW		21	15
Relay Type	Read/Write Relay Type (0 - Fault Type, 1 - Alarm Type, 2 - Disabled, 3 - Timed)	1	16 bit Integer	RW	Y	22	16

Relay ON Setpoint (hi word)	Read/Write Relay ON Setpoint (byte 3 and byte 2)	2	32 bit Floating Point	RW	Y	23	17
Relay ON Setpoint (lo word)	Read/Write Relay ON Setpoint (byte 1 and byte 0)					24	18
Relay OFF Setpoint (hi word)	Read/Write Relay OFF Setpoint (byte 3 and byte 2)	2	32 bit Floating Point	RW	Y	25	19
Relay OFF Setpoint (lo word)	Read/Write Relay OFF Setpoint (byte 1 and byte 0)					26	1A
Relay ON Delay (hi word)	Read/Write Relay turn on Delay time (byte 3 and byte 2)	2	32 bit Floating Point	RW	Y	27	1B
Relay ON Delay (lo word)	Read/Write Relay turn on Delay time (byte 1 and byte 0)					28	1C
Relay OFF Delay (hi word)	Read/Write Relay turn off Delay time (byte 3 and byte 2)	2	32 bit Floating Point	RW	Y	29	1D
Relay OFF Delay (lo word)	Read/Write Relay turn off Delay time (byte 1 and byte 0)					30	1E
Relay Energized State	Read/Write Relay 0 - Energized, 1 - De-Energized	1	16 bit Integer	RW	Y	31	1F
Relay Expiration	Read/Write Expiration Time, used with alarm type (0 - None, 2 - 5min., 3 - 10min., 4 - 15min., 6 - 30min.)	1	16 bit Integer	RW	Y	32	20
Relay Period	Read/Write Timed Relay Period (0 - 15min., 1 - 30min., 2 - 1hr., 3 - 2hr., 4 - 4hr., 5 - 8hr., 6 - 24hr.)	1	16 bit Integer	RW	Y	33	21
Relay Duration	Read/Write Timed Relay Duration (0 - 15sec., 1 - 30sec., 2 - 1min., 3 - 2min., 4 - 5min., 5 - 15min., 6 - 10min.)	1	16 bit Integer	RW	Y	34	22
Relay Hold Time	Read/Write Timed Relay Hold Time (0 - Off, 1 - held for the duration time, 2 - duration + 15sec., 3 - duration + 30sec., 4 - duration + 1min., 5 - duration + 2min., 6 - duration + 5 min., 7 - duration + 15min., 8 - duration + 30min.)	1	16 bit Integer	RW	Y	35	23
4-20 mA Channel Number to read/write	4-20 mA channel number to access data (0 - 1st 4-20mA, 1 - 2nd 4-20)	1	16 bit Integer	RW	Y	36	24
4-20 Analog Type	Read/Write 4-20 Type (0 - Range, 1 - Temperature, 2 - Sentinel)	1	16 bit Integer	RW	Y	37	25
4-20 Analog Range, 4mA range (hi word)	Read/Write 4mA range (bytes 3 and 2) applies to both range and temperature types	2	32 bit Floating Point	RW	Y	38	26
4-20 Analog Range, 4mA range (lo word)	Read/Write 4mA range (bytes 1 and 0) applies to both range and temperature types					39	27
4-20 Analog Range, 20mA range (hi word)	Read/Write 4mA range (bytes 3 and 2) applies to both range and temperature types	2	32 bit Floating Point	RW	Y	40	28
4-20 Analog Range, 20mA range (lo word)	Read/Write 4mA range (bytes 1 and 0) applies to both range and temperature types					41	29
Long Tag Line number to read/write	Tag Line number to access data (0 - Line 1, 1 - Line 2)	1	16 bit Integer	RW	Y	42	2A
Long Tag Line 1 (16 characters max)	ASCII character bytes 0 and 1, ex. "AB" A - 65 (41 hexadecimal), B - 66 (42 hex), send 6566 (4142 hex). The characters permitted are space ' ' (32 base 10, 20 hex) through '}' 125 base 10, 7D hex).	1	16 bit Integer	RW	Y	43	2B
Long Tag Line	ASCII bytes 2 and 3	1	16 bit Integer	RW	Y	44	2C
Long Tag Line	ASCII bytes 4 and 5	1	16 bit Integer	RW	Y	45	2D
Long Tag Line	ASCII bytes 6 and 7	1	16 bit Integer	RW	Y	46	2E
Long Tag Line	ASCII bytes 8 and 9	1	16 bit Integer	RW	Y	47	2F
Long Tag Line	ASCII bytes 10 and 11	1	16 bit Integer	RW	Y	48	30
Long Tag Line	ASCII bytes 12 and 13	1	16 bit Integer	RW	Y	49	31
Long Tag Line	ASCII bytes 14 and 15	1	16 bit Integer	RW	Y	50	32
Initiate T80 Parameter Storage	Signals the user has completed entering the data and wants it stored. Write any value.	1	16 bit Integer	RW		51	33
Sensor Channel to read/write	Sensor channel number to access data (0 - Sensor 1, 1 - Sensor 2)	1	16 bit Integer	RW		52	34
S80 Mode	Unit operating mode (0-	1	16 bit Integer	R		53	35

S80 Serial Number (hi word)	Unit Serial Number (32 bit integer hi word)	2	32 bit Long Integer	R		54	36
S80 Serial Number (lo word)	Unit Serial Number (32 bit integer lo word)					55	37
S80 Fault Status		1	16 bit Integer	R		56	38
S80 Sensor Type	Specific S80 sensor type (see S80 Sensor Types tab)	1	16 bit Integer	R		57	39
S80 Sensor Chemical Type	Specific chemicals the S80 is set to detect (see S80 Sensor Types tab)	1	16 bit Integer	RW	Y	58	3A
S80 Max Range (hi word)	Max sensor range (bytes 3 and 2)	2	32 bit Floating Point	R		59	3B
S80 Max Range (lo word)	Max sensor range (bytes 1 and 0)					60	3C
S80 Min Range (hi word)	Min sensor range (bytes 3 and 2)	2	32 bit Floating Point	R		61	3D
S80 Min Range (lo word)	Min sensor range (bytes 1 and 0)					62	3E
S80 Sensor Value (hi word)	Current sensor value (bytes 3 and 2)	2	32 bit Floating Point	R		63	3F
S80 Sensor Value (lo word)	Current sensor value (bytes 1 and 0)					64	40
S80 Sensor Voltage (hi word)	Corresponding sensor voltage to the sensor value (byte 3 and byte 2)	2	32 bit Floating Point	R		65	41
S80 Sensor Voltage (lo word)	Corresponding sensor voltage to the sensor value (byte 1 and byte 0)					66	42
S80 Sensor Temperature (hi word)	Sensor Temperature (bytes 3 and 2)	2	32 bit Floating Point	R		67	43
S80 Sensor Temperature (lo word)	Sensor Temperature (bytes 1 and 0)					68	44
S80 Sensor is a Sentinel	Sensor is a Sentinel Type (0 - No, 1 - Yes)	1	16 bit Integer	R		69	45
S80 Sentinel Life %	% of Sensor life remaining	1	16 bit Integer	R		70	46
S80 Sentinel Vs (hi word)	Scaled Sentinel Voltage (in mV) normalized to Vo (bytes 3 and 2)	2	32 bit Floating Point	R		71	47
S80 Sentinel Vs (lo word)	Scaled Sentinel Voltage (in mV) normalized to Vo (bytes 1 and 0)					72	48
S80 Sentinel Vo (hi word)	Sentinel 100% value (in mV) on the life relative to 0V (bytes 3 and 2)	2	32 bit Floating Point	RW	Y	73	49
S80 Sentinel Vo (lo word)	Sentinel 100% value (in mV) on the life relative to 0V (bytes 1 and 0)					74	4A
S80 Sentinel Range (hi word)	Sentinel Range (bytes 3 and 2)	2	32 bit Floating Point	RW	Y	75	4B
S80 Sentinel Range (lo word)	Sentinel Range (bytes 1 and 0)					76	4C
Sensor Full Name (18 characters max)	ASCII character bytes 0 and 1, ex. "AB" A - 65 (41 hexadecimal), B - 66 (42 hex), send 6566 (4142 hex). The characters permitted are space ' ' (32 base 10, 20 hex) through '}' 125 base 10, 7D hex).	1	16 bit Integer	RW	Y	77	4D
Sensor Full Name	ASCII bytes 2 and 3	1	16 bit Integer	RW	Y	78	4E
Sensor Full Name	ASCII bytes 4 and 5	1	16 bit Integer	RW	Y	79	4F
Sensor Full Name	ASCII bytes 6 and 7	1	16 bit Integer	RW	Y	80	50
Sensor Full Name	ASCII bytes 8 and 9	1	16 bit Integer	RW	Y	81	51
Sensor Full Name	ASCII bytes 10 and 11	1	16 bit Integer	RW	Y	82	52
Sensor Full Name	ASCII bytes 12 and 13	1	16 bit Integer	RW	Y	83	53
Sensor Full Name	ASCII bytes 14 and 15	1	16 bit Integer	RW	Y	84	54
Sensor Full Name	ASCII bytes 16 and 17	1	16 bit Integer	RW	Y	85	
Sensor Abbreviated Name (8 characters max)	ASCII character bytes 0 and 1, ex. "AB" A - 65 (41 hexadecimal), B - 66 (42 hex), send 6566 (4142 hex). The characters permitted are space ' ' (32 base 10, 20 hex) through '}' 125 base 10, 7D hex).	1	16 bit Integer	RW	Y	86	56
Sensor Abbreviated Name	ASCII bytes 2 and 3	1	16 bit Integer	RW	Y	87	57



Sensor Abbreviated Name	ASCII bytes 4 and 5	1	16 bit Integer	RW	Y	88	58
Sensor Abbreviated Name	ASCII bytes 6 and 7	1	16 bit Integer	RW	Y	89	59
Initiate S80 Storage	Signals the user has completed entering the data and wants it stored. Write any value.	1	16 bit Integer	W		90	5A
Cal log number to read	Cal log number to read (0 - Cal Log 1, 1 - Cal Log 2, 2 - Cal Log 3)	1	16 bit Integer	RW		91	5B
S80 Cal Log slope (hi word)	(bytes 3 and 2)	2	32 bit Floating Point	R		92	5C
S80 Cal Log slope (lo word)	(bytes 1 and 0)					93	5D
S80 Cal Log offset (hi word)	(bytes 3 and 2)	2	32 bit Floating Point	R		94	5E
S80 Cal Log offset (lo word)	(bytes 1 and 0)					95	5F
S80 Cal Log offset Voltage (hi word)	(bytes 3 and 2)	2	32 bit Floating Point	R		96	60
S80 Cal Log offset Voltage (lo word)	(bytes 1 and 0)					97	61

### Fault Status

Bit #	Bit meaning
0	Memory Error, either a Program Flash, RAM or NVM RAM checksum error has occurred
1	Input Voltage Out Of Tolerance
2	The On Board +12V is Out of Tolerance
3	The On Board +3.3V is Out of Tolerance
4	The Transmitter has lost communication link with the Sensor
5	There is no Sensor connected
6	Sensor Calibration Failed
7	Relay 1 on-time expired
8	Relay 2 on-time expired
9	Relay 3 on-time expired
10	Sentinel Error (useable life has expired)
11	Sentinel Poisoned
12	Membrane Error
13	NU
14	NU
15	NU

### WARNING STATUS

Bit #	Bit meaning
0	The Sensor has changed from previously connect Sensor
1	Not Used (NU)
2	NU
3	NU
4	NU
5	NU
6	NU
7	NU
8	NU
9	NU
10	NU
11	NU
12	NU
13	NU
14	NU
15	NU

SENSOR TYPE

Data		Meaning		
Decimal	Hexadecimal	Chemical	Sensor Type	Measurement Units
0	0000	Unknown Chemical	None	None
1	0001	Ammonia	mV	ppm
2	0002	Ammonium	mV	ppm
3	0003	Bromide	mV	ppm
4	0004	Calcium	mV	ppm
5	0005	Chloride	mV	ppm
6	0006	Conductivity	Conductivity	S
7	0007	Cupric	mV	ppm
8	0008	Cyanide	mV	ppm
9	0009	DO	mV	ppm
10	000A	DO	mV	% saturation
11	000B	DO	mV	mg/L
12	000C	Fluoride	mV	ppm
13	000D	Hardness (CaCO <sub>3</sub> )	mV	ppm
14	000E	Nitrate	mV	ppm
15	000F	ORP	mV	mVa
16	0010	pH	mV	none
17	0011	Potassium	mV	ppm
18	0012	Resistivity	Conductivity	Ohm (W)
19	0013	Silver	mV	ppm
20	0014	Sodium	mV	ppm
21	0015	Sulfide	mV	ppm
22	0016	Turbidity	TR86	FNU
23	0017	Turbidity	TR86	NTU
24	0018	Turbidity	TR86	ppm
25	0019	Turbidity	TR86	mg/L
26	001A	Turbidity	TR86	% solid
27	001B	DO	DO82	ppm
28	001C	DO	DO82	% saturation
29	001D	DO	DO82	mg/L
30	001E	Calcium	mV	mg/L
31	001F	TDS	Conductivity	ppm
32	0020	Nitrite	mV	ppm
33	0021	TCA (max range)	TCA	mg/L
34	0022	TCA (min range)	TCA	mg/L
35	0023	FCA (max range)	TCA	mg/L
36	0024	FCA (min range)	FCA	mg/L
37	0025	FCA HR	FCA	mg/L
38	0026	Resistivity	Resistivity	ohm
39	0027	Conductivity	Conductivity	S
40	0028	PAA (mid range)	PAA	mg/L
41	0029	Lead	mV	mg/L
42	002A	Salinity	Conductivity	PSU
43	002B	Ozone (min range)	OZ	mg/L
44	002C	Ozone (max range)	OZ	mg/L
45	002D	HP (low range)	HP	mg/L

46	002E	HP (high range)	HP	mg/L
47	002F	HP (low percent)	HP	%
48	0030	HP (high percent)	HP	%
49	0031	Hardness	mV	Gr
50	0032	H2SO4 (low percent)	H2SO4	%
51	0033	H2SO4 (mid percent)	H2SO4	%
52	0037	H2SO4 (max percent)	H2SO4	%
53	0035	PAA (low range)	PAA	mg/L
54	0036	PAA (max range)	PAA	mg/L
55	0037	Nickel	mV	mg/L
56	0038	NaOH	Conductivity	%
57	0039	FCL (max range)	FCL	mg/L
58	003A	Cadmium	mV	mg/L
60	003B	NH4 as N	mV	mg/L
61	003C	CLO2 Low	mA	mg/L
62	003D	CLO2 High	mA	mg/L



1500 North Kellogg Drive • Anaheim, CA 92807 • +1-714-695-0051 • FAX +1-714-695-0057 • [ecdi.com](http://ecdi.com)