

AC10 Air Blast Spray Cleaner



ELECTRO-CHEMICAL DEVICES

AC10 Automatic Sensor Cleaning

- Removes Biofilms and Other Soft Coatings
- Use with pH, ORP, DO, ISE and Conductivity
- NEMA 4X Self Contained System
- T80 Transmitter or C22 Analyzer Controls
Cleaning Cycles
- Wall Mount or optional 2" Handrail Mount

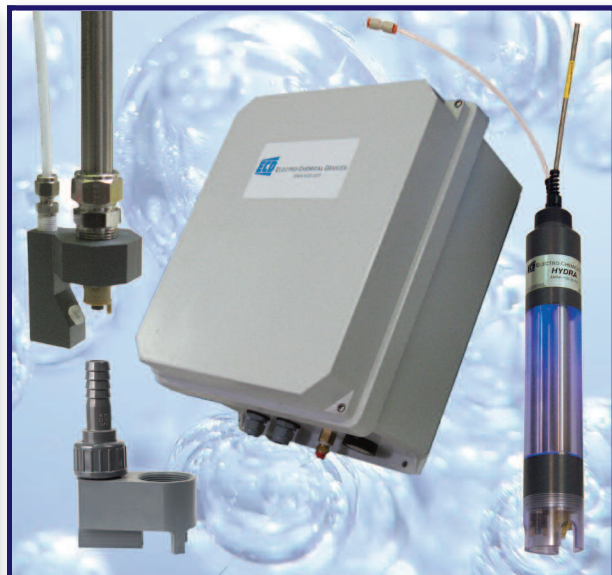

Description

The AC10 is a self contained, relay activated air compressor. The AC10 combined with a Sensor Spray Head and a C22 Analyzer/Controller uses pressurized air to generate an area of high turbulence in the water surrounding the measurement end of the sensor. The turbulence is suitable for removing biofilms and other soft coatings.

The AC10 can be a Single Channel or Dual Channel System. It is designed to be used with HYDRA Ammonium and Nitrate sensors, Triton® DO8 dissolved oxygen sensors or S10 style sensors for measuring pH, ORP, ISEs or Conductivity . Cleaning two sensors with the Dual Channel AC10 requires the C22 Analyzer/Controller be ordered with 4 Relays.

The AC10 uses redundant intake air filters and redundant fuses on both the relays and the compressor. A highly reliable high current contactor assures years of trouble free service. The 115 VAC 3.0 Amp or 220 VAC 1.3 Amp Air Compressor is

housed in a rugged, corrosion resistant, hot compression molded, fiberglass reinforced, polyester enclosure with a stainless steel piano hinge to secure the cover to the base. The AC10 can be wall mounted or use the optional 2" handrail mounting system that uses stainless steel support rails with two 2" galvanized pipe clamps.

The C22 Analyzer/Controller uses its internal Timers and Relays to control the Period and Duration of the cleaning cycles. The Period between cleaning cycles and the Duration of the cleaning are easily adjusted in the SET-UP menu of the C22. The 4-20 mA Outputs are placed in a "Hold Last Value" function during the cleaning cycle (Manual Mode-Bumpless setting).

Most cleaning operations can be accomplished with a 30 second cleaning every 15 - 30 minutes. When using the AC10 to clean stubborn coatings or two sensors keep in mind the maximum duty cycle for the AC10 is 10 minutes per hour, exceeding this value may cause the compressor to overheat.

AC10 Air Blast Spray Cleaner

Specifications

Description: Self Contained Relay Activated Air Compressor used for cleaning sensors configured with Air Blast Spray Cleaning Heads.

Enclosure: Fiberglass reinforced Polyester, NEMA 4X

Pressure: 40 psi, maximum(2.8 bar)

Flowrate: 1.24 CFM (35.1 LPM) 115 VAC
1.15 CFM (32.6 LPM) 220 VAC

Air Connection: ¼" Tube fitting

Duty Cycle: Less than 10 minutes per hour

Power: 115 VAC 60hz 5.5 A
220 VAC 50 hz 2.1 A

Fuses: Compressor 115VAC: (2) T.10A 250V, L & N
220VAC: (2) T.10A 250V, L & N
Controller Relay:(2) T. 0.5A 250V

Dimensions: 15.5"x 13.3"x 8.2"(39.4 x 33.7 x 20.7 cm)

Weight: AC10 wall mount: 20 lbs (9.1 kg)
AC10 Handrail Mount: 25 lbs (11.3 kg)

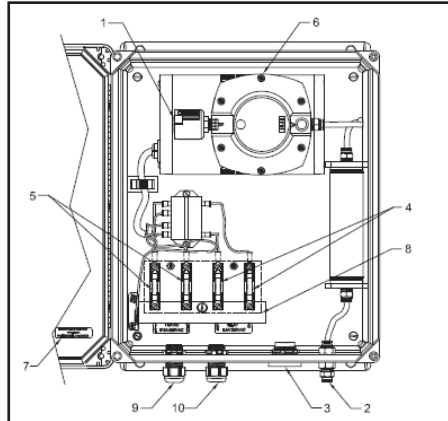
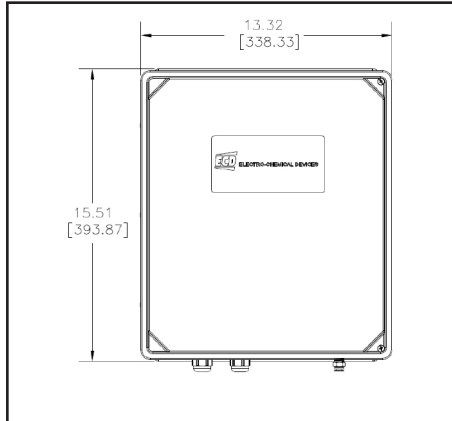

1. Air Filter, Interior
2. ¼" Quick Connect Tube Fitting
3. Air Filter, Exterior
4. Relay Fuses, T. 0.5A 250V
5. Compressor Fuses, T. 10A 250V
6. Air Compressor
7. Product Label, Part#, Serial#
8. Folding Protective Cover
9. Cable Gland, AC Power
10. Cable Gland, Control Signal

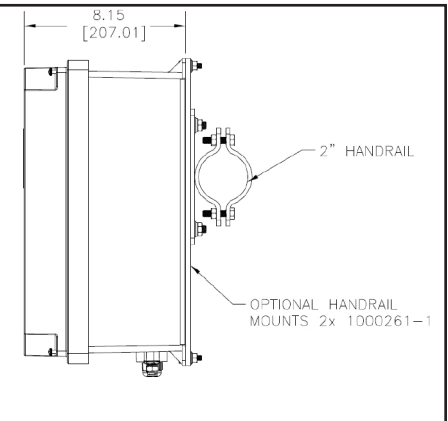
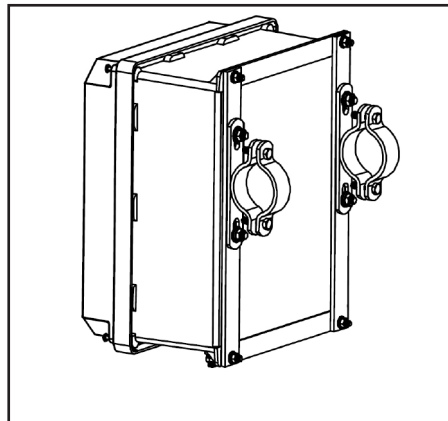
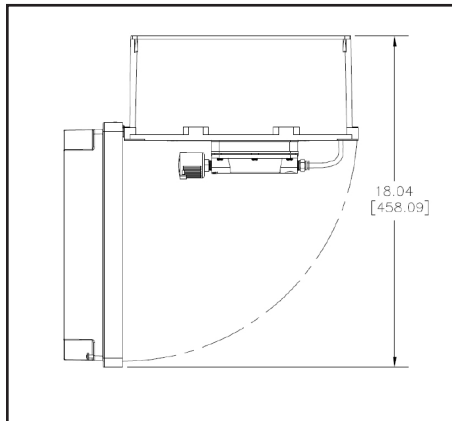

Part#	Description
1280100-1 (-5 Dual Ch)	AC10 Air Blast Cleaner, 115 VAC, Wall Mount
1280100-2 (-6 Dual Ch)	AC10 Air Blast Cleaner, 220 VAC, Wall Mount
1280100-3 (-7 Dual Ch)	AC10 Air Blast Cleaner, 115 VAC, Handrail Mount
1280100-4 (-8 Dual Ch)	AC10 Air Blast Cleaner, 220 VAC, Handrail Mount

Specifications subject to change without notice.

Represented by:

Electro-Chemical Devices

1500 North Kellogg Dr.
Anaheim, California, USA 92807

Phone: +1-714-695-0051

+1-800-729-1333

Fax: +1-714-695-0057

email: sales@ecdi.com

web: www.ecdi.com

